

# Optical Fiber Theory



for  
**Communication Networks**  
third edition

Stefan Gistvik



# Optical Fiber Theory

for

## Communication Networks

Stefan Nilsson-Gistvik



# Optical Fiber Theory for Communication Networks



**Stefan Gistvik**  
Fiberson AB

*This electronically stored book may be copied or printed  
for educational or private purposes only.  
Copying, retrieving, electronically storing this book for  
business purposes is prohibited under the copyright laws.*

© Copyright 2004  
Stefan Gistvik  
Sweden



# Foreword

---

This book is addressed to those who have a basic knowledge of conventional telecommunications technology, and who wish to learn the basics of fiberoptic telecommunications. The book deals with elementary optics, fiber manufacture, fiber parameters, cable technology, laser and light-emitting diodes, optical detectors, connectors and splicing techniques for optical networks, system theory, measurement techniques, installation of optical fiber cables and erbium doped fiber amplifiers.

The book contains mainly basic information that will not become obsolete.

The book is intended primarily for use as teaching material in supervised training courses. Each chapter may be read separately and the exercises at the end of the book should be done by each student as revision of the information covered in each section of the course. The book has been written so that it can be used for teaching at the upper secondary school or technical training college level.

I would like to thank all those, especially Ann Lidgard, Per Andersson, Torbjörn Carlнас, Bertil Arvidsson, Anders Björk and Peter Fickling who have contributed information and spent many nights checking the information in the text.

Hudiksvall, Sweden, 2006

Stefan Gistvik





## Table of contents

<b>Chapter 1, A look back in time and today</b> .....	1-1
Introduction .....	1-1
Antiquity .....	1-1
The 18th century .....	1-2
The 19th century .....	1-3
Alexander Graham Bell's "photophone" .....	1-3
The 20th century .....	1-4
The first attempts .....	1-5
The advantages of fiberoptics .....	1-6
What advantages does fiber optic technology offer over conventional technology? .....	1-6
Market picture .....	1-7
Yesterday vision of the future .....	1-8
<b>Chapter 2, Basic Optics</b> .....	2-1
Introduction .....	2-1
The electromagnetic spectrum .....	2-1
Geometrical optics .....	2-2
Reflection .....	2-3
Refraction .....	2-3
Refraction through a lens .....	2-4
Total reflection .....	2-5
Reflection of light at 90° angle of incidence Fresnel's laws of reflection .....	2-5
Polarized light .....	2-5
Total reflection in a fiber .....	2-7
Rayleigh scattering and Tyndall's light .....	2-7
<b>Chapter 3, Preform manufacture and fiber drawing</b> .....	3-1
Introduction .....	3-1
Production of silica glass through deposition .....	3-1
Preform production .....	3-3
Modified Chemical Vapor Deposition (MCVD) .....	3-3
Process description .....	3-3
Collapse of the preform .....	3-5
Outside Vapor Deposition (OVD) .....	3-6
Process description .....	3-6
Phase 1, deposition .....	3-6
Phase 2, the sintering process .....	3-6
Phase 3, fiber drawing. ....	3-7
Vapor-Phase Axial Deposition (VAD) .....	3-7
Production process .....	3-7
Fiber drawing .....	3-8
Proof test .....	3-10

<b>Chapter 4, Optical fibers and their parameters</b> .....	4-1
Modes	4-2
Normalized frequency and modes .....	4-3
LP <sub>01</sub> mode - the fundamental mode and cut-off .....	4-4
Numerical aperture .....	4-5
Numerical aperture for a fiber with graded index profile .....	4-6
Group refractive index .....	4-6
Mode field diameter .....	4-7
Effective area .....	4-7
Dispersion .....	4-8
Intermodal dispersion .....	4-8
Intramodal dispersion or chromatic dispersion .....	4-9
Polarization mode dispersion, PMD .....	4-10
Nonlinear effects .....	4-10
Multimode fiber with rectangular index profile .....	4-12
Multimode fiber with graded index profile .....	4-13
Standard single-mode fiber with rectangular index profile .....	4-14
Dispersion shifted fibers .....	4-15
Standard dispersion shifted fiber .....	4-15
Non-zero dispersion shifted fiber .....	4-16
Fiber with a continuous usable bandspectrum from 1285 nm to 1625 (1700) nm. ....	4-17
Dispersion-compensating fiber .....	4-18
Summary .....	4-19

<b>Chapter 5, How to choose the right optical fiber cable</b> .....	5-1
Introduction .....	5-1
Many parameters .....	5-2
First parameter, the optical fiber .....	5-2
Primary coating .....	5-3
Acrylate as the primary coating .....	5-3
Silicon as the primary coating .....	5-4
The fiber characteristics after primary coating application .....	5-4
Color-coding for optical fibers .....	5-4
Recommendations for optical fiber .....	5-5
Second parameter, the buffers .....	5-5
Loose tube buffer (loose fibers/ribbons in tube) .....	5-5
Temperature variations .....	5-6
Areas of application for loose tube buffered fibers .....	5-7
Tight buffered fibers .....	5-7
Areas of application for tight buffered fibers .....	5-7
Fiber ribbon technique .....	5-8
Encapsulating .....	5-8
Edge bonding .....	5-8
Encapsulated ribbon fiber .....	5-9
Manufacture .....	5-9
Color code for ribbons .....	5-9
Tests .....	5-9
Macrobend test .....	5-10
Torsion test .....	5-10
Crush test .....	5-10
Environmental test - temperature cycling, heat and humidity .....	5-10
Compatibility with filling compound .....	5-11
Reliability testing .....	5-11
Process testing .....	5-11
Strippability - random testing .....	5-11
Separability - random testing .....	5-11
Fiber curl .....	5-12

Attenuation .....	5-12
Geometry .....	5-13
Summary of fiber ribbon technology .....	5-13
Third parameter, the strength member .....	5-14
Metallic strength member .....	5-14
Central non-metallic strength member .....	5-14
Aramide yarn .....	5-14
Fourth parameter, the cable core .....	5-15
Cables with circular core .....	5-15
Cable with slotted core .....	5-16
Manufacture .....	5-16
Pitch of a slotted core cable .....	5-17
Expansion and contraction of cables .....	5-18
Expansion and contraction caused by temperature variations .....	5-19
Optical fiber cable without a core .....	5-21
Fifth parameter, the water protection .....	5-21
Filling compound .....	5-21
Water swelling tape .....	5-22
Metallic foil .....	5-22
Metallic tube, Copper encapsulation .....	5-22
Note .....	5-23
Sixth parameter, sheathing .....	5-23
Applying the final sheath .....	5-23
Polyethylene (PE) .....	5-24
Halogen-free, flame-retardant materials (HFFR) .....	5-24
Polyvinylchloride (PVC) .....	5-25
Polyamide (PA, Nylon) .....	5-26
Polybutylene terephthalate (PBT) .....	5-27
Fluoroplastics (PTFE, FEP, E-TFE, E-CTFE) .....	5-27
Thermoplastic polyurethane elastomer .....	5-27
Seventh parameter, extra reinforcement .....	5-28
Corrugated steel tape .....	5-28
Steel wire, steel tape .....	5-29
HET - heat expandable tape .....	5-29
Aramide yarn .....	5-30
Suspension strands .....	5-30
Optical ground wire, OPGW .....	5-31
Hybrid cables, .....	5-31
A collection of newer types of cables .....	5-32
Summary .....	5-33

<b>Chapter 6, Lasers and light emitting diodes .....</b>	<b>6-1</b>
About laser diodes .....	6-3
Areas of application .....	6-4
Telecommunications .....	6-4
Digital storage (CD players) .....	6-4
The computer industry .....	6-4
Graphics industry .....	6-5
Manufacturing and construction industries .....	6-5
Basic theory of semiconductors .....	6-6
Bohr's model of the hydrogen atom .....	6-6
Light emitted from the hydrogen atom .....	6-7
Molecular spectra .....	6-8
Electrons in a solid .....	6-8
Valence band .....	6-9
The conduction band .....	6-9
Energy band diagram .....	6-9
Conductors .....	6-10

Insulators .....	6-10
Semiconductors .....	6-11
The structure of the silicon atom .....	6-12
Fermi level .....	6-13
How a laser functions .....	6-13
Absorption .....	6-14
Spontaneous emission .....	6-14
Stimulated emission .....	6-15
The design of a laser diode .....	6-15
p-n junction .....	6-15
Laser structures .....	6-17
A simple laser .....	6-17
The heterostructure laser .....	6-18
Coupling of the laser diode to the fiber .....	6-19
Fiber as a lens .....	6-19
Microlenses .....	6-20
Tapering .....	6-20
Cooling and protection of the laser diode .....	6-20
Light emitting diodes .....	6-21
The dual heterojunction LED .....	6-21
Different types of LED .....	6-22
Surface emitting Burrus LED .....	6-23
Edge emitting LED .....	6-23
The efficiency of the LED .....	6-24
Characteristics of lasers and LEDs .....	6-24
Output power .....	6-24
Radiation lobe .....	6-25
Spectral width of LDs and LEDs .....	6-25
Modulation .....	6-26
<b>Chapter 7, Optical detectors .....</b>	<b>7-1</b>
Introduction .....	7-1
Photodiode, p-n type .....	7-1
PIN diode .....	7-3
Avalanche photodiode .....	7-5
Parameters affecting the detection of a light pulse in fiber optic systems .....	7-7
Intensity of the light pulse .....	7-7
Distortion of the light pulse .....	7-7
Receiver sensitivity .....	7-7
Quantum efficiency ( $\eta$ ) .....	7-7
Responsivity .....	7-8
Coupling the fiber to the detector .....	7-8
Receiver noise .....	7-9
Thermal noise .....	7-9
Shot noise or quantum noise .....	7-10
Dark current .....	7-10
Integrated optical detector/amplifier .....	7-10
Bandwidth .....	7-11
Reverse voltage .....	7-11
Signal-to-noise ratio (SNR) and Bit Error Rate (BER) .....	7-11
Bit Error Rate (BER) .....	7-12
Summary .....	7-13

<b>Chapter 8, Optical fiber splicing</b> .....	8-1
Introduction .....	8-1
Splices and connectors .....	8-2
Requirements of splices and connectors .....	8-2
Losses in a fiber optic link .....	8-3
Fiber-related losses .....	8-3
Mode field difference .....	8-4
Different numeric apertures (NA) .....	8-4
Different cladding diameters .....	8-5
Non-circularity of core and cladding .....	8-5
Core/cladding non-concentricity .....	8-6
Losses related to connectors and splices .....	8-7
Radial misalignment .....	8-7
Longitudinal separation .....	8-8
Angular deviation .....	8-9
Vertex and vertex misalignment .....	8-9
Surface finish .....	8-10
Other causes of splice loss .....	8-10
Fiber cleaving .....	8-10
Fusion splicing of optical fiber .....	8-11
The fusion process .....	8-12
Fusion splicing of fiber ribbon .....	8-12
Electronic image analysis .....	8-13
Mechanical splices .....	8-14
V-block splice .....	8-14
Precision-drilled tubes .....	8-14
Three-rod splice .....	8-14
Fiber ribbon splices .....	8-15
Semipermanent splices .....	8-15
Connectors with cylindric ferrule .....	8-16
The cylindrical ferrule .....	8-16
LME connector .....	8-16
SMA connector .....	8-17
FC connector .....	8-17
FC/PC connector .....	8-17
SC connector .....	8-18
ST connector .....	8-19
FDDI connector .....	8-20
Conical ferrule .....	8-20
Expanded beam .....	8-20
Expanded beam connector or a connector for military field use .....	8-21
Connectors for fiber ribbon .....	8-21
MT connector .....	8-21
Summary .....	8-22
<b>Chapter 9, The fiber optic link and system dimensioning</b> .....	9-1
Introduction .....	9-1
Transmission media .....	9-1
Network topology .....	9-2
Requirements specifications for optical networks .....	9-3
Planning a fiber optic system .....	9-4
Transmitter .....	9-4
Receiver .....	9-5
System dimensioning: Power budget .....	9-5
Power budget calculation - Example 1 (simple case) .....	9-5
Example 2 (complex case) .....	9-6
Calculations .....	9-7

Summary of system dimensioning: Attenuation .....	9-9
System dimensioning: Bandwidth .....	9-10
Chromatic dispersion .....	9-10
Pulse broadening due to chromatic dispersion .....	9-10
Time delay and pulse broadening due to modal dispersion .....	9-13
Total pulse broadening due to dispersion in multimode fibers .....	9-13
Bandwidth in multimode fibers .....	9-13
Bandwidth in single-mode fibers .....	9-14
Fiber rise time .....	9-14
Rise time of the optical link (multimode system) .....	9-15
Summary .....	9-16

**Chapter 10, Optical fiber measuring instruments and testing in single-mode fiber networks** .....

10-1	10-1
Introduction .....	10-1
Optical fiber measuring instruments .....	10-1
Optical Time Domain Reflectometer (OTDR) .....	10-1
Usability .....	10-3
How the OTDR works .....	10-3
Different types of OTDR measurement .....	10-4
Distance measurement .....	10-4
Optical power loss - attenuation .....	10-5
Splice loss measurement .....	10-5
Getting the splice loss value .....	10-6
Remarks .....	10-6
Dead zone .....	10-6
Pulse width .....	10-6
Dynamic range .....	10-7
A few advices .....	10-7
Stabilized light source .....	10-8
Power meters and sensors .....	10-9
Handheld light sources and power meters .....	10-9
Measuring with a stabilized light source and power meter .....	10-10
Practical attenuation measurement .....	10-10
Measuring connector and splice loss .....	10-11
Test accessories .....	10-12
Testing an installation .....	10-12
Instances of testing .....	10-12
Delivery testing .....	10-12
Inspection after laying .....	10-13
Splice loss measurement .....	10-13
Verification of the complete installation .....	10-14
OTDR tests .....	10-14
Attenuation measurement .....	10-14
Fault tracing .....	10-14
Approximate localization .....	10-14
Pinpointing the fault .....	10-15
Final documentation .....	10-16
Maintenance testing .....	10-16
Summary .....	10-16

<b>Chapter 11, Installation of optical fiber cable</b> .....	11-1
Introduction .....	11-1
Direct buried cable .....	11-3
Supervision .....	11-3
Plowing .....	11-3
Digging .....	11-5
Warning tape .....	11-6
Installation in cable ducts .....	11-6
Subducts .....	11-6
Different methods for installing the cable into the duct .....	11-7
Traditional pulling .....	11-7
Pulling forces .....	11-9
Effect of bends in duct installation .....	11-10
Installing duct cable using compressed air or floating with water .....	11-11
Compressed air .....	11-11
Floating with water .....	11-12
Cables for duct installation .....	11-12
Precautionary protection of optical fiber cable in manholes .....	11-13
Installation of aerial optical fiber cable .....	11-13
Self-supporting aerial cable .....	11-14
Installation of aerial cable by lashing or wrapping .....	11-15
Laying of submarine cable .....	11-16
Planning .....	11-17
Cable and jointing equipment .....	11-17
Installation of access networks .....	11-18
Access network .....	11-18
Different types of access networks .....	11-18
Fiber to the home (FTTH), the all optical access network .....	11-18
Fiber to the desktop, FTTD .....	11-18
Fiber to the curb, FTTC .....	11-18
An all optical access network .....	11-19
Planning .....	11-19
Traditional indoor installation of an access network .....	11-20
Blown fiber installation technique, Ribbonet® .....	11-20
Microducts and installation of microducts .....	11-21
Installation of fiber ribbon by blowing .....	11-21
The access node .....	11-22
Installing opto-electronic equipment at the user site .....	11-22
Finally on access networks .....	11-23
Splicing and the splicing environment .....	11-24
Joint closures .....	11-26
A variety of joint closures .....	11-26
NCD 503 .....	11-26
NCD 504 .....	11-26
NCD 505 1004 .....	11-27
Line terminals and Optical Distribution Frames .....	11-28
LT, ODF and FDF .....	11-28
Summary .....	11-29

<b>Chapter 12, Rare-earth doped fiber amplifiers</b> .....	12-1
Introduction .....	12-1
Theory of operation .....	12-2
General .....	12-2
Key Parameters .....	12-4
Gain .....	12-4
Gain Bandwidth .....	12-4
Signal Output Power .....	12-4
Noise figure .....	12-5
Fabrication of erbium-doped fiber .....	12-6
Fabrication methods .....	12-6
Bulk methods .....	12-6
Solution doping .....	12-7
Vapor phase doping .....	12-7
Erbium fiber design .....	12-9
Geometrical design considerations .....	12-9
Choice of host material in the fiber .....	12-10
Various amplifier designs .....	12-11
Single-wavelength systems .....	12-11
Power amplifier .....	12-11
In-line amplifier .....	12-12
In-line amplifier without power feeding .....	12-12
Pre-amplifier .....	12-13
Multi-wavelength systems .....	12-13
Analog vs. digital systems .....	12-13
Applications and Outlook .....	12-13
Capability explosion .....	12-13
Transmission networks .....	12-14
Distributed networks .....	12-15
Other areas of application .....	12-15
<b>Chapter 13, Tables</b> .....	13-1
Physical properties .....	13-1
Physical properties, cont. ....	13-2
Structure of the letter code .....	13-3
Load performance for some aerial cable .....	13-4
Load performance of aerial cable cont. ....	13-5
Technical specifications, cable construction .....	13-6
Technical specifications, fiber .....	13-8
Drumtable .....	13-10
<b>Chapter 14, Exercises</b> .....	14-1
A look back in time .....	14-1
Basic optics .....	14-1
Preform manufacture and fiber drawing .....	14-2
Optical fiber and fiberoptic parameters .....	14-2
How to choose the right optical fiber cable .....	14-3
Laser and light emitting diodes for information systems .....	14-4
Optical detectors .....	14-5
Splicing of optical fibers .....	14-5
The fiberoptic link and system dimensioning .....	14-6
Fiberoptic measuring instruments and measurement in single-mode fiber networks .....	14-7
Installation of optical fiber cable .....	14-7



# Chapter 1

## A look back in time and today

### Introduction

Since ancient times, man has needed to communicate with others. Prehistoric man made sounds by beating hollow logs (which functioned as resonators) with heavy sticks to communicate messages to others. The sounds varied in intensity and frequency so as to convey a variety of messages, such as warnings, fear, etc. Later, when hollow logs were replaced with drums of different sizes and shapes, a greater variety of sound images and patterns could be produced, which in turn allowed more complicated messages to be transmitted such as war or peace, a good or bad hunt, etc.

Different kinds of wind instruments have been found in the excavations of prehistoric settlements. Reed pipes and pipes made of different types of horn were also used for the same purpose as drums and hollow logs beaten with sticks.

The first optical signals, smoke signals, have been used wherever civilization has sprung up. We generally associate smoke signals only with the North American Indians, but smoke signals were used by the Chinese, Egyptians, Assyrians and Greeks. To add further nuance to the messages, the smoke could be coloured by burning a variety of barks or other vegetable matter.

### Antiquity

The night has always provided an excellent opportunity for communication using light. In the earliest civilizations, various combinations of torches on high mountain peaks were used to communicate rapidly over considerable distances.

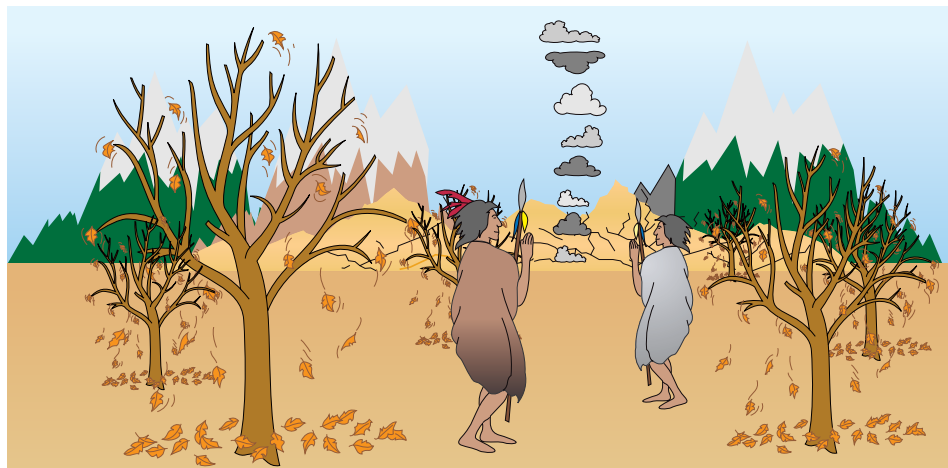

*Fig. 1-1 Probably the first optical communication was puffs of smoke from camp fires, which were given meaning by varying the size and space (period) between each puff.*

Legend has it that in 1185 BC, Queen Clytemnestra - via a series of signal fires - received the news that Troy had fallen, and that her husband King Agamemnon was on his way back to the palace in Argos. The distance was 800 km, covered by only nine signal fires. By the irony of fate, the first known optical communication was utilized for a murder. Getting the news so quickly, the Queen and her lover, Aegisthus, had plenty of time on their hands to plot the King's dispatch!

During the period of greatness of Ancient Greece, there were lighthouses along the coast of the Mediterranean. From Alexandria to Athens, messages could be sent by using torches in different combinations. Up to five torches were placed on the right side of the tower, and five on the left. In this way, the coordinates in a  $5 \times 5$  matrix system could be signaled and decoded as letters in the Greek alphabet.

Simple mirrors, such as shiny stones or pieces of glass, have also provided an excellent means of transmitting signals for centuries.



Fig. 1-2 An artist's impression of the lighthouse on the island of Pharos.

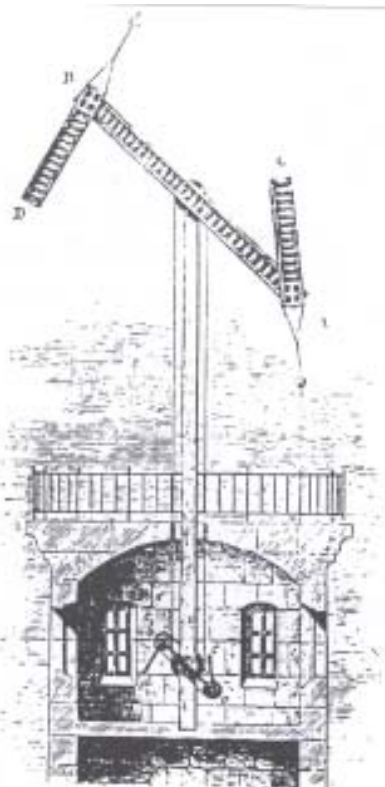

Fig. 1-3 One of the many towers that carried messages across long distances in western Europe.

## The 18th century

Leaping forward in time, we arrive at the end of the eighteenth century. A French doctor and inventor, Claude Chappe, had just developed the optical telegraph, and it had taken him over two years to do. The first test installation was built in Paris in the midst of the French Revolution. Unfortunately, his experiment was misinterpreted by the revolutionaries, who thought he was trying to make contact with the French king, Louis XVI, and his equipment was smashed to pieces. In 1793, he demonstrated his optical telegraph to the government and was engaged to build a link between Paris and Lille, a distance of 230 km. One year later, 15 stations had been built and on August 15, the government in Paris could receive the message that its forces had won a great victory at Le Quesnoy.

During the first half of the nineteenth century, many links were built between major cities and towns, primarily in France and Great Britain; 556 stations bridged a total distance of 5,000 km. Optical telegraphs were found long into the twentieth century, especially at isolated pilot and lighthouse stations.

## The 19th century

In the mid 1850s, the electric morse telegraph was invented, which eventually replaced the optical telegraph. This event was also more or less the beginning of the kind of modern communications world that we live in today.

During the 1870s, the English inventor Tyndall demonstrated that light could be made to travel through a bent water jet. The principle of optical transmission of information in light conductors had been established.



*Fig. 1-4 By demonstrating that light could travel along a bent water jet, the principle of optical transmission in light conductors was established.*

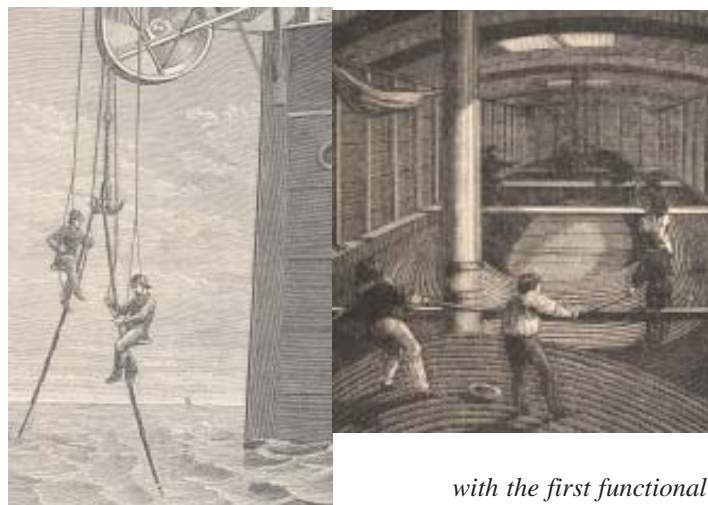
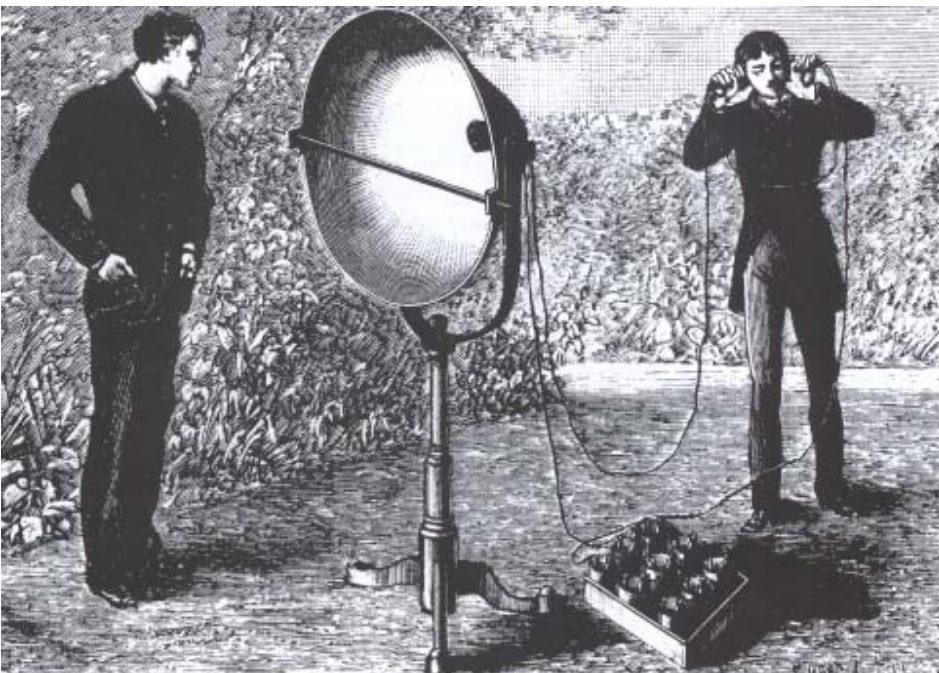
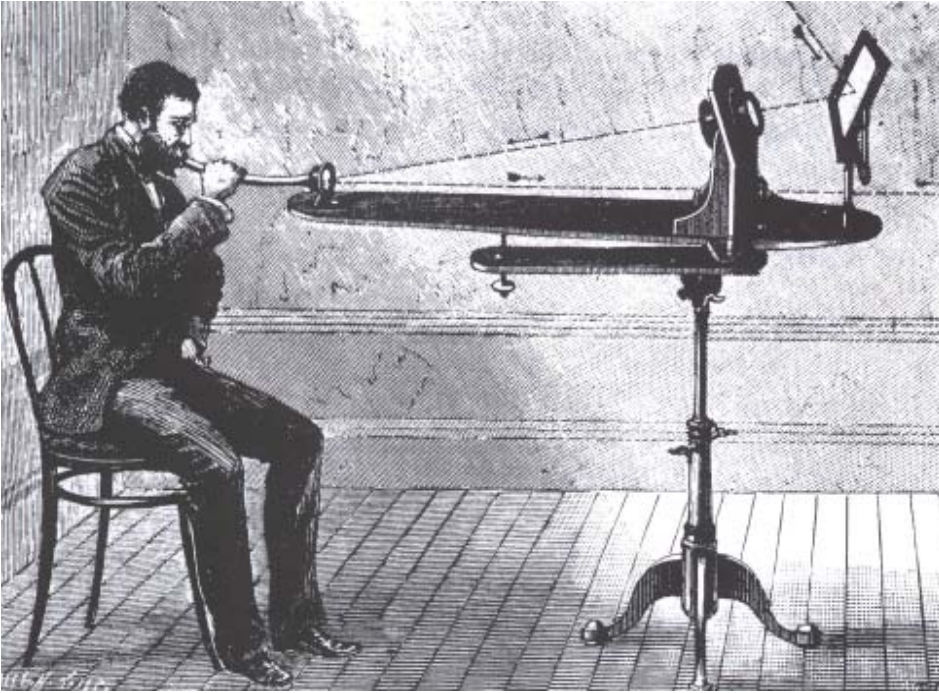

*Fig. 1-5 and 1-6 The capstan wheel of SS Great Eastern with the first functional Atlantic cable and the loading of the cable into the hold.*

## Alexander Graham Bell's "photophone"

Towards the end of the nineteenth century, Alexander Graham Bell was the first person to attempt the transmission of information in the modern sense using light. His invention, the photophone, utilized the modulation of sunlight to send a message to a receiver located 200 meters away. The sunlight reflected against a membrane vibrating with the sound of a human voice.

The modulated ray of light hit a selenium cell placed in the middle of a parabolic mirror. Earphones and batteries were attached to the selenium cell. The ray of light generated current fluctuations in the selenium cell and these fluctuations vibrated the membrane in the earphones, thus making the received signal audible.



*Fig. 1-7 and 1-8 Alexander Graham Bell and his collaborator at the photophone. Contemporary drawings.*

## The 20th century

In 1934, the American Norman R. French took out a patent for an optical telephone system. This system brought together Bell's and Tyndall's ideas. The patent described a system in which the voice was transmitted with the help of light in an optical cable network. The cables were to be made of solid glass with low attenuation at the frequencies used.

Twenty-five years later, technology had advanced sufficiently for the ideas presented in this patent to be realized. In 1964, the Nobel Prize was awarded to the

inventors of the laser. In 1962, the first types of semiconducting laser were produced. The prototype of the light source was now available and the only problem that remained was to produce an acceptable transmission medium.

## The first attempts

In an article published in 1966 in England, Charles H. Kao and George A. Hockham claimed that thin glass fiber could be used for information transfer. There was a minor problem, however: to be useable, the fiber would need to have an attenuation of less than 20 dB/km. In 1966, the lowest attenuation achieved in glass fiber was 1,000 dB/km! But in 1970, Corning Glass Works in the USA was successful in manufacturing a step index fiber with an attenuation of less than 20 dB/km at a wavelength of 633 nm.

Optical fiber with a graded index profile and an attenuation under 4 dB/km could be manufactured by 1972. Today, the attenuation of single-mode step index fiber is down to less than 0.22 dB/km for a wavelength of 1550 nm. Recent years have also seen a veritable avalanche of development in laser diodes, light-emitting diodes (LED), and photodiodes.

Optical fiber cables and splicing techniques for optical fiber cables have also undergone considerable development during the last ten years, so that now almost all of western Europe, Canada, Japan and the USA have complete national optical fiber networks.

In pace with technological development, there is a growing need to transfer larger and larger volumes of information. From the 1960s, this need has been growing almost exponentially, to a large extent thanks to computerization and the rise of the “information society”.

The first fiberoptic system was installed in the USA in 1977. Actual introduction of the technology began in the 1980s. The first applications were in metropolitan networks, to be followed later by introduction into the long-distance network. During the beginning of the 2000s, we will witness a huge explosion of fiberoptic technology in access and subscriber networks. Previously, technology has been the controlling and limiting factor in the introduction of fiberoptic systems; henceforth other factors will come to dominate: the market, costs and standards.



*Fig. 1-9 A modern fusion splicer from Ericsson. Normally, a fiber splice loss of less than 0.05 dB (average) can be expected.*

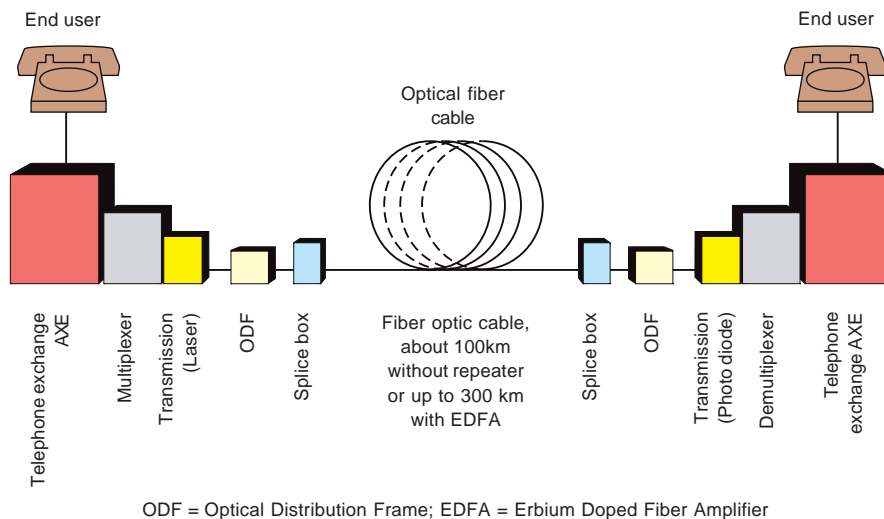

Fig. 1-10 The major parts of a fiberoptic communication system.

## The advantages of fiberoptics

But what exactly is a fiberoptic system? In its simplest form, it is a communications link in which optical fiber cables have replaced copper cables as the transmission medium. The information transferred by optical fiber is normally in digital form and transmitted by light pulses, not by electric current.

### What advantages does fiber optic technology offer over conventional technology?

- For telecommunications systems, the large distances over which information can be transferred between repeaters, around 100 km for optical fiber cable as compared to 2 km with electrical systems, and the large capacity of optical fiber, are the main advantages. With fiber optic amplifiers, (EDFA) the optical signal may be transmitted several hundred kilometers before an electrical regeneration is necessary. Amplifiers and receivers are steadily improving and the distance is thus increasing.
- For data communication and industrial applications, fibers immunity to interference, and its high integrity, are of greatest significance.
- Greater distances between repeaters are made possible thanks to fiber's low transmission loss. The optical fiber of today is the most transparent material that exists. Single-mode fiber has a typical, low attenuation of less than 0.25 dB/km (at 1550 nm wavelength) which, in percentage terms, means that even after 40 km, 10% of the light remains.
- Single-mode fiber has an enormous theoretical transmission capacity. System limitations are set more by the need for practicality and economy in the design of the electronics. For telecommunication, the standard is up to 2.5 Gbit/s for systems currently installed. 2.5 billion pulses per second means that close to 31,000 (64 kbit/s) telephone conversations can be transmitted simultaneously, or as digitized text, around 100,000 A4 size pages per second. The latter is equivalent to roughly the latest version of the Encyclopædia Britannica transferred via the telephone network in around one second! However, there is al-

ready talk of significantly increased speeds (5, 10 and 40 Gbit/s). Further increase of capacity is carried out by using, within the same fiber, transmission channels with different wavelength, **Dense Wavelength Division Multiplexing**. Systems with 8, 16 and 32 different wavelength are standard and systems with 200 different wavelength are tested in the laboratories (year 2001).

- The fiber in itself weighs almost nothing. To manufacture 100 km optical fiber only 2.7 kilogram of glass is needed. For fiber to be manageable, it must be protected inside a cable, but optical fiber cables are still much lighter than conventional copper cables.
- Glass fiber is an electrically non-conducting material and is thus not affected by electromagnetic interference from, for example, thunderstorms, heavy electric equipment, etc. Neither does the fiber give off its own interference field, and is thus not easily tapped and does not interfere with other machinery or equipment.
- Fiberoptic systems are generally much cheaper than conventional solutions, especially when any of the advantages described above is a significant factor. Modern telecommunication (or “infocom”) requires a broad bandwidth and high capacity over long distances. Fiberoptic communication has precisely these advantages, which was a contributing factor to fiberoptics being first used commercially in telecommunications.

In data communication and industrial applications fiberoptics have become important, even though bandwidth plays a less significant role.

## Market picture

Telecommunications also dominates the market picture of users of fiberoptic technology: over 60% in the USA and around 80% in Europe, although these figures are decreasing. The trend is for increased usage in data communication, and for increased short-distance usage in telecommunications, taking over from primarily long-distance usage.

Market development is to a large extent influenced by political factors. Telecommunications was previously a highly regulated market over the entire world, but during the 1980s, one after another of the state monopolies has been dissolved. The resulting free telecommunications market has created a large demand for telecom products. Where the USA, Western Europe, Southeast Asia and Japan have already gone down the path of deregulation, the rest of Europe will shortly follow.

Sweden has kept up well with developments, and is the first larger country in the world to have complete fiberoptic network coverage between all cities. All subscribers are connected to a modern AXE. Now by the year 2001, Sweden has close to 100 000 km of optical fiber cable, in other words, 50 times the length of Sweden, more than 5 million mobile telephones and 6 million fixed telephone lines, this within a population fewer than 9 million.

In many of the major cities in the world new companies are created and their only business concept is to supply optical fibers to all kinds of private customers, like chain stores, banks, power companies, hospitals or the local traffic companies.

The technology of optical fiber transmission has created a minor revolution in telecommunications, data and information transfer. The medium has an almost unlimited capacity, the basic material (sand) from which the fiber is made exists in virtually unlimited quantities, and semiconductor technology is as yet young and undergoing intense development.

There is one critical raw material, germanium, used to increase the refractive index in the fiber core. This material has been exposed to a substantial price increase over the last couple of years, probably due to the expansion of fiber optics. But since just a fraction of the fiber contains germanium, the price increase is less significant for single-mode fiber. There is expected to be a large growth in the demand for optical fiber in the future, see Fig 1-11.

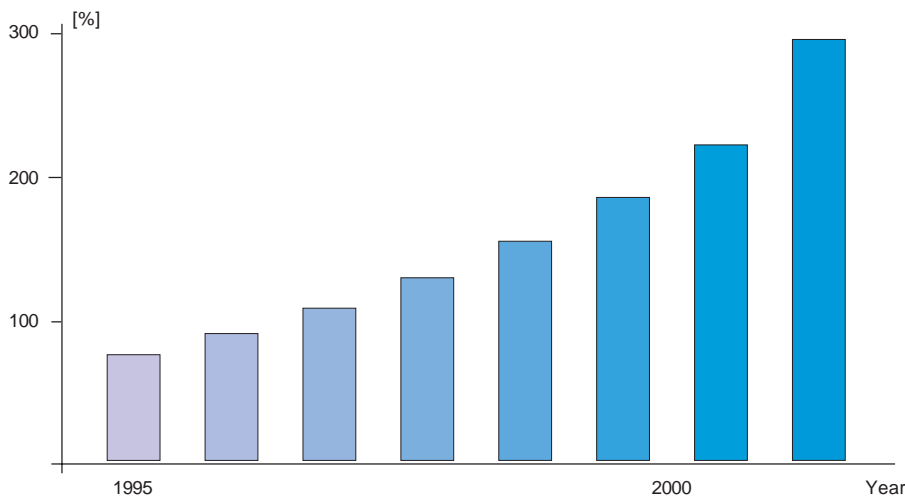

Fig. 1-11 Diagram showing the expected large growth in the demand for optical fiber.

## Yesterday vision of the future

This is what I wrote in the previous edition only six years ago: “Fiber-to-the-home (FTTH) represents an enormous potential for the introduction of a large number of broadband services. It is widely accepted that the subscriber network will develop very rapidly in the mid 1990s, with an increased need for capacity as a result of the introduction of new broadband services such as High Definition TV (HDTV), videophones, and data services; and the introduction of new technology for subscriber multiplexers and concentrators. It is likely that business customers’ needs will initiate this development”.

Now, six years later the future looks slightly different. The telecom networks have steadily become larger and more complex. The need for bandwidth is increasing with about 100 % per year. In many countries, all telecommunication between cities is carried by optical fiber cable, see Figure 1-12. Nevertheless the communication to each subscriber is yet carried by a twisted copper pair.

To reduce the need for the large copper cables with up to 2 400 twisted pairs in the premises network, part of the AXE can be removed and placed remotely from the exchange. These Remote Subscriber Stages, RSS, are connected to the AXE by optical fiber cable. This introduces fiber optic cable into the cities. Telephones



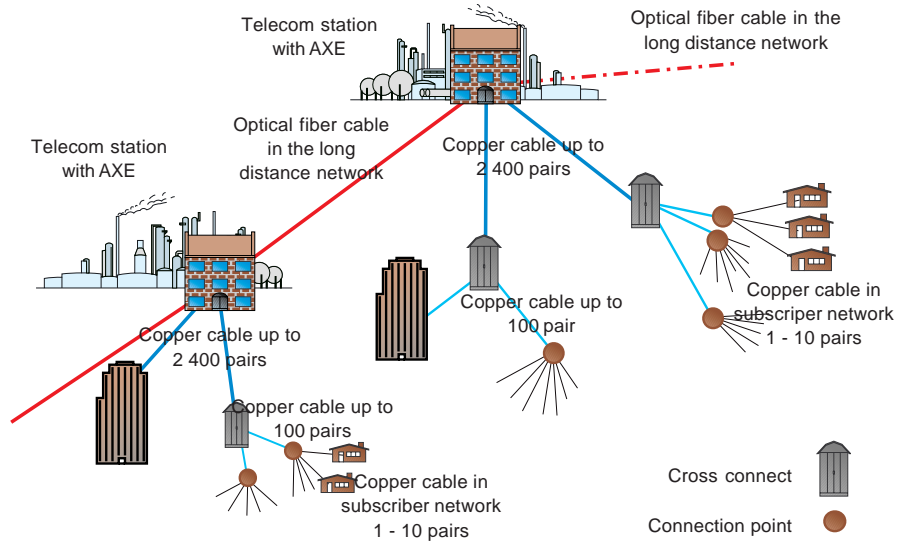

Fig 1-12. Traditional telecom network based on optical fiber cables between telecom stations and copper cables from station to subscriber.

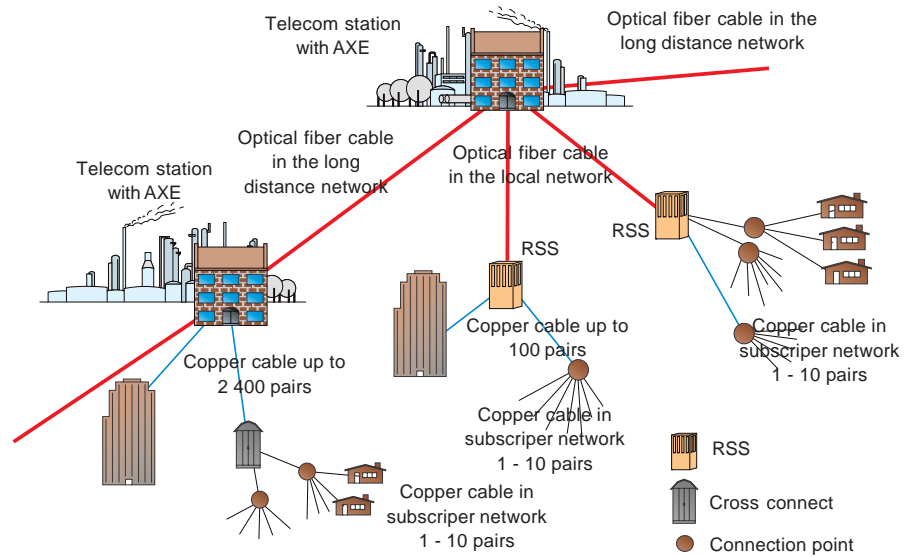

Fig 1-13. Parts of the copper based “heavier” local network is substituted with optical fiber cables and RSSes.

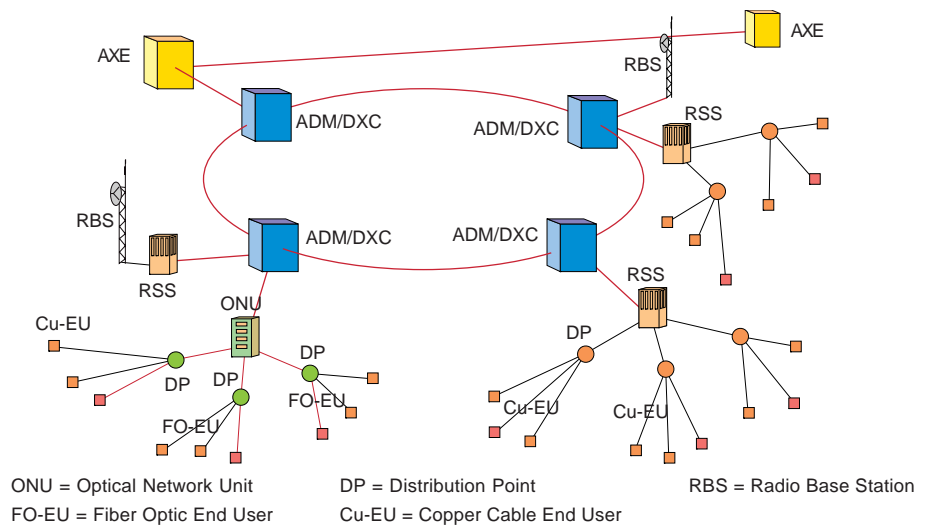

Fig 1-14. Optical fiber SDH ring with AXE, ADM/DXC, RSS och RBS

connected to the RSS will be able to make calls to other telephones connected to the same RSS even if the optical connection with the AXE is broken, thus increasing the availability of the network. RSSs can be interconnected forming rings of optical fiber cables in the cities, see Fig 1-13 and 1-14.

A new approach has been the introduction of optical fiber rings in the cities, for SDH (Synchronous Digital Hierarchy) and ATM (Asynchronous Transfer Mode). These “Core Feeder Networks” connects a number of ADM/DCCs (Add Drop Multiplexors/Digital Cross Connect) and/or Routers for high speed information within the ring and through an AXE if the information source is outside the ring, see figure 1-14 previous page.

Alongside the ordinary telecom networks, there are also networks being built by communities or by private investigators. During the fall of 1996, taking Sweden as an example, the power companies together with the different technical and administrative organizations within the community, plan or already have built optical fiber networks. These networks connect the different organizations with each other for internal telephone calls, e-mail, multimedia, and in the future video phone etc. These networks also connect all schools with each other so the pupils (and students) can use a common network for communication, data base search and Internet communication independantly of where they are in the schools. Hospitals and health care centers will share the same information and registers of patients can be stored in one safe place. Dispersed companies within the community will be able to share the same LAN for all units, thus giving them full control of their own communication and communication costs.

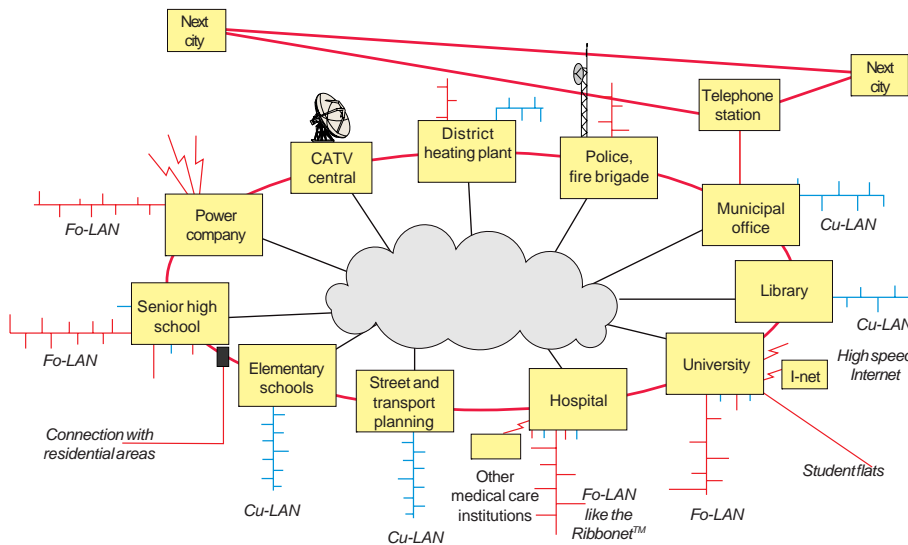

Fig 1-15. Sketchy drawing of an optical fiber community access network

The phenomenon Internet has in less than five years, become an important factor not only in the search of information, but for the larger manufacturers of telecom equipment (Ericsson, Alcatel, Motorola, NTT, etc), for telecom administrations (Telia, AT&T etc) and network owners it is creating large investments in new technology, network planning and building of networks. We have just witnessed the beginning of the Infocom era.

New ideas in designing a “future proof” network will be expressed in a book called “A guide on how to build fiber optic access networks - FTTX-netorks”.

# Chapter 2

## Basic Optics

### Introduction

Telecommunication technique using optical fiber introduces many new terms and concepts that will be new to telecommunications engineers. This chapter deals with basic concepts and terms in optics and, notably, fiberoptics.

### The electromagnetic spectrum

Light behaves in different ways under different circumstances. To describe light simply, a variety of approaches must be used. These are:

- Geometrical optics
- Wave optics
- Quantum optics

For our purposes, it is sufficient to consider light as an electromagnetic wave or as electromagnetic radiation. Light propagates in a wave in the same way as radio signals, radar, X-rays or gamma radiation. Light forms only a small part of the electromagnetic spectrum. Visible light lies within the wavelength range 390 – 760 nanometers ( $\text{nm} = 10^{-9} \text{ m}$ ) or 0.39 – 0.76 thousandths of a mm. Compare this to radio waves, with wavelengths of hundreds to thousands of meters! Light in general usage means only visible light, but the term is usually widened to include both ultraviolet (shortwave) and infrared (longwave) radiation.

In fact, the term light covers all radiation that may be managed in a similar way (with lenses, grids, prisms, etc). This wider range normally spans from 190 nm

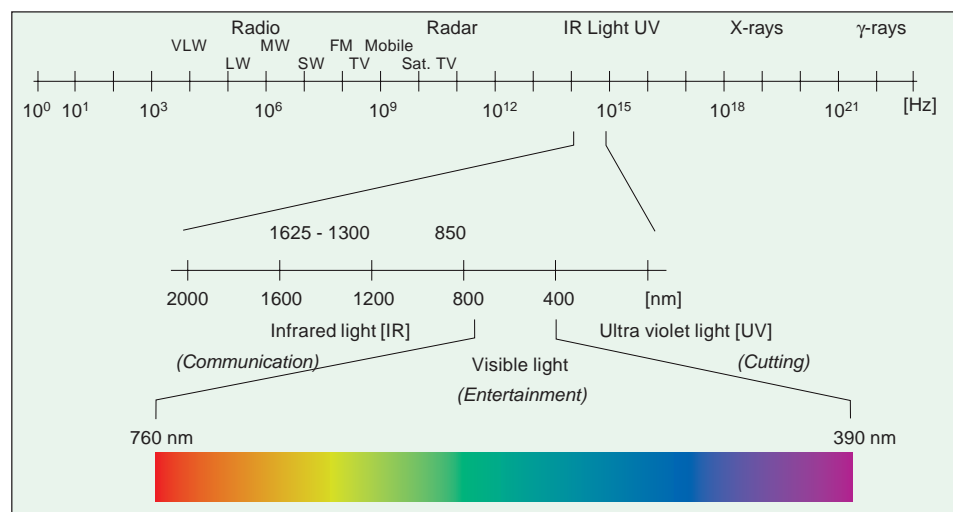

Fig. 2-1 The electromagnetic spectrum.

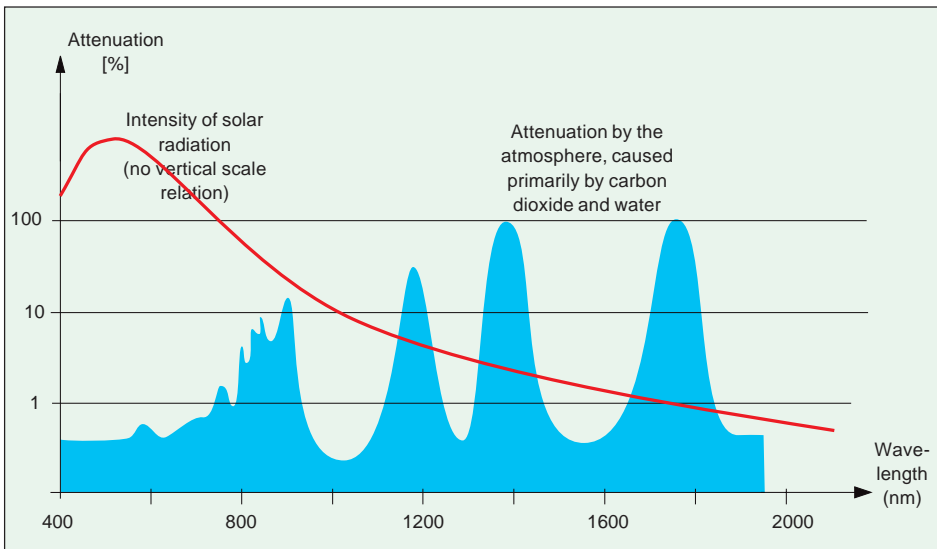

Fig. 2-2 The attenuation of solar radiation by the atmosphere for wavelengths visible to the naked human eye.

(UV light) to around 2,000 nm (infrared light). Life on earth is adapted to the transparency of the atmosphere, and there is a wavelength “window” in the atmosphere that coincides with the wavelength range of visible light, i.e., 390 – 760 nm, (Fig 2-2).

The transparency of the glass in fiber can be divided into five (six) windows (all with reduced attenuation of light) at around 850, 1310, 1390, 1550 and 1610 nm, respectively (and in the future maybe up to 1700 nm).

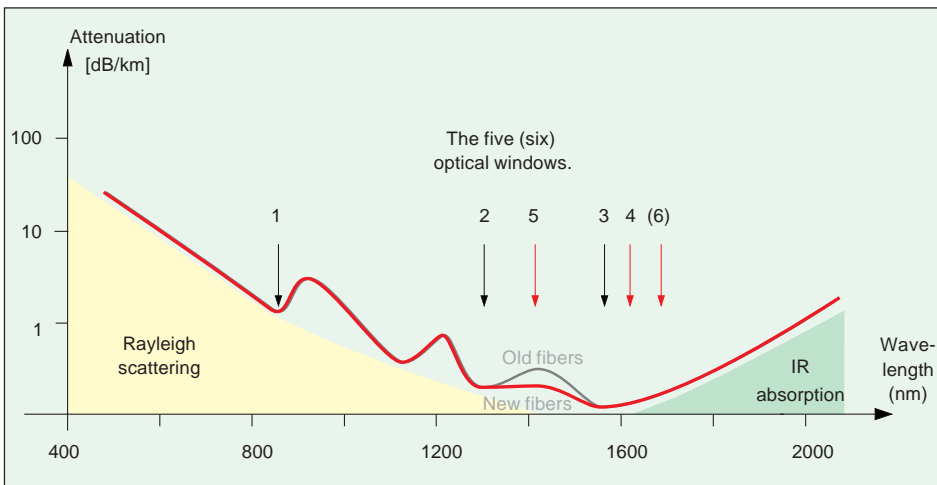

Fig. 2-3 The attenuation curve for optical fiber (glass). Note the five optical wavelength windows.

## Geometrical optics

Light has certain properties that can most simply be described by geometrical optics. However, many properties must be described by wave optics, and some properties can only be explained and described in terms of quantum mechanics (photons).

Geometrical optics has a history dating back two thousand years and assumes that light consists of rays that disperse from the source in straight lines (Fig 2-4) in an homogeneous environment, e.g., glass, water, air or a vacuum.

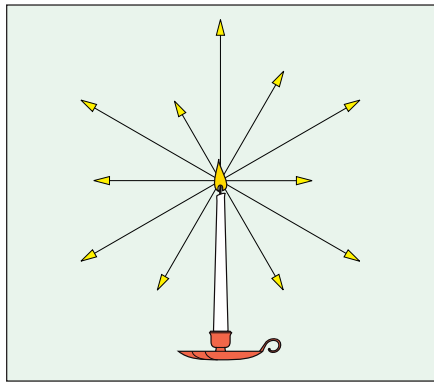

Fig. 2-4 Light disperses in straight lines from its source.

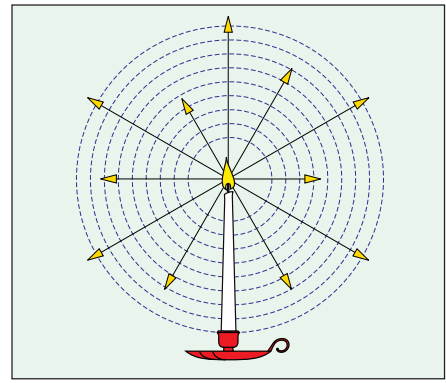

Fig. 2-5 Wavefronts are formed at right angles to the rays of light, and the light diminishes in proportion to the square of the distance.

It has further been assumed that plane wavefronts are propagated at right angles to each ray (Fig. 2-5). When a ray of light hits an interface between two media, it divides into a reflected ray (Fig. 2-6) and a refracted ray (Fig. 2-7). We have all seen mirror images not only in metal or glass mirrors, but even on a calm water surface, or in an ordinary glass window. We have also seen the visual effect that is created when an oar is dipped into water: the straight oar seems to be broken by the water surface.

### Reflection

A ray of light that is reflected by an interface reflects at the same angle to the normal as the angle of incidence to the surface.

Law of reflection:

Angle of incidence ( $i$ ) =

Angle of reflection ( $r$ )

$$i_n = r_n \quad \text{Formula 2-1}$$

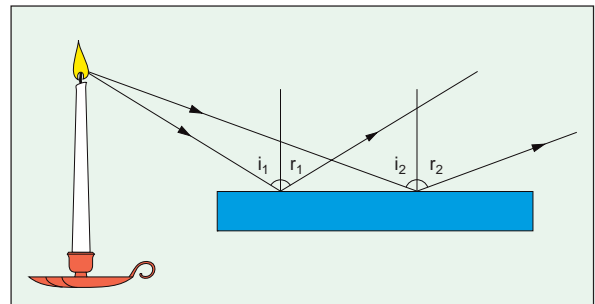

Fig. 2-6 Reflection on a plane surface.

### Refraction

The ray of light that is refracted forms a different angle to the normal than the angle of incidence. Refraction follows Snell's law, or the law of refraction:

Snell's law:

$$n_0 \sin \alpha = n_2 \sin \beta \quad \text{Formula 2-2}$$

where  $n_1$  and  $n_2$  are the refractive indices of the first medium and the second medium, respectively.

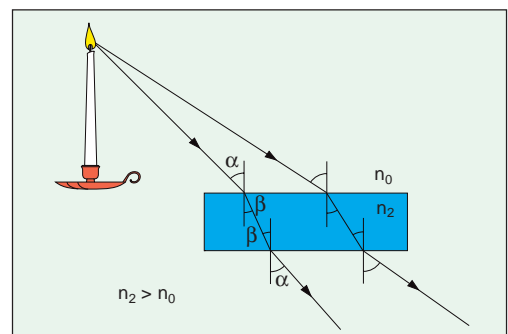

Fig. 2-7 Refraction of a light ray passing through an optically denser medium.

Generally, the indices of refraction (IOR or  $n$ ) for common media are given as:

Air (vacuum)	=	1
Water	=	1.33
Silica glass	=	1.444
Common glass	=	1.52

Light is refracted because the light will have a lower speed [ $v$ ] in a medium with a higher refractive index, which is described by the following formula:

$$v = \frac{c}{n_g} \Rightarrow n_g = \frac{c}{v} \Rightarrow n_g \geq 1 \quad \text{Formula 2-3a}$$

where  $c$  is the speed of light in a vacuum (299 792 458 m/s). The refractive index  $n_g$  varies with the wavelength  $\lambda$  as:

$$n_g = n - \lambda \frac{dn}{d\lambda} \quad \text{Formula 2-3b}$$

## Refraction through a lens

The most important application of geometrical optics is in the field of imaging technology (binoculars, cameras, etc) and particularly in the design of lenses and objectives. Lenses and curved mirrors have been used for over three hundred years and are the basic imaging elements. When rays of light from a point source hit a lens or curved mirror surface, the light rays will be reflected or refracted differently depending on the angle of incidence. Under the most favorable conditions, most of the light rays can be reconcentrated to a single point. If the light source is very distant and/or the light rays are parallel, light is concentrated at the focal point or focus ( $F$ ) of the lens or curved mirror. The distance from the central point of the lens to the focus is called the focal length ( $f$ ) (Fig. 2-8).

The following two formulas apply to imaging:

$$\frac{1}{a} + \frac{1}{b} = \frac{1}{f} \quad \text{Formula 2-4}$$

$$x \cdot y = f^2 \quad \text{Formula 2-5}$$

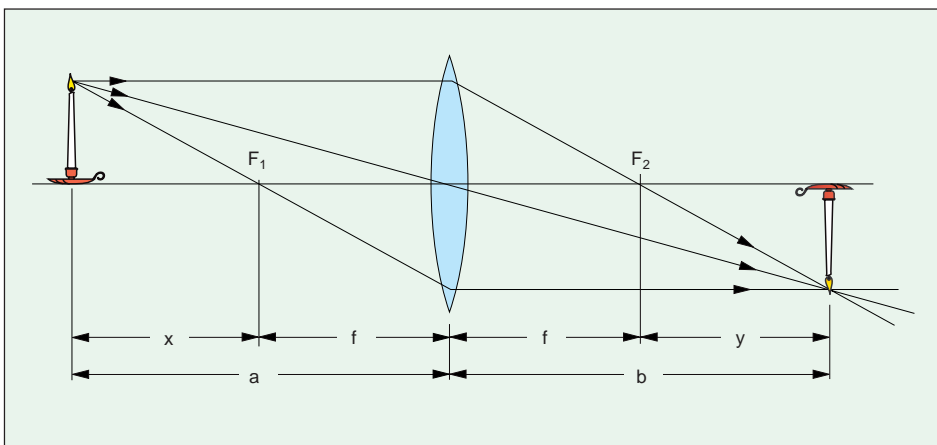

Fig. 2-8 The path, imaging and refraction of light through a biconvex lens.

## Total reflection

If light rays from an optically denser medium  $n_2$  hit an interface to an optically less dense medium  $n_1$  ( $n_2 > n_1$ ), and the angle of incidence is increased, the angle of refraction will approach  $90^\circ$ . If the angle of incidence exceeds the point where the angle of refraction is  $90^\circ$ , then a phenomenon known as total reflection occurs,  $\beta_T$ , i.e., when:

$$n_2 \sin\beta = n_1 \sin 90^\circ \Rightarrow$$

$$\sin\beta = \frac{n_1}{n_2}$$

Formula 2-6

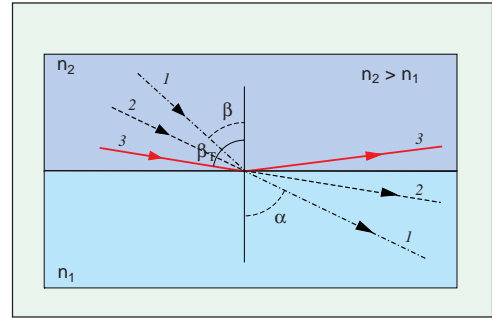

Fig. 2-9 When light travels from an optically denser to an optically less dense medium, and the angle of incidence exceeds a certain critical value, total reflection of the light occurs.

## Reflection of light at $90^\circ$ angle of incidence Fresnel's laws of reflection

Not even light that hits an interface at  $90^\circ$  can penetrate it fully; a small portion of light is always reflected. The reasons for this are as follows.

### Polarized light

Light can be considered as a wave that consists of two fields perpendicular to each other: an electrical field and a magnetic field (Fig. 2-10). In normal light, there is an infinite number of perpendicular oscillating planes propagating in the direction of travel of the light. By reflection and refraction, light can be polarized. Many people buy polarized sunglasses, for example, to reduce glare (reflection) from the sun off wet roads or the surface of the water when sailing. Light in which the electric field intensity remains unchanged while the magnetic field intensity

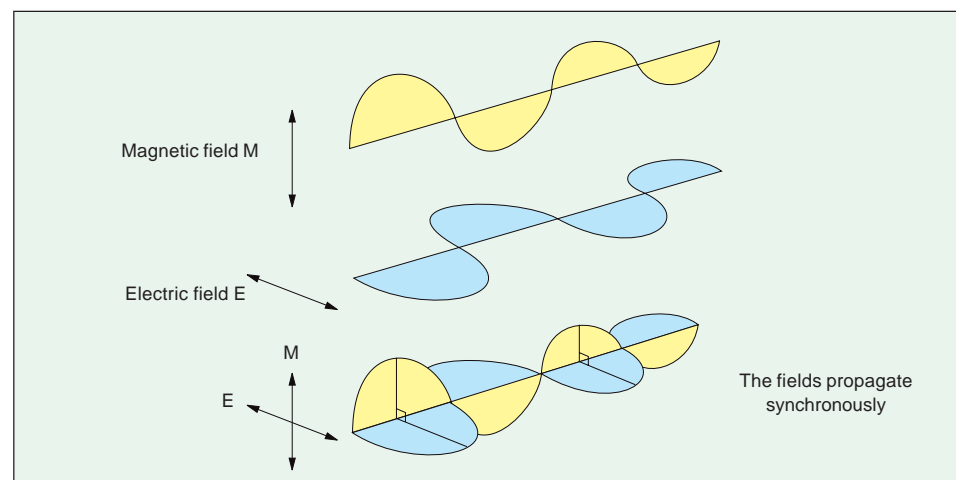

Fig. 2-10 Light consists of two fields: an electrical and a magnetic field. The two fields are synchronous with field vectors that maintain a  $90^\circ$  phase difference to one another.

decreases is termed TE-polarized light (transmittance of the polarized electric field). Light in which the magnetic field intensity remains unchanged while the electric field strength decreases is called TM-polarized light (transmittance of the polarized magnetic field) (Fig. 2-11 and 2-12).

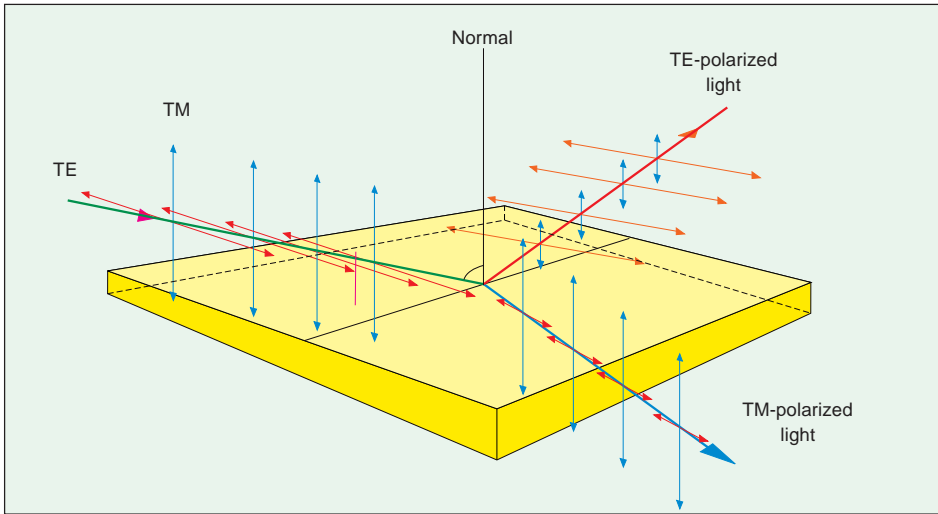

Fig. 2-11 Light hitting a surface will be polarized, and the electric and magnetic fields are polarized differently.

The two types of polarization have somewhat different reflection coefficients, which are described using Fresnel’s laws of reflection. The intensity of the reflected light increases from around 4 to 100% as the angle of incidence increases from 0 to 90° for both polarizations (the transmitted light decreases to the same degree), but for TM-polarization the intensity first decreases from 4% to zero before increasing again to 100% (Fig. 2-12). The angle at which TM-reflection is zero is called Brewster’s angle.

Reflectance  $R_0$  at 90° angle of incidence is given by Fresnel’s formula:

$$R_0 = \frac{(n_2 - n_1)^2}{(n_2 + n_1)^2} \quad \text{Formula 2-7}$$

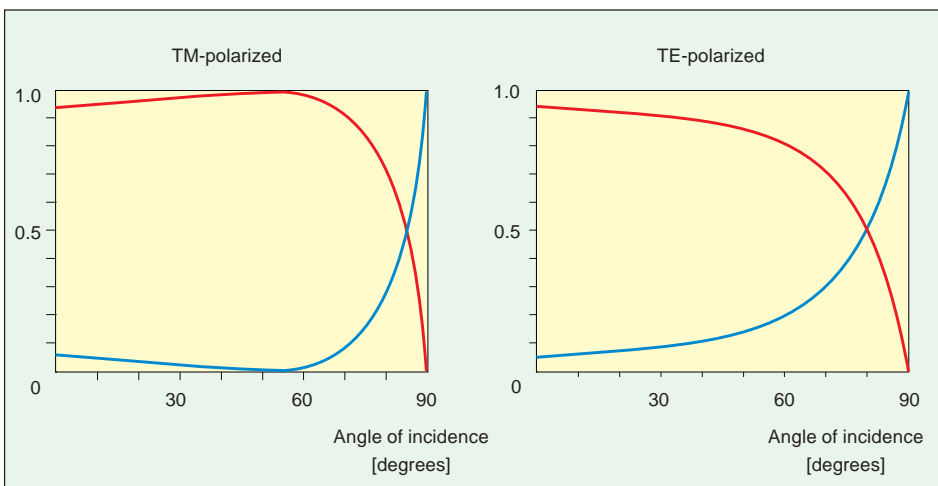

Fig. 2-12 Graphs showing the differences in reflectance of the different polarizations.



At other angles, the formula becomes more complex. For example, for quartz with a refractive index  $n = 1.46$ , the reflectance is approximately 3.5% to air, while for special glass with  $n = 1.81$ , the figure is 8.3%. From silicon, which is used as an optical material for IR light, the reflectance is 31% (because  $n = 3.5$ ). From vitreous silica to air, the critical angle is  $43.5^\circ$ .

## Total reflection in a fiber

Total reflection can easily be observed in a prism or in a transparent glass filled with water.

The principle of light propagation in an optical fiber is based on the principle of total reflection. In an optical fiber, there are two media (two different types of quartz glass) with a small difference in refractive index. Typical values are  $n_2 = 1.47$  and  $n_1 = 1.46$ , which gives a critical angle  $i = 83.3^\circ$  (Fig. 2-13). For light propagating in a fiber, the largest possible angle of incidence of light into the fiber

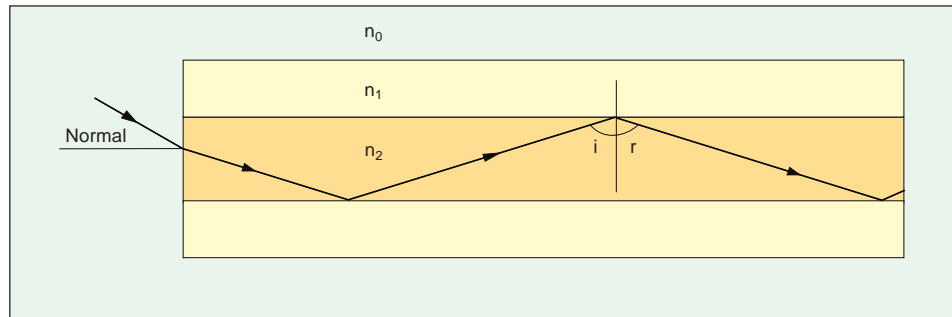

Fig. 2-13 The refraction of light entering the fiber, and total reflection within the fiber.

from the normal is considered. This is called the numerical aperture and is dealt with in the chapter entitled “Optical fiber and their parameters”.

We will later make a distinction between single-mode and multimode fiber. To properly describe single-mode fiber a treatment including the Maxwell equations is needed.

## Rayleigh scattering and Tyndall’s light

In an amorphous material such as glass, the density of the material is not exactly uniform throughout: there are bound to be local variations. The same applies to gases and liquids. An absolutely pure material cannot be manufactured either. Glass will never be completely transparent, i.e., it will be slightly turbid. A light

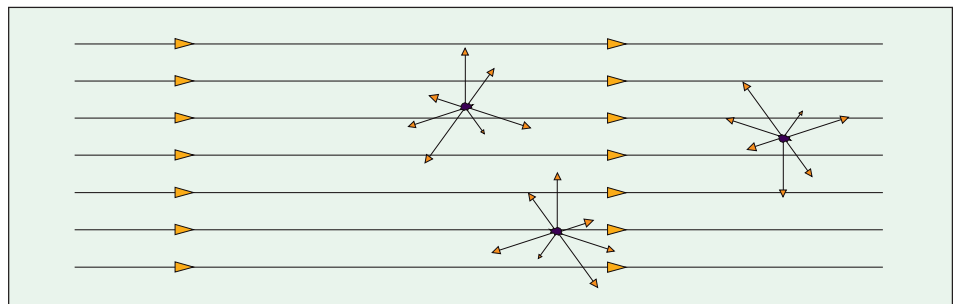

Fig. 2-14 Rayleigh scattering of light due to impurities in the light transmitting

ray travelling through such a material will be scattered in other directions (for example, a ray of sunlight in a dusty or smoke-filled room). This phenomenon, which is called Rayleigh scattering, is caused by the presence of small particles and inhomogeneities, which are hit by the light and scatter it in all directions. The light scattered is termed Tyndall's light. The hydroxyl group (OH<sup>-</sup>), metal ions, impurities etc account for this phenomenon in optical fiber.

Rayleigh scattering is what gives the sky its blue color, and the sun its red color at sunrise and sunset. These color phenomena are caused by the scattering of light by the molecules in the air.

The scattering of light (S) is proportional to the wavelength ( $\lambda$ ) according to:

$$S \propto \frac{1}{\lambda^4}$$

*Formula 2-8*

In the atmosphere, short wavelength light (the blue end of the spectrum) is scattered around 3 to 4 times more than long wavelength light (the red end of the spectrum), which gives the sky its color variations depending on the position of the sun in the sky. Lord Rayleigh explained this phenomenon at the turn of the century. Rayleigh scattering is of decisive significance in the choice of the wavelength range in fiberoptic communication. The longer the wavelength, the less Rayleigh scattering. Large particles such as dust scatter light at lesser angles (i.e., more or less straight ahead). If the particle is sufficiently large, it will function as a mirror and reflect the light directly back. A rainbow in the sky is an example of this.

The basics of light scattering in different types of optical fiber are dealt with separately in chapter 4, "Optical fibers and their parameters".

## Chapter 3

# Preform manufacture and fiber drawing

### Introduction

Just about 25 years ago, Corning Glass Works in the USA was able to successfully manufacture a glass fiber that had an attenuation lower than 16 dB/km. This was a major breakthrough in the manufacture of ultrapure glass and the attenuation value achieved was much lower than what had previously been achieved in manufactured glass. The Corning breakthrough was the beginning of worldwide, intensive research efforts, which would ultimately result in the fibers used today; fibers with a lowest attenuation close to the theoretically possible limit of 0.15 dB/km (in production about 0.18–0.21 dB/km).

### Production of silica glass through deposition

Optical waveguides for information transfer consist mainly of ultrapure silicon dioxide ( $\text{SiO}_2$ ). The core of the waveguide through which light is transmitted

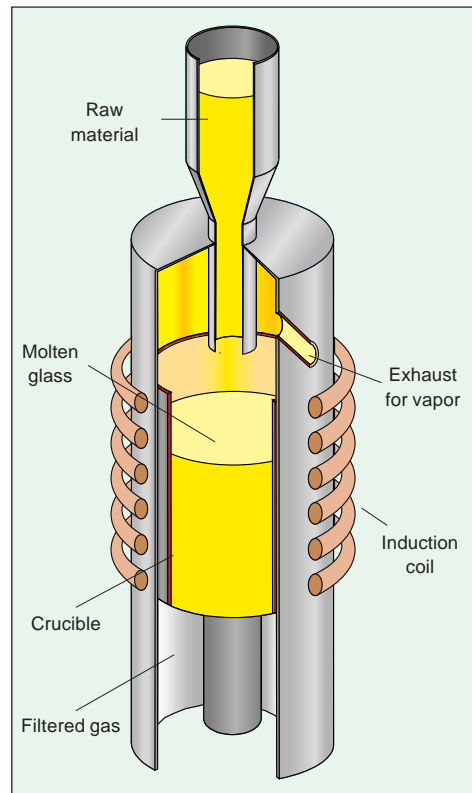

*Fig. 3-1 Melting of ultrapure glass with furnace heated by radio frequency (RF) induction.*

consists of silicon dioxide, usually doped with small amounts of germanium to increase the refractive index of the core, or with fluorine if the manufacturer wants to decrease the refractive index of the cladding. It is not only the silicon dioxide's low absorption of light that makes it the most suitable material to use in the manufacture of ultrapure, ultratransparent glass. Another factor is equally important: the industrial process used to produce ultrapure silicon dioxide, doped or undoped, is relatively simple. It is produced by the deposition of extremely pure, homogenized, silicon dioxide from  $\text{SiCl}_4$  in the vapor phase.

Natural silicon dioxide, e.g., quartz or quartz mineral sand, cannot be used directly for the production of fiber. Quartz and quartz mineral sand contain unacceptable amounts of metal oxides which must be removed.

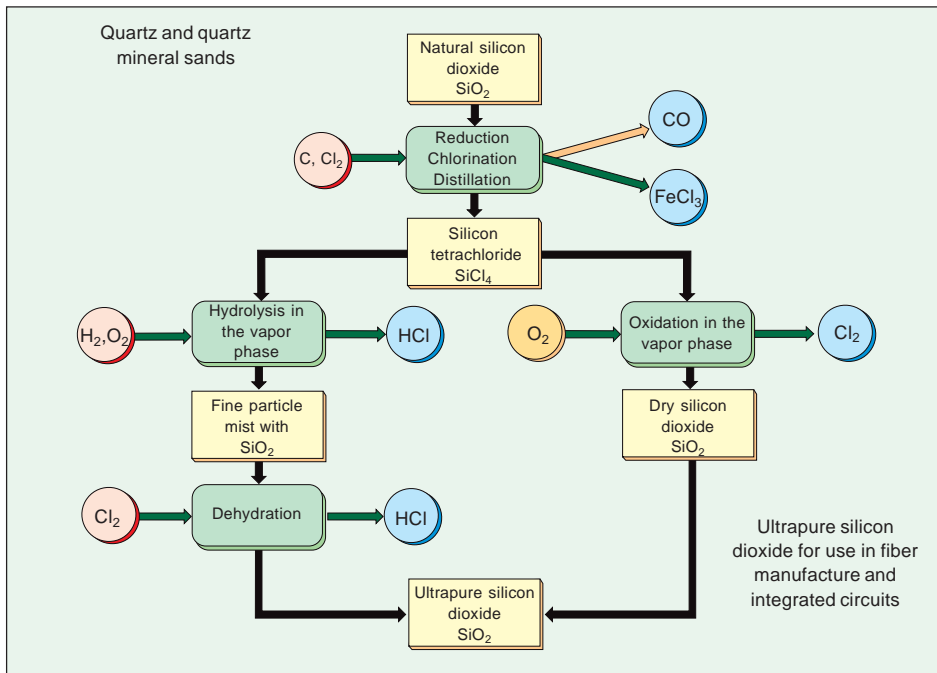

Fig. 3-2 Flowchart of the production of ultrapure silicon dioxide from natural quartz or quartz mineral sands.

Instead, liquid silicon tetrachloride (SiCl<sub>4</sub>) is vaporized. Silicon tetrachloride is produced from natural silicon dioxide by reduction with carbon and then reaction with chlorine. Fractional distillation guarantees that the silicon tetrachloride to be used is ultrapure. Metals in the form of metal chlorides, e.g. iron chloride, remain as waste products. Silicon tetrachloride also has other areas of application, e.g., in the production of ultrapure silicon as the basis for the production of semiconductors.

The next stage in the manufacture of glass for fiber is the recovery of silicon dioxide from the silicon tetrachloride. Silicon dioxide condenses out of the vapor phase, onto (or in) suitable substrates. Silicon tetrachloride can be doped by adding chlorides of primarily germanium (GeCl<sub>4</sub>) but sometimes also phosphorous (POCl<sub>3</sub>). The chloride or blend of chlorides is oxidized in a gas flame or in oxygen gas in a thermic reaction at around 1300°C. The reactions cause a very fine-particled powder of silicon dioxide to condense out of the vapor and coat the suitable substrate. The excess water (from the gas flame) in the silicon dioxide is effectively removed by the chlorine gas, since the water and chlorine react to form hydrochloric acid, which occurs at a temperature of around 1000°C. The removal of water (dehydration) contributes greatly to the transmission of light through the resulting glass fiber. The porous silicon dioxide is then sintered at temperatures exceeding 1200°C. The silicon dioxide forms a solid, bubble-free glass.

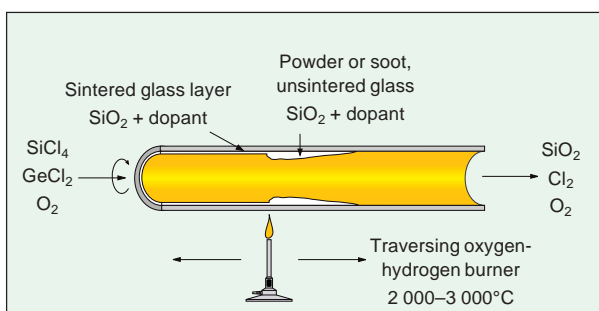

Fig. 3-3 Deposition of silicon dioxide at high temperature in an ultrapure quartz tube in the MCVD process (see next page).

The surface energy decreases in the porous silicon dioxide during the transition from particles to glass, providing the energy required for the consolidation process.

### Preform production

A variety of different methods for producing preforms has been developed in the years since the Corning Glass breakthrough. Here, the following methods are described:

- Modified Chemical Vapor Deposition (MCVD)
- Outside Vapor Deposition (OVD)
- Vapor-Phase Axial Deposition (VAD)

### Modified Chemical Vapor Deposition (MCVD)

The MCVD method for producing preforms for fiber manufacture was first described by MacChesney at AT&T Bell's laboratories in 1974. MCVD has become one of the most tried and tested methods used for manufacture of fiberoptic preforms. The process is simple, flexible and thus easy to emulate. Its simplicity has made the process suitable for basic research in the field of optical waveguides. Large-scale utilization of this method is practised at AT&T Technologies in the USA, and by many other manufacturers in the USA, Japan and Europe. The method permits the variation of a number of parameters, e.g., multimode or single-mode, the finished fiber diameter, numerical aperture (NA), and refractive index profile. These parameters are varied by varying the vapor flow of silicon dioxide and the doping substances, all controlled and supervised by computers. This makes it relatively easy for manufacturers to produce fibers according to a variety of requirements specifications.

#### Process description

MCVD involves the deposition of ultrapure silicon dioxide (always doped for the core) on the inside of a glass tube, then collapsing the tube by increasing the heat (gas flame or microwaves) so that the tube contracts into a solid glass rod of around 20–40 mm diameter and around 1,000 mm long. Today when the industry tries to make bigger and bigger preforms, one technique is to collapse a pure glass tube

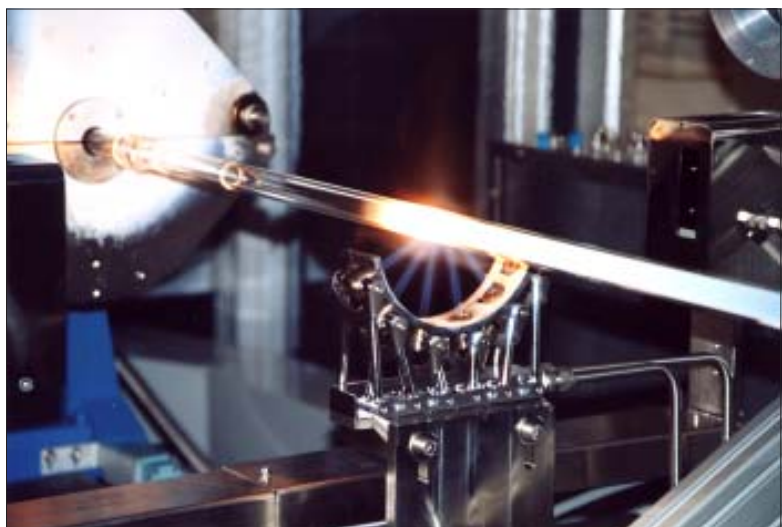

*Fig. 3-4  
MCVD-  
deposition at  
Acreo Fiber  
Lab  
in Hudiksvall  
Sweden*

on to the glass rod. In this way it is possible to create a larger preform to make the MCVD-process more efficient. The glass rod thus has the final fiber profile. This process also includes drawing the rod (called the preform) into a fiber that is suitable as an optical waveguide.

The deposition phase of the process is based on the high temperature oxidation of  $\text{SiCl}_4$  and also oxidation of the doping substances.

The process takes around four to eight hours, depending on preform size, during which time the glass that will be the inner cladding and the light conducting core is deposited. This deposition occurs in a similar way for both single-mode and multimode fibers. In conclusion it may be mentioned that, in 1974, when the first preforms were produced, the deposition speed was only some tenths of a gram per minute. Ten years later, the technique had been developed to the extent that the deposition speed was then a few grams per minute in production. In laboratories, with the help of microwave-plasma technology, deposition speeds of up to 15 g/min have been achieved.

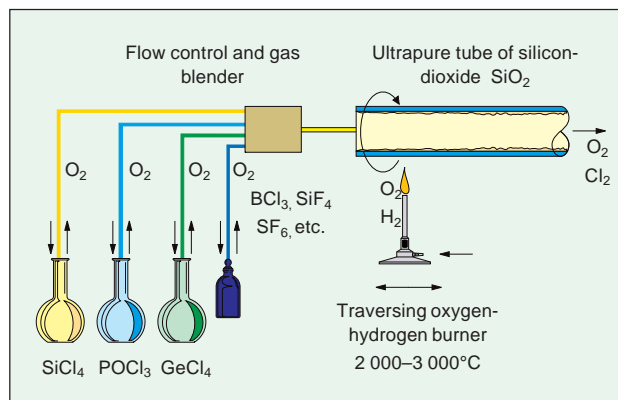

Fig. 3-5 The MCVD-process.

Germanium is the most commonly used core doping substance. Germanium increases the refractive index and is used to dope the silicon dioxide in the fiber light conducting core. Phosphorous oxide has been used to reduce the required process temperature and fluorine is used primarily to reduce the refractive index of the cladding. Normally a jacketing silica tube forms the major part of the fiber.

### Constituents of optical fiber

#### Multimode fiber

Core	Cladding
$\text{GeO}_2 - \text{SiO}_2$	$\text{SiO}_2$ $\text{F} - (\text{P}_2\text{O}_5) - \text{SiO}_2$

#### Single-mode fiber

Core	Cladding
$\text{GeO}_2 - \text{SiO}_2$	$\text{F} - (\text{P}_2\text{O}_5) - \text{SiO}_2$ $\text{SiO}_2$ $(\text{P}_2\text{O}_5) - \text{SiO}_2$ $\text{F} - \text{SiO}_2$
$\text{SiO}_2$	$\text{F} - (\text{P}_2\text{O}_5) - \text{SiO}_2$ $\text{F} - \text{SiO}_2$

The process begins when a very pure, high-quality silica glass tube is washed in an acid bath and then clamped in a lathe-like machine where the tube can be rotated around its central axis. An oxygen-hydrogen gas burner moves back and forth along the length of the tube to apply a strong but even heat to the tube. The inlet end of the tube is connected via a gas-tight rotating coupling to a chemical bubble system, which delivers the gases. This system includes the gas blender and computer regulated flow control (mass flow controllers). It is of the utmost importance that this part of the apparatus is absolutely leak-free, both to prevent

pollutants from entering the system and to ensure precise proportions of the various gases. At the other end of the tube, the outlet end, excess material is drawn out.

The process precisely controls the amount of the chemical constituents fed into the tube with the help of either bearer gases (Ar, He and O<sub>2</sub>), or as individual gas flows. In the hot zone created directly above the burner, SiCl<sub>4</sub> and the doping substances oxidize. The fine powder oxide formed is carried by the gas flow along the tube and deposited downstream. When the direct heat from the burner reaches the deposited powder, the heat melts the powder into a bubble-free, solid, transparent layer of silicon dioxide (doped or undoped). When the burner reaches the end of the tube, it reverses direction and moves quickly back along the tube to the starting point to deposit a new layer of powder. A variety of doping substances are introduced in varying amounts during the deposition phases, i.e., cladding deposition and core deposition. By successively depositing layer upon layer of doped silicon dioxide while varying the amount of doping substance/s, fiber with varying index profiles can be produced. Pollutants of all kinds are prevented from entering the system as far as technically possible - particularly pollutants containing hydrogen. Hydrogen forms OH<sup>-</sup> pollutants in fiber, and OH<sup>-</sup> results in serious increases in the attenuation in light waveguides.

The basic advantage of the MCVD process is that the waveguide structure and properties can be built into the preform and retained in the finished fiber. The relative dimensions and the index profile of the preform are transferred to the finished fiber during the drawing process.

### Collapse of the preform

After deposition is complete comes the next important stage of the preform manufacture: the collapse of the tube. This occurs in several steps. For the collapse, the heat is increased (oxygen-hydrogen gas burner or microwaves) to 1500–2000°C, a temperature at which the tube slowly softens and collapses to a solid preform rod. This process is decisive for the preform final geometric properties. The collapse occurs when the oxygen-hydrogen flame or microwaves pass successively along the tube. The mechanism behind the collapse is an inward viscous flow caused by the surface tension, which increases as the glass gets hotter and less viscous.

*Fig. 3-6 Intense heating causes the hollow preform to soften and collapse to a solid rod.*

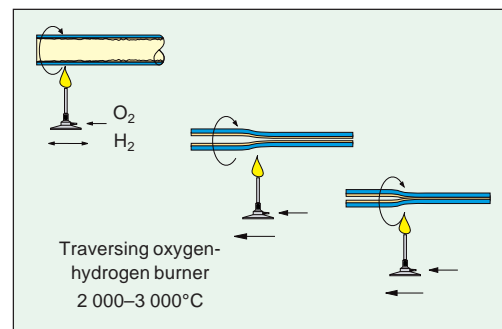

## Outside Vapor Deposition (OVD)

The description of this method will be much shorter than the preceding process description, since the basic chemical conditions are largely the same. Compared to MCVD, OVD is significantly more complex. Its complexity, and comprehensive patent protection, have meant that this process is used exclusively by Corning Glass Works (which developed the process) and their licensees. However, the total volume of OVD fiber produced today is probably as large or even larger than the volume of MCVD fiber. This is due to the fact that, in large-scale production, the OVD method is more efficient than the MCVD method. As mentioned earlier the MCVD-method has been improved to increase the efficiency.

### Process description

The OVD process is divided into three phases.

#### Phase 1, deposition

Phase 1 involves deposition of the silicon dioxide powder (often referred to as soot particles) with or without doping substances (see MCVD process description) onto a thin rod. A hot stream of soot particles passes over the surface of the rod, some of which adhere to the rod which, while rotating, moves axially past the burner. A porous preform is built up, layer after layer. Some of the particles will be in a sintered state. When a sufficient amount of glass for both the core and the cladding has been deposited, the process is stopped and the starting rod is carefully drawn out of the preform.

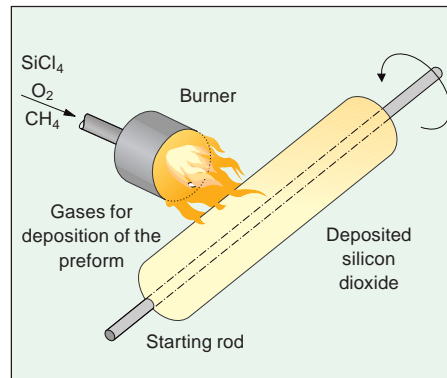

Fig. 3-7 The OVD method for making a preform.

#### Phase 2, the sintering process

The porous form is heated first in an atmosphere of chlorine gas, which removes water, and then heated further to a temperature of 1600–2 000°C, a temperature at which the soot particles sinter into a solid, bubble-free glass rod: the

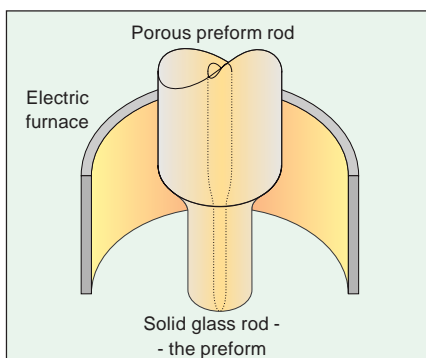

Fig. 3-8 The porous preform is collapsed into a solid glass rod.

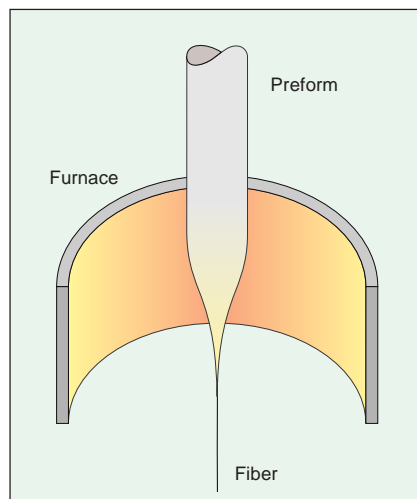

Fig. 3-9 Fiber drawing.



preform. This takes place in a controlled furnace atmosphere. The hollow from the starting rod generally collapses and fuses during this phase.

### **Phase 3, fiber drawing.**

The preform, with or without its hollow center, is heated to 1800–2300°C, at which point a fiber can be drawn from the preform.

To summarize, the OVD process involves five basic steps:

- Purification of materials
- Transport of reacting substances to the heat zone
- Chemical reactions and particle formation
- Particle deposition on a substrate (starting rod or already deposited preform)
- Dehydration and sintering.

## **Vapor-Phase Axial Deposition (VAD)**

The Vapor-Phase Axial Deposition (VAD) method was developed in Japan in order to circumvent patent infringement of Corning's OVD method, and to permit continuous manufacture of preforms for the production of fiber.

### **Production process**

The VAD method is similar to the OVD method insofar as deposition is external rather than internal, and a porous preform is formed which is then dehydrated and sintered. However, soot particles are deposited axially in this method, not radially as in the OVD method. This makes it more difficult to modify the index profile, but easier to make longer preforms. The manufacturing system consists of a mechanism for axial movement of the preform, reaction chamber, burner, vaporizing unit for the constituent raw material, and a control unit. The preform is drawn slowly, vertically, upwards through the manufacturing equipment. The raw materials ( $\text{SiCl}_4$ ,  $\text{GeCl}_4$  and  $\text{POCl}_3$ ) are injected in the same way as in the OVD method; an oxygen-hydrogen gas burner is used and extremely fine glass particles formed in flame-hydrolysis reactions are deposited on the end surface of an already deposited preform, which functions as a growth substrate. The porous preform grows axially and is moved axially at the rate of growth. The preform is dehydrated and consolidated into a transparent rod in an electrically heated ring-shaped graphite resistance furnace.

The important elements of the process are:

- A constant growth process
- Precise control over the flow of raw materials
- Precise control of the outflow of excess materials
- Flame temperature
- Surface temperature of the preform growth zone
- Rate of rotation of the preform
- Position of the preform growth zone.

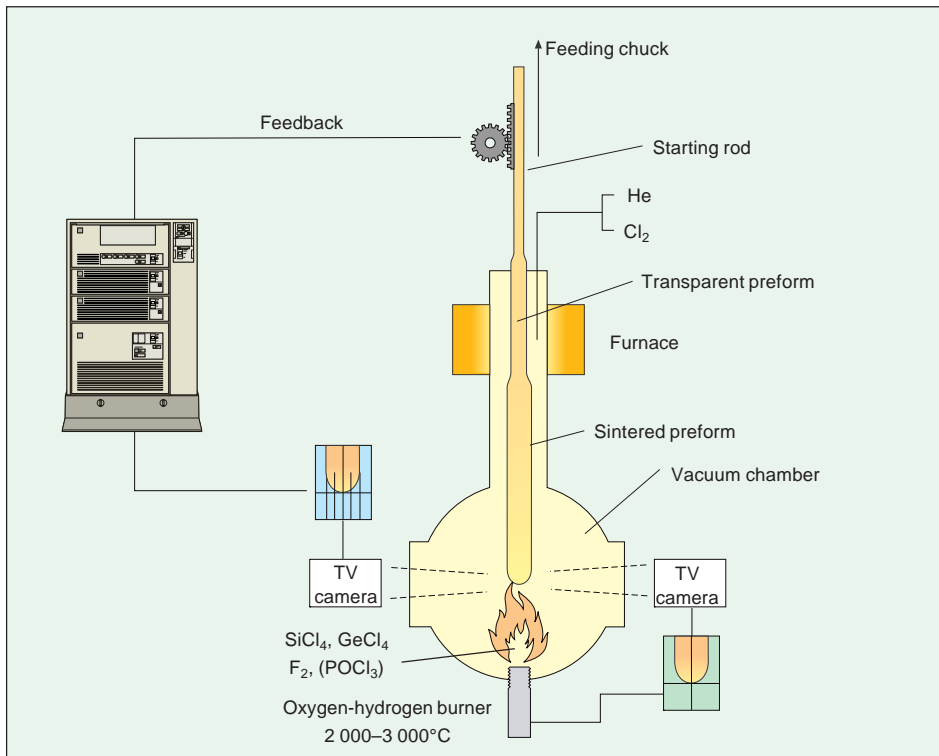

Fig. 3-10 Schematic diagram showing the VAD method of preform manufacture.

Variations in the position of the growth zone give fluctuations in the index profile of the finished preform. The axial speed (= rate of growth) is approximately 40–60 mm/hour.

One to three burners are used for deposition. Different index profiles can be obtained by varying the number of burners and the content and proportions of the raw materials. During consolidation, the preform is dehydrated in an atmosphere of chlorine gas. To obtain a thicker cladding, an additional deposition can be made on the surface of the sintered preform rod. This means that very large preforms can be produced.

## Fiber drawing

The finished preform rod, irrespective of the method used to manufacture it, is drawn into fiber in a drawing tower. The height of the tower is a function of drawing speed and cooling rate respectively, see text below. Today drawing towers heights vary between 10 to 30 m.

To illustrate the drawing process a general approach is given. It must be emphasized that several details can vary substantially. The drawing begins at the top of the tower, where the preform is clamped into a centering chuck.

The preform lower end is placed in an electrically heated furnace and heated to over 2000°C. The graphite heating element is protected by an inert atmosphere of argon gas. The preform is slowly inserted into the furnace from above at the same time as a fiber is drawn down and out of the furnace. The drawing speed and feeding speed are automatically supervised by a computer-based control system.

Immediately under the furnace, a laser-controlled measurement instrument checks the diameter of the fiber. The values obtained are fed back to the control system which controls the speed of the drawing capstan at the bottom of the tower. Increases in the fiber diameter result in increases in the drawing speed and vice-versa. Standard fiber has a diameter of  $125 \pm 1 \mu\text{m}$ . This is a sign of the high quality of the fiber available today. As mentioned above, the drawing speed and cooling rate are important factors.

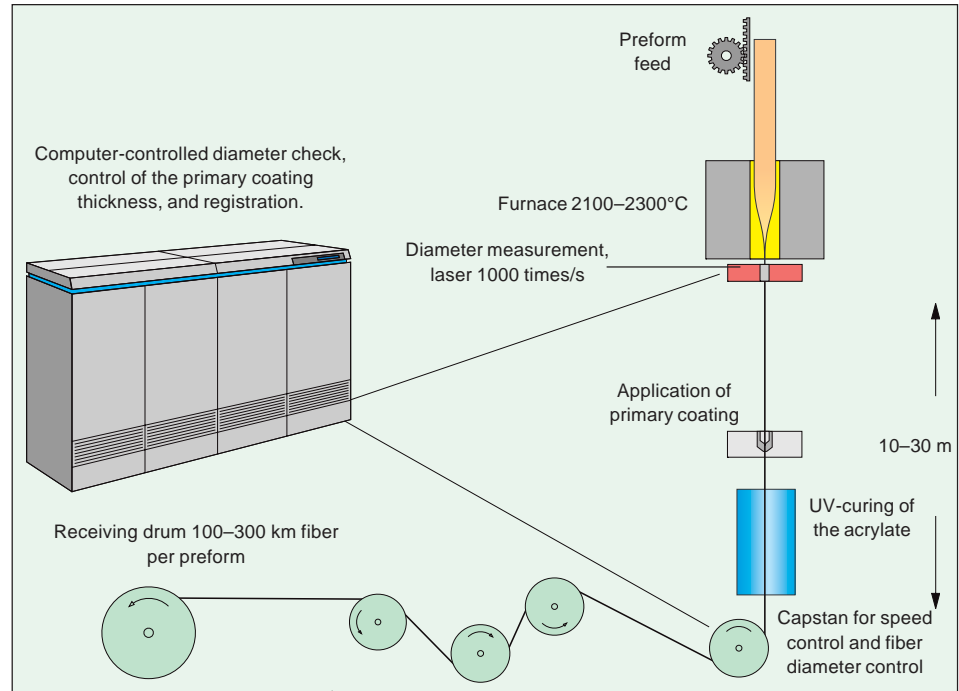

Fig. 3-11 Fiber drawing - principle drawing

From Fig. 3-11 it is clear that the bare glass is coated with a material. The glass cannot be too hot before the application occurs, therefore it is necessary to build very high towers or introduce a controlled cooling. Depending on the technique, the drawing speed is normally 600 to 1 500 m/min. The industry is trying to increase the speed further.

A controlled cooling can be performed using helium. The drawn fiber has the same geometrical relationships between the cladding and the core as the preform.



Fig. 3-12 Fiber drawing - top of the tower

The fiber is coated in the drawing tower with a protective acrylate, the primary coating. This coating consists of two layers of acrylate, the softer inner and the harder outer layer (see Fig. 3-13). The two acrylates can be applied in line using two dies or in a wet-on-wet die, where both acrylates are applied simultaneously. After application the acrylate is cured by UV radiation. The curing rate also influences on the possible drawing speeds. Proper curing is needed for several reasons, the simplest being to avoid a sticky material. The coating geometry is monitored a second time and the diameter of the primary coating and its centering around the fiber are checked. The fiber will now have its final diameter: normally  $245 \pm 10 \mu\text{m}$ .

Taking the above into account it has been cited in various papers that if everything works according to theory the maximum drawing speed with present materials and techniques is 2 500 m/min. But that presupposes that everything is perfect: Winding, curing, fiber geometry... .

Why is the fiber coated with a soft and a hard acrylate?

- Increase the fiber strength
- Protects the glass from very small bends - microbends
- Mechanical protection
- Facilitates handling

Fiber reliability including mechanical reliability is an area, which will not be discussed in detail. It is beyond the scope of this book.

### Proof test

The entire fiber length is exposed to a tensile test to reveal any cracks or other damage. Bad winding of a fiber spool can create loops that give a fiber weak spots. It is important to control the process in the furnace. Otherwise that also can create fiber with weak spots. The fiber is exposed to a specified tension for a short period. This period should be long enough to allow the glass to be exposed to the force, but short enough to avoid any unnecessary weakening of the fiber. The time needed is a few tenths of a second. Different levels of proof-testing can occur depending on the application. A standard level today is equivalent to a one per cent strain of the fiber. After the proof test the fiber is transferred to a measurement area for transmission and geometry characterization. From one preform typically 400 - 600 km fiber is obtained. After the final characterization the fiber is wound onto fiber spools. Today the maximum standard length is 50 km mostly due to measurement restrictions. However, a combination of quality, measurement accuracy and the increased fiber volume demand with a fast fiber flow through the factory finally sets the optimum length for fiber on shipping spools.

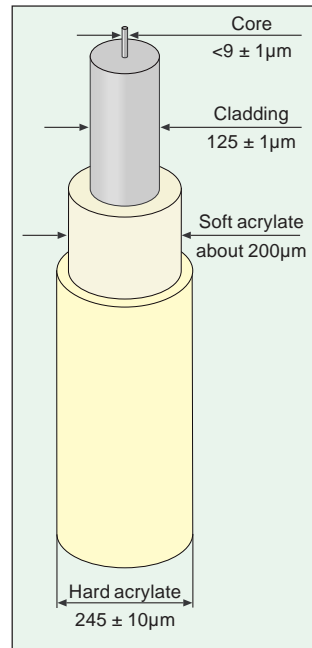

Fig 3-13 Typical primary coated single-mode fiber.

## Chapter 4

# Optical fibers and their parameters

When the refractive index for an optical waveguide is seen as a function of the waveguide's radius, the expression "index profile" can be used to describe how light is conducted through the waveguide. The index profile indicates how the refractive index changes from the waveguide's central axis to its periphery, or cladding. Light will be conducted and/or refracted in accordance with this profile. The refractive index is given as a function of the radius:

$$n = n(r) \quad \text{Formula 4-1}$$

The propagation of the light's modes in a waveguide is dependent on the index profile.

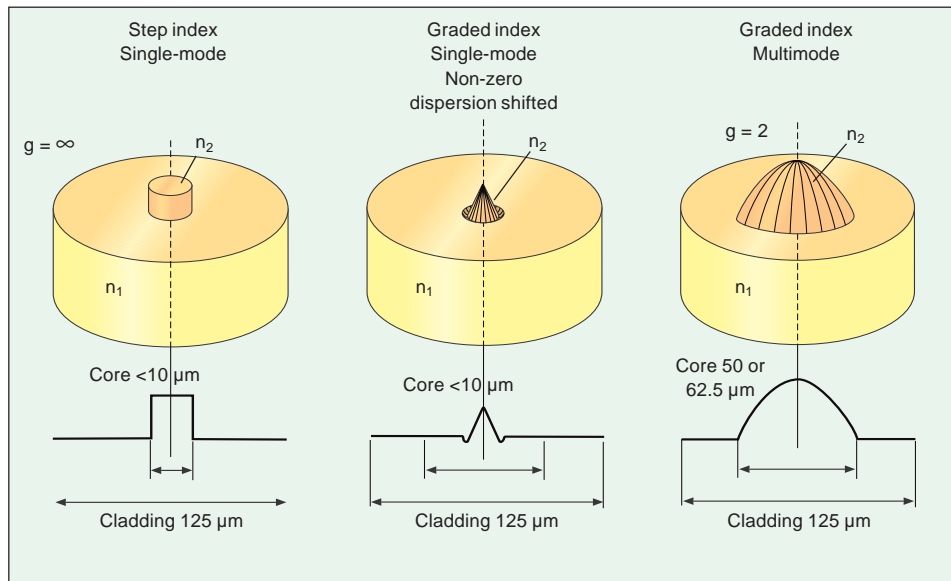

Fig. 4-1 Graphic representation of three different types of how the refractive index change in the core of an optical fiber.

The index profile can be mathematically described by the formula below. Its main significance is for practical applications, particularly the use of multimode fiber.

$$n(r) = n_2 \left[ 1 - \Delta \left( \frac{r}{a} \right)^g \right] \quad \text{Formula 4-2}$$

where for the cladding

$$n(r) = n_1 = \text{constan t} \quad \text{Formula 4-3}$$

and further:

- $n_2$  = the refractive index for the core (waveguide)
- $\Delta$  = differential for the normalized refractive index
- $r$  = distance from the fiber's central axis in  $\mu\text{m}$
- $a$  = the core's radius in  $\mu\text{m}$
- $g$  = profile index
- $n_1$  = the cladding's refractive index.

The expression normalized refractive index is linked to the numerical aperture (NA), or both the refractive indices  $n_1$  and  $n_2$ , as follows:

$$\Delta = \frac{NA^2}{2n_2^2} = \frac{n_2^2 - n_1^2}{2n_2^2} \approx \frac{n_2 - n_1}{n_2} \approx \frac{\Delta n}{n} \quad \text{for } \Delta \ll 1 \quad \text{Formula 4-4}$$

For the profile index “g”, there are a couple of special cases worthy of note.

- $g = 1$  for triangular index profile
- $g = 2$  for parabolic index profile
- $g = \infty$  for rectangular step index profile

It is only in the last case (i.e.,  $g = \infty$ ) that the refractive index is a constant:  $n(r) = n_2$  for the entire core's diameter. In other cases, the refractive index changes gradually from the central axis of the core ( $n_2$ ) along the diameter to the cladding ( $n_1$ ).

Profiles where the refractive index varies are termed graded index profiles. The most common type of graded index profile is where  $g = 2$  (parabolic) which, technically, gives an excellent light conducting multimode fiber.

## Modes

Modes are mathematical and physical ways of describing the propagation of electromagnetic waves in an arbitrary medium. In its mathematical form, the theory of electromagnetic modes derives from Maxwell's equations. James Clark Maxwell was a physicist and mathematician in Scotland at the end of the 19th century. With his equations, Maxwell showed that electric and magnetic energy are two forms of the same electromagnetic energy. His equations also showed that propagation follows strict rules. Maxwell's equations are the basis of the theory of electromagnetism.

A mode is a permitted solution to Maxwell's equations. For the sake of simplicity, a mode can be described as a possible direction (route) that a light wave will follow down, for example, an optical fiber. The number of possible modes or energy directions that can occur in a fiber ranges from one to over a hundred thousand. Exactly how many modes can be carried by a fiber is determined by the fiber's geometric properties (dimensions) together with the fiber's optical parameters.

A certain mode will also transport a certain amount of energy. The fiber used today is either of the type that transmits only one mode (called single-mode fiber), or of the type that transmits generally hundreds of modes (called multimode fiber).

When light enters a fiber (close to the light source), the various modes will carry either too much or too little energy, depending on the injected light. Along the path of propagation, energy will then be transferred between the different modes (called mode coupling) until each mode is carrying its specific amount of energy. When the light has reached this stage, a steady state or equivalence between the modes occurs. In plastic fiber, this occurs after a couple of meters along the fiber. For a high-quality glass fiber, it occurs only after several hundreds of meters up to a kilometer. This results in certain measuring difficulties, see the chapter entitled “Optical fiber measuring instruments and testing in single-mode networks”.

### Normalized frequency and modes

An important distinguishing feature of different types of optical fiber is the normalized frequency (V) and the number of modes (N).

The following parameters affect the value of V:

- a = core radius [ $\mu\text{m}$ ]
- NA = numerical aperture
- $\lambda$  = wavelength [ $\mu\text{m}$ ]
- k = number of light wavelengths per  $2\pi$  units of length.

The formula is written thus:

$$V = 2\pi \frac{a}{\lambda} \text{NA} = k \cdot a \cdot \text{NA} \quad \text{Formula 4-5}$$

The number of modes that can pass through the fiber core is dependent on the parameter V and can be approximated for a step index fiber. The number of modes N is approximated by:

$$N \approx \frac{V^2}{2} \cdot \frac{g}{g+2} \quad \text{Formula 4-6}$$

For a step index fiber with  $g = \infty$ , the number of modes N is approximated by:

$$N \approx \frac{V^2}{2} \quad \text{Formula 4-7}$$

For a graded index fiber with  $g = 2$  (normal parabolic graded index fiber), the number of modes N is approximated by:

$$N \approx \frac{V^2}{4} \quad \text{Formula 4-8}$$

The following calculation shows that in a fiber with a relatively large core, a large number of modes can be transmitted. Such a fiber is termed multimode fiber.

Calculation example
---------------------

Consider an optical fiber with:

graded index profile  $g = 2$   
 core diameter  $2a = 50 \mu\text{m}$  ( $a = 25 \mu\text{m}$ )  
 numerical aperture  $NA = 0.2$  at  $\lambda = 1 \mu\text{m}$

The value of  $V$  can then be calculated using the formula given above as:

$$V = 2\pi \frac{25}{1} \cdot 0.2 = 2 \cdot \pi \cdot 5 \approx 31.4 \quad \text{Formula 4-9}$$

The number of modes is thus:

$$N = \frac{V^2}{4} = \frac{31.4^2}{4} \approx 247 \quad \text{Formula 4-10}$$

If the number of modes is to be reduced, i.e., the parameter  $V$  reduced, one or more of the following parameters must be changed so that:

- the core diameter is smaller
- the numerical aperture is smaller
- the light wavelength is longer.

By making changes in one or the other direction, a single-mode fiber can be produced. These changes bring with them a number of complications. For example, a decrease in the numerical aperture will cause problems with the amount of light that enters the fiber, which means that the NA should be as large as possible. Another factor is attenuation in silica glass at different wavelengths (choice of transmitting wavelength). Finally, it is more difficult and expensive to manufacture laser diodes, light-emitting diodes (LED) and photodiodes that can receive longer wavelengths.

### LP<sub>01</sub> mode - the fundamental mode and cut-off

In a fiber with a step index profile ( $g = \infty$ ), to ensure light transmission in only one mode, the fundamental mode, requires that  $V \leq 2.405 = V_c$ . A fiber which fulfils this requirement is called a single-mode fiber.

The constant  $V_c = 2.405$  is the  $x$  value obtained when the fundamental mode of the Bessel function  $J_0(x)$  makes its first zero crossing. The Bessel functions look like attenuated sine curves, and are common in the description of wave propagation in symmetrically cylindrical waveguides such as coaxial cable, hollow waveguides (microwaves) and optical fiber.

In the constant  $V_c$ , the  $c$  stands for the cut-off wavelength. If you want to calculate the cut-off wavelength, the value of  $V_c$  must be calculated for the index profile of the existing fiber. For a single-mode fiber,  $V_c = 2.405$ .

The cut-off wavelength can be calculated with the formula.

$\lambda_c = \pi \frac{2a}{V_c} NA = \pi \frac{2a}{2.405} \cdot NA$	Formula 4-11
---	--------------



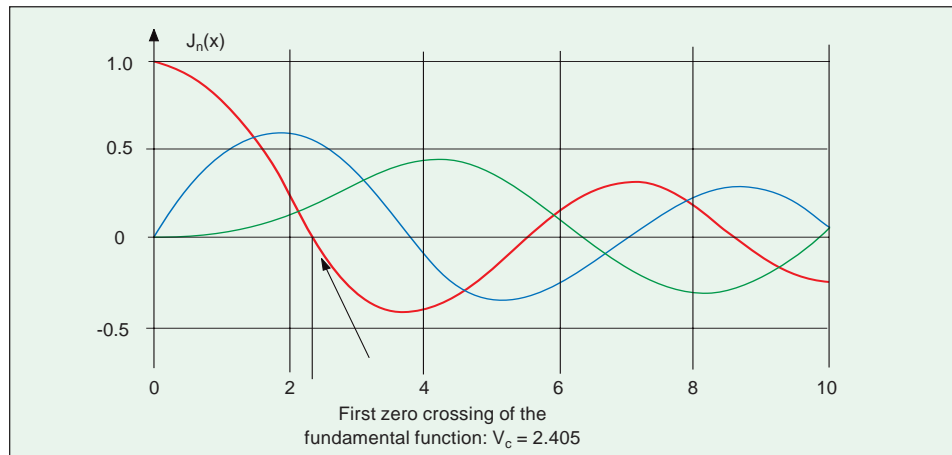

Fig. 4-2 Graph of the Bessel function.

#### Calculation example

For an optical fiber with a rectangular index profile and the following parameters:

core diameter  $d = 2a = 8.5 \mu\text{m}$

numerical aperture (NA) = 0.11

the critical wavelength, or cut-off wavelength  $\lambda_c$ , is calculated using the formula above:

$$\lambda_c = \pi \frac{2a}{V_c} \text{NA} = \pi \frac{8.5}{2.405} \cdot 0.11 \approx 1220 [\text{nm}] \quad \text{Formula 4-12}$$

*Note that this is a theoretical calculation only*

This means that for all wavelengths  $\geq \lambda_c$ , only one mode can propagate in the waveguide. An optical fiber carries light of these wavelengths as a single-mode fiber.

It is important to realize that cut-off has several definitions and that it is also a function of bends and other geometrical definitions.

In a real case these factors influence. Therefore fiber- and cable-manufacturer often define both theoretical cut-off, fiber cut-off and cable cut-off. The cable cut-off is the lowest and guarantees single-mode operation provided certain conditions are fulfilled.

Finally remember that all modes, including the fundamental mode, in fact (through polarization) consist of two modes oscillating perpendicular to each other.

### Numerical aperture

When light is injected into a fiber opening (see Figure 4-3), it is refracted in relation to the normal, producing a somewhat higher value for this incident angle, the acceptance angle. The sine value of the acceptance angle is defined as the numerical aperture (NA) and is calculated by means of the refractive index of the two materials involved:

$$\sin \beta = \sqrt{n_2^2 - n_1^2}$$

Formula 4-13

The opening through which light enters the fiber is in fact three-dimensional. Thus the acceptance angle is the angle of a cone, called the acceptance cone (see Figure 4-3).

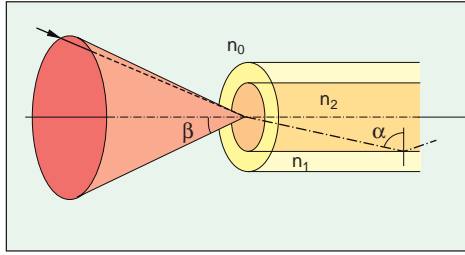

Fig. 4-3 The acceptance cone of a fiber.

### Numerical aperture for a fiber with graded index profile

Because the refractive index of a fiber with a graded index profile varies with the distance from the fiber center  $n(r)$ , the acceptance angle also varies for light entering the fiber. The acceptance angle is therefore a function of  $r$  as shown in the following formula:

$$\sin \beta(r) = \sqrt{n_2^2(r) - n_1^2} = NA \sqrt{1 - \left(\frac{r}{a}\right)^2} \leq NA \quad \text{Formula 4-14}$$

This means that the acceptance angle is greatest close to the center of the fiber, with a gradual reduction of the value towards the cladding. For a standard graded index fiber, the numerical aperture (with values from the example) is:

$$NA = n_2 \sqrt{2 \cdot \Delta} = 1.46 \sqrt{2 \cdot 0.01} \approx 0.206 \quad \text{Formula 4-15}$$

This gives the maximum acceptance angle  $\beta_{\max}$  as follows: this angle is located closest to the fiber center.

$$\sin \beta_{\max} = NA \approx 0.206; \Rightarrow \beta_{\max} \approx 12^\circ \quad \text{Formula 4-16}$$

On closer analysis, it can be seen that a graded index fiber with a core diameter of  $50 \mu\text{m}$  accepts only half of the light that a step index fiber with the same core diameter will accept.

The distribution of modes is such that lower-order modes propagate along the fiber's central axis, higher-order modes propagate closer to the cladding, and some modes disappear into the cladding. The latter are termed leaky modes. Leaky modes are radiated to some extent and propagated in the fiber to some extent.

### Group refractive index

The refractive index values sets of tables list only the index of the material itself, alone. In an optical fiber, two or more types of glass are combined, and then there is the acrylate used to provide the primary coating. The refractive indices of these materials differ slightly from each other (typical values are for the core 1.4485, the cladding 1.4440 and the primary coating acrylate 1.53). When a light pulse is transmitted in a medium, a different parameter, group refractive index is being used. For the typical fiber with slightly differing values for the core, cladding and primary coating, the group refractive index value will be somewhat greater than the refractive index of the core. This is a very important fact to remember when

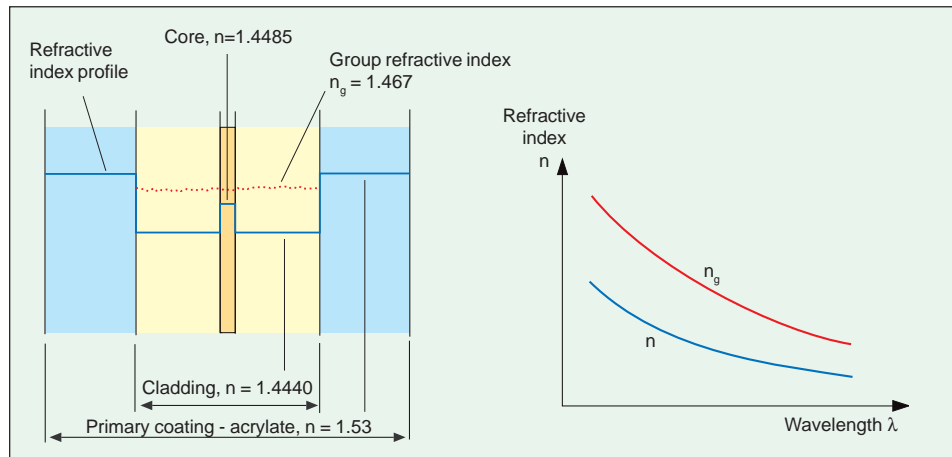

Fig. 4-4 Refractive index profile for a primary coated fiber including the refractive index for the acrylate. Diagram shows the refractive index and group refractive index versus wavelength used.

setting optical instrument (such as the OTDR), as their function is based on the speed of light through the measured media.

The speed of each light pulse through the fiber is described by the formula:

$$v = \frac{c}{n_g} \Rightarrow n_g = \frac{c}{v}; \quad n_g = n - \lambda \frac{dn}{d\lambda} \quad \text{Formula 4-17}$$

where  $v$  is the velocity of the light pulse through the fiber,  $c$  is the velocity of light in vacuum, and  $n_g$  is the group refractive index of the fiber.

### Mode field diameter

The term mode field diameter  $2w_0$  has been introduced in fiber optics to describe the radial propagation of the fundamental mode  $LP_{01}$  in the fiber. To produce a fiber with low attenuation (step index fiber) which permits propagation of the fundamental mode only in the wavelength range above 1200 nm, the mode field diameter  $2w_0$  is reduced to around  $9 \mu\text{m}$ . A fiber which only permits the transmission of the fundamental mode is called a single-mode fiber.

### Effective area

The effect of chromatic dispersion (described later) in the 1550 nm window was dramatically reduced with the introduction of dispersion shifted fiber. One drawback of this fiber is that the effective area of the core decreased. This is the area of the core that guides the light through the fiber, related to but not equal to the mode field diameter. The effective area of a standard single-mode fiber is around  $80 \mu\text{m}^2$  and for the dispersion shifted fiber the effective area is around  $55 \mu\text{m}^2$ . With the introduction of new high-power transmitting lasers and EDFA (Erbium Doped Fiber Amplifiers) the injected power caused unwanted non-linear effects in the system. Around 1996 larger fiber manufacturers introduced non-zero dispersion shifted fibers. Thus introducing high performance fiber with large capacity both in long-haul communication and high bitrates.

## Dispersion

Light travelling through a waveguide will be subjected to distortion. The emitted light will be spread out in time. In the field of fiber optics this is called dispersion. There are two different kinds of dispersion:

- Intermodal dispersion occurs in a multimode fiber
- Intramodal dispersion (chromatic) occurs in the single-mode fiber and also in the multimode fiber

### Intermodal dispersion

A light pulse that propagates in a multimode fiber should be seen as a large number of subpulses, each with its own angle of incidence into the fiber. The light pulses will thus follow different ray paths through the fiber. The length of the ray path varies due to the incident and reflection angles. The simultaneously emitted light pulses will thus reach the end of the fiber at slightly different times. It may be described as a broadening of the pulse (during its propagation through the fiber) due to an increase in pulse duration. The phenomenon is highly detrimental to fiberoptic communication.

As an example, light propagates through a 1 km long fiber in about 5  $\mu$ s. For the example above, the time difference will be  $\delta t = 50$  ns.

The time delay of individual modes distorts the original signal or light pulse.

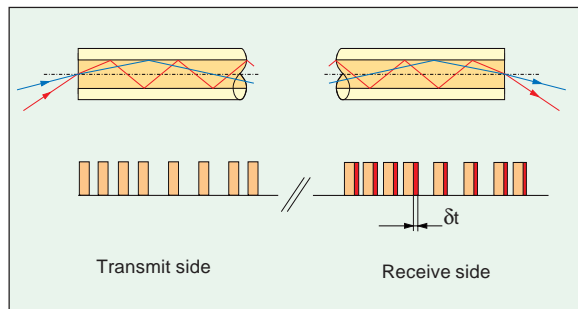

*Fig. 4-5 Because the different modes follow different paths through the fiber, a light pulse is broadened in proportion to the length of the fiber.*

Modal dispersion causes:

- a reduction of the transmission capacity (Mbit/s)
- a reduction of the transmission distance

There is a certain “natural” reduction of the effects of modal dispersion in a fiber. The individual modes cooperate and transfer energy to and from each other. Modes of a lower order (modes with a smaller angle to the fiber axis) become higher-order modes (modes with a larger angle to the fiber axis) after energy transfer. Mode coupling, as this is termed, occurs at points of impurities in the core, at splices, and at sharp bends in the fiber. In modern fibers, it has been possible to reduce mode coupling by increasing the quality of the fiber. The result is a certain neutralization of the time difference  $\delta t$ . This difference does not increase linearly with the length of the fiber but as follows:

$$\delta t \approx \sqrt{\text{fiber length}(L)}$$

*Formula 4-18*

Modal dispersion can be eliminated entirely by reducing the core diameter so that only one mode, the  $LP_{01}$  mode, can propagate in the fiber, a single-mode fiber.

## Intramodal dispersion or chromatic dispersion

Even if intermodal dispersion is completely eliminated by permitting only the fundamental mode to propagate in the single-mode fiber, there still will be dispersion of this mode as well. Distortion of this type is called intramodal dispersion and polarization mode dispersion. The intramodal dispersion or chromatic dispersion in a single-mode fiber consists of material dispersion and of waveguide dispersion.

Material dispersion and waveguide dispersion tend to cancel each other out in wavelengths close to 1310 nm where the chromatic dispersion is zero. For shorter wavelengths, the chromatic dispersion is negative, and for longer wavelengths, it is positive. Material dispersion can only be changed by varying the composition of the glass in the fiber core and cladding. Waveguide dispersion is caused by the profile of the waveguide and can only be changed by changing the refractive index profile.

The primary reason for chromatic dispersion is the transmitting light source. A laser is not entirely monochromatic, which means that each light pulse emitted contains light that is both somewhat towards the red end, and somewhat towards the blue end of the spectrum for the specific wavelength being used. This is called spectral width, and for a wavelength range of 1 - 1.5  $\mu\text{m}$ , a laser diode has a spectral width of 0.1 - 1 nm and a light emitting diode (LED) a spectral width of 50 - 100 nm. The chromatic dispersion is zero or close to zero at 1310 nm for a normal single-mode fiber. The minimum attenuation of the fiber occurs at around 1550 nm. This has led to special fibers being manufactured for which the dispersion's zero crossing is shifted towards higher wavelengths. See also chapter 9.

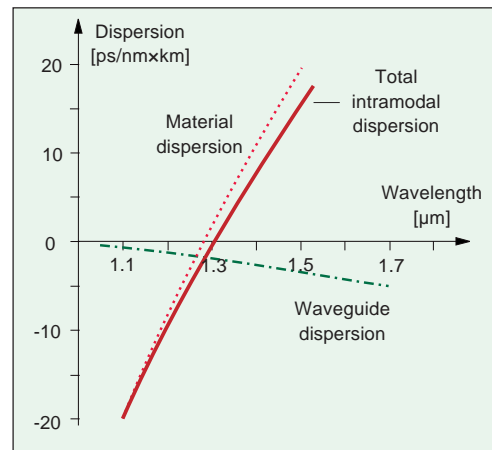

Fig. 4-6 The chromatic dispersion is the sum of material- and waveguide dispersion.

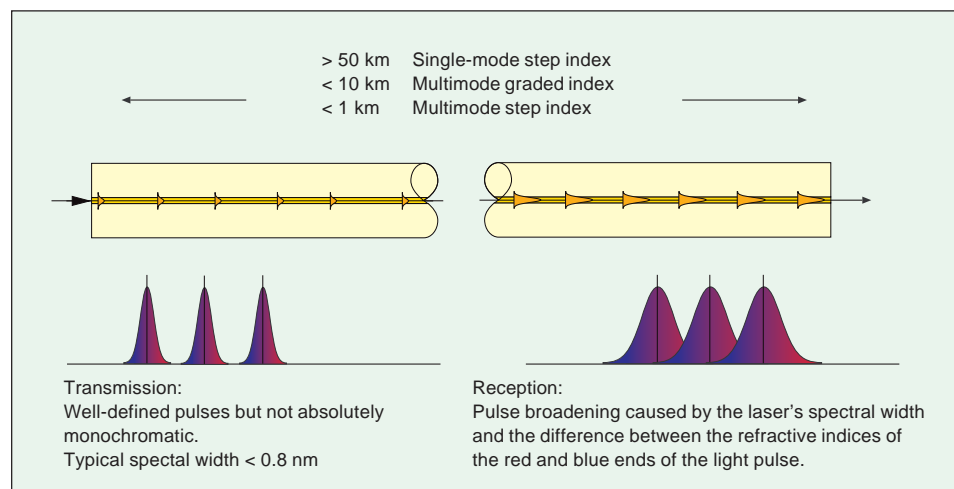

Fig. 4-7 Pulse broadening through dispersion. In single-mode fiber, intramodal and PMD dispersion occurs; in multimode fiber, modal dispersion causes the greatest amount of pulse broadening.

## Polarization mode dispersion, PMD

Single-mode transmission is never really single-mode. There are always two modes, see also “Chapter 2”. When light enters the fiber from the laser, these two fields are synchronous with field vectors that maintain a  $90^\circ$  angle to one another. Each field represents a polarization “mode”.

The difference in the arrival times of the two polarization modes is called polarization mode dispersion, PMD, and is measured in the units of picoseconds (ps).

Scaled to one kilometer the PMD coefficient of an optical fiber is expressed in the units of  $\text{ps} / \sqrt{\text{km}}$ . This is due to mode coupling (to explain this is beyond the scope of this book). Some of the earlier optical fibers and some low quality fibers still manufactured, have PMD coefficients up to  $6\text{ps} / \sqrt{\text{km}}$ , while high quality fibers have less than 0.2. Standardization organizations are proposing that the PMD of an optical path should not exceed 1/10 of the bit period. One tenth of a bit period translates into a maximum PMD of 40 ps for a 2.5 Gbit/s system and 10 ps for a 10 Gbit/s system.

For a 400 km long route these values translate into a maximum PMD value of  $40 / \sqrt{400} = 2.0 \text{ ps} / \sqrt{\text{km}}$  for the 2.5 Gbit/s system and  $10 / \sqrt{400} = 0.5 \text{ ps} / \sqrt{\text{km}}$  for the 10 Gbit/s system. The 0.5 value is set as the standard value required for fibers in fiber optic cables.

New requirements for still higher bitrates would be 0.1 for 40 Gbit/s.

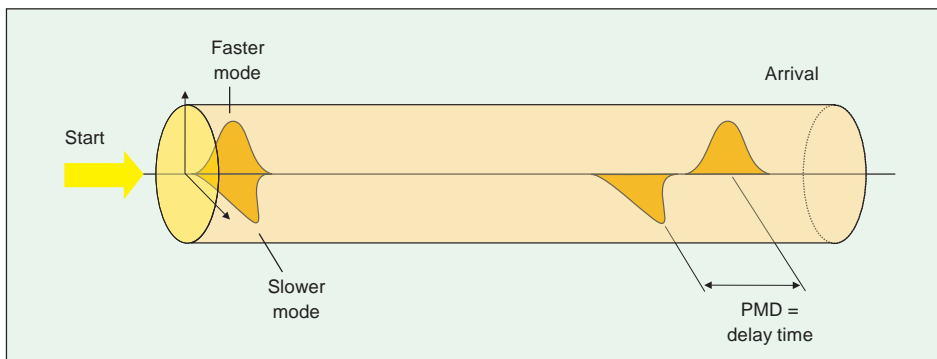

Fig. 4-8 Pulse broadening through polarization mode dispersion, PMD.

## Nonlinear effects

The input power into an optical fiber has steadily increased. The introduction of optical power amplifiers, combined with the simultaneous transmission of multiple wavelengths raised the importance of the phenomena, nonlinear effects.

Fiber nonlinearities fall into two categories

- stimulated scattering
- refractive index fluctuations

The power levels at which these various phenomena arise are called “thresholds”. To describe these phenomena in depth is beyond the scope of this book, therefore, only a brief description will be given except regarding four-wave mixing, as this is the first phenomena that has to be dealt with in the case of wavelength division multiplexing.

### Stimulated Brillouin Scattering, SBC

Stimulated Brillouin scattering is an interaction between light and acoustic waves in an optical fiber. Some of the forward propagating light is redirected backwards thereby stealing power from the forward propagating light, thus reducing the power that can be delivered to the receiver. SBC arises at an input power level from 6–20 dBm.

### Stimulated Raman Scattering, SRS

Stimulated Raman scattering is an interaction between light and the fiber's molecular vibrations. The SRS scatters light in both in the forward and backward direction, the backward propagating power can be eliminated by the use of an optical isolator. SRC arises at an input power level above 27 dBm, close to 1 W.

### Self Phase Modulation, SPM

Self Phase modulation describes the effect an optical pulse has on its own phase. The edge of an optical pulse represents an intensity that is time-varying thus implicating a time-varying refractive index. The varying refractive index modulates the phase of the transmitted wavelength(s), this broadens the wavelength spectrum of the transmitted pulse. If sufficiently severe, this broadening may overlap into adjacent channels in DWDM systems. SPM arises at an input power level above 5 dBm.

### Cross Phase Modulation, CPM

Cross Phase modulation originates the same way as SPM. Whereas SPM relates to the effect that a pulse has on itself, CPM describes the effect that a pulse has on the phases of pulses in other channels. SPM may occur both in single- and multi-channel system and CPM will only occur in multi-channel systems. CPM arises at an input power level above 5 dBm.

### Four-Wave Mixing, FWM

One of the most troubling of the nonlinear effects is the four-wave mixing. It occurs when multiple signals co-propagate, they mix to produce additional channels that can steal power from and overlap with the original signals. Figure 4-9 illustrates this for three evenly spaced channels  $\lambda_1$ ,  $\lambda_2$  and  $\lambda_3$ . The mixing components occur at  $\lambda_{xyz} = \lambda_x + \lambda_y - \lambda_z$ . Because of the even spacing of the original wavelengths in

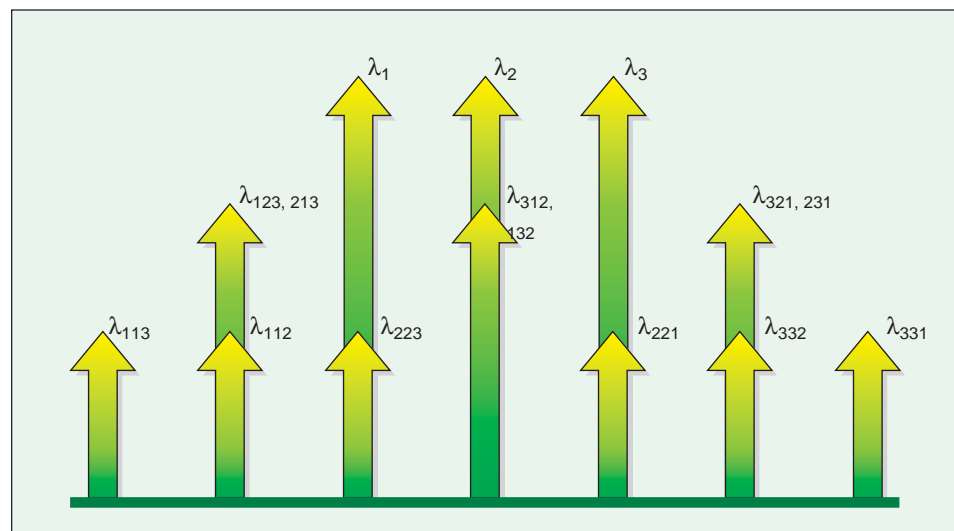

Fig. 4-9 Because of the three evenly spaced wavelengths (channels)  $\lambda_1$ ,  $\lambda_2$  and  $\lambda_3$  in this example, some of the newly generated signals occur at the original wavelengths.

this example, some of these newly generated signals occur at the original channels. FWM arises at an input power level above 0 dBm.

The total number of mixing wavelengths (channels) generated,  $mw$ , is calculated as  $mw = 1/2 (N^3 - N^2)$  where  $N$  is the number of original wavelengths (channels). For a 3-channel system, this means there are 9 wavelengths to contend with. For a 16-channel system, the number of generated wavelengths (channels) are 1920.

The FWM process is most significant at the zero-dispersion wavelength, in direct conflict with the need to keep the dispersion to a minimum. The standard dispersion-shifted fiber, has its zero-dispersion wavelength within the operating area of the EDFAs, these conflicting requirements place limits on the capability of this fiber for high-data-rate long-haul networks using wavelength division multiplexing (WDM). The non-zero dispersion-shifted fiber is a much more suitable fiber to deal with the problems described above.

## Multimode fiber with rectangular index profile

If a fiber with a rectangular index profile (plastic fiber, or simple glass fiber with quartz core and plastic cladding) is to be used to transmit light utilizing the principle of total reflection, the refractive index ( $n_2$ ) of the core must be higher than the refractive index ( $n_1$ ) of the cladding. If the refractive index of the core is constant over the entire core radius, the fiber is called a step index fiber. The Figure 4-10 shows the index profile (blue) and light refraction of a fiber with a step index profile.

This type of fiber is easy to manufacture, but because of its relatively poor transmission capabilities, it is only used for information transfer over very short distances.

Parameters for two typical step index fibers

	glass	plastic
core diameter $2a$	100 $\mu\text{m}$	980 $\mu\text{m}$
cladding diameter $D$	140 $\mu\text{m}$	1000 $\mu\text{m}$
core refractive index $n_2$	1.48	
cladding refractive index $n_1$	1.45	

### Calculation example

First, the critical angle  $\alpha_c$  at which total reflection occurs is determined. The light must be incident at a smaller angle than the critical angle of the fiber for it to function as a waveguide, and so that light does not escape out of the fiber through the cladding. For a glass fiber (with parameters as described above) this is calculated as follows:

$$\sin \alpha_c = \frac{n_1}{n_2} = \frac{1.45}{1.48} \approx 0.9797; \Rightarrow \alpha_c \approx 78^\circ$$

From this we can see that all light at angles to the fiber's long axis smaller than or equal to  $(90 - \alpha_c) = 11.76^\circ$  will propagate along the fiber.



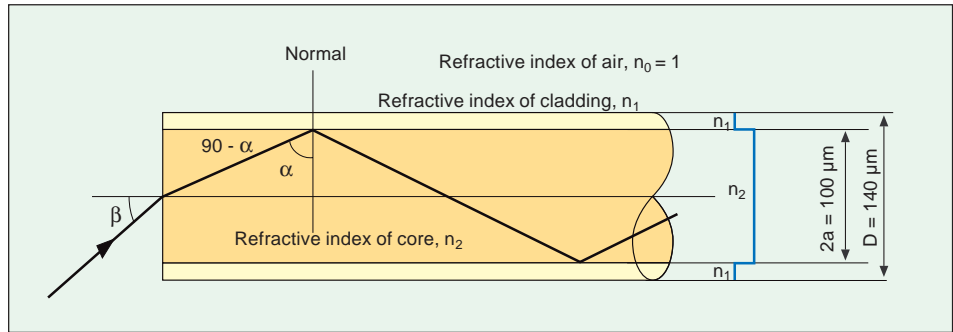

Fig. 4-10 Energy path in a step index, multimode fiber.  
 Note that the angle  $(90 - \alpha) < \beta$ .

### Multimode fiber with graded index profile

As previously outlined, a multimode fiber with a rectangular index profile transmits a large number of modes. Each one of these modes has a different path length through the fiber and, hence, each arrives at a slightly different time (termed modal dispersion) at the other end of the fiber. Modal dispersion can be reduced considerably if the refractive index can be made to vary from the core's center towards the cladding. The refractive index is permitted to vary parabolically so that the refractive index is at a maximum ( $n_2$ ) at the center of the fiber and drops to a minimum ( $n_1$ ) at the point of coupling to the cladding. A fiber which has an index profile that varies quadratically with an exponent  $g = 2$  is thus called a graded index fiber.

In Figure 4-11, four light waves (modes) have been drawn: one which passes along the fiber's central axis where the refractive index is at the maximum; one lower-order light wave (mode); and two higher-order waves (modes). The light travelling the longer path through the fiber is actually travelling through glass with a lower refractive index - and consequently travels faster despite the longer path. If the fiber's variation in refractive index can be made as close to a parabolic variation as possible, the modal dispersion will be very small. Dispersion in a multi-mode graded index fiber causes a time difference less than 1 ns over 1 km of fiber.

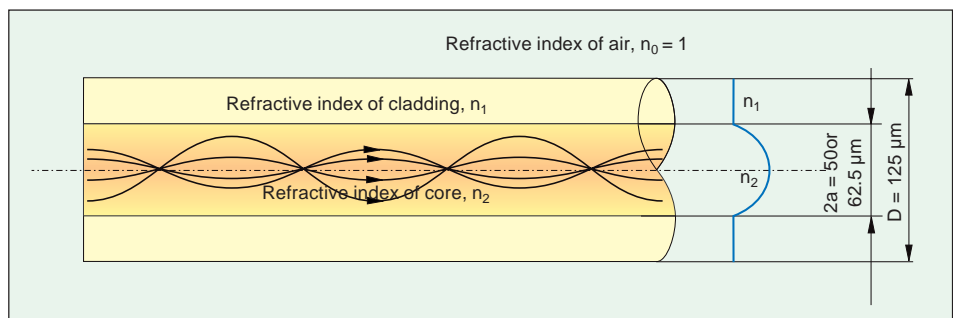

Fig. 4-11 Ray path in a graded index multimode fiber.

Typical values of a graded index fiber:

Core diameter $2a$	50 or 62.5 $\mu\text{m}$
Cladding diameter $D$	125 $\mu\text{m}$
Maximum refractive index, core	1.46
Relative differential refractive index	0.010

Light waves propagate through the fiber in a helical motion. Modal dispersion is caused by variations from the ideal parabolic profile in a fiber. Variations such as the relative differential in the refractive index and the profile exponential  $g$  are dependent on wavelength.

Multimode fibers are generally used in indoor networks. The larger core diameter allows simpler connection to transmission equipment. The fiber is used in data networks, sensor applications and it fulfills the requirements for FDDI (Fiber Distributed Data Interface) networks. Generally speaking multimode fiber means graded index multimode fiber. These fibers can be used at both 850 nm and 1300 nm or in dual window applications. For technical data see chapter 14 “Tables”.

## Standard single-mode fiber with rectangular index profile

Single-mode fibers are normally used in long distance telecommunication links. For standard single-mode the lowest dispersion is around 1310 nm and the lowest attenuation is found around 1550 nm. If the cut-off value and the mode field diameter are combined, an estimate of the fiber bend sensitivity can be obtained. High cut-off and a small mode field diameter will give a more bend resistant fiber.

The Figure 4-12 shows the passage of light through a standard single-mode fiber, and the refractive index profile of the fiber.

Typical values for a single-mode fiber are:

Cladding diameter $D$	125 $\mu\text{m}$
Core refractive index $n_2$	1.4485
Cladding refractive index $n_1$	1.4440
Refractive index differential	$0.003 = 0.3\%$

A fiber with the above parameters has a numerical aperture  $NA = 0.11$  which gives an acceptance angle  $\beta \approx 6^\circ$ .

It is not only the core diameter of a single-mode fiber that is significantly smaller than the core of a multimode step index fiber; the numerical aperture and acceptance angle are also considerably smaller. These three factors taken together make it more difficult to couple light into the fiber.

The cut-off wavelength ( $\lambda_c$ ) for the fiber in the example above can be calculated using the following formula:

$$\lambda_c = \pi \frac{2a}{V_c} NA = \pi \frac{9.2}{2.405} \cdot 0.11 \approx 1322 \text{ [nm]} \quad \text{Formula 4-20}$$

This calculation indicates the fiber cut-off. Fibers installed in a fiber optic cable will always have lower cut-off wavelength, the cable cut-off.

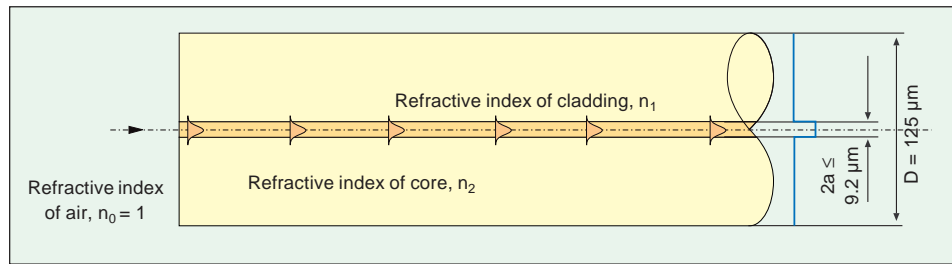

Fig. 4-12 Energy path in an ideal single-mode fiber.

Light of this or a longer wavelength can only propagate through the fiber in the fiber's fundamental mode ( $LP_{01}$  mode). The fiber is thus a single-mode fiber.

The dispersion un-shifted fiber (standard single-mode fiber) where introduced commercially 1983 and the transmission and geometrical properties has since then been more and more refined by the manufacturers. All high quality fibers manufactured today easily fulfil the specifications stated in the ITU recommendation G.652. See chapter 14 "Tables" for technical specification.

Figure 4-14 shows the refractive index profile (blue) for a standard single-mode fiber of the step index type with a difference  $\delta n$  in the refractive indices of the core and cladding. Waveguide dispersion and material dispersion cancel each other out at a wavelength somewhat greater than 1300 nm so that the total (chromatic) dispersion is zero at this point, see Figure 4-13.

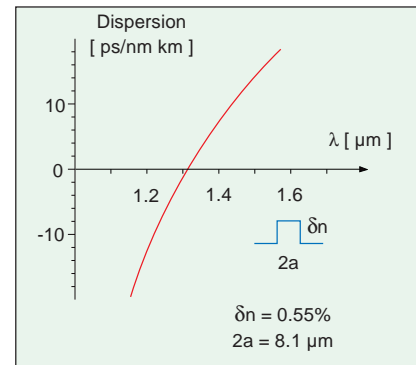

Fig. 4-13 Chromatic dispersion in a standard single-mode fiber for the interval 1150 - 1600 nm.

## Dispersion shifted fibers

For a variety of applications, such as long-haul transmission (low attenuation), systems with Erbium Doped Amplifiers (EDFA)(high power) and systems for wavelength division multiplexing (DWDM) it is necessary to shift the point of zero dispersion to other wavelengths (preferably to the 1550 nm wavelength band). Fiber with this characteristic is called dispersion-shifted fiber. When shifting the dispersion point of zero from 1310 nm to the 1550 nm wavelength band the result is a fiber with lower attenuation and lower dispersion. The shift in the zero dispersion point is achieved by a change in the refractive index profile of the fiber. The index profile may contain several steps or segments (called multistep or segmented fiber). Using this technique, a fiber can be made with zero chromatic dispersion freely within the 1530-1565 nm wavelength band, e.g. the C-band.

### Standard dispersion shifted fiber

The first dispersion shifted fiber was introduced in the mid-80s and it has its zero-crossing at 1550 nm (see Figure 4-14). The dispersion shift is obtained by making the core's index profile triangular or creating double steps in the cladding. It is

used for the long-haul high capacity applications e.g. submarine systems where long-link spans and high data rates are required. This type of dispersion shifted fiber has the disadvantage of having too low dispersion around 1550 nm, this creates non-linear phenomena under certain conditions. This “old” dispersion shifted fiber can not offer sufficient number of wavelength for the new wavelength division multiplexing systems introduced 1993. The fiber specifications are defined in the ITU G.653 recommendation.

The “standard” dispersion shifted fiber is now obsolete and is replaced in the new systems with the non-zero dispersion shifted fiber.

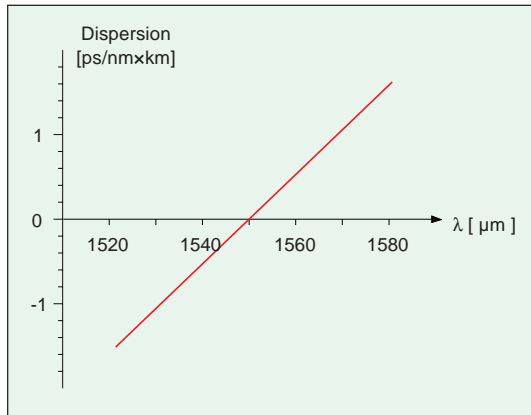

Fig. 4-14 Chromatic dispersion for a dispersion shifted fiber and the refractive index profile

### Non-zero dispersion shifted fiber

To meet the increasing demand for bandwidth the transmission systems has reached higher and higher bit rates. From the early stage of fiber optics lots of experimentation has been on utilizing several separate wavelengths to carry many information channels, thus multiplying the capacity in the fiber. The non-zero dispersion shifted fiber was initially developed for DWDM (dense wavelength division multiplexing) in the third window, 1530–1565 nm. Now even windows four and five are being considered for such fiber types. Therefore several variations of this fiber exist with essentially different dispersion and effective area values. Two examples are given in Fig 4-15.

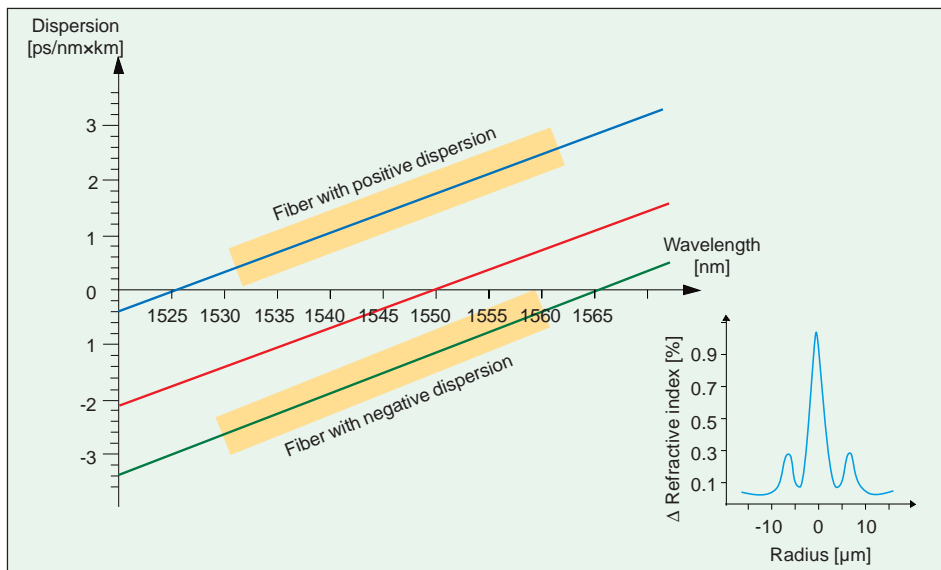

Fig. 4-15 Graph showing the different types of non-zero dispersion fibers compared with a dispersion shifted fiber (red), included is also the refractive index profile.

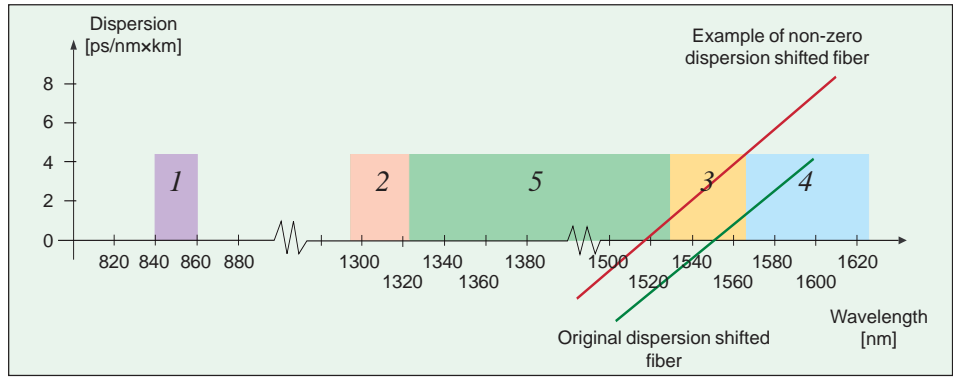

Fig. 4-16 Graph showing the chromatic dispersion in a non-zero dispersion shifted fiber and a dispersion shifted fiber. New techniques have opened two new windows, (4 and 5) for WDM. Window 3 is traditionally used for DWDM.

Non-linear effects such as four-wave mixing can be controlled by using a fiber with some dispersion and avoiding the zero dispersion point. Standard dispersion-shifted fiber cannot be used to handle WDM and non-linear effects at higher bit-rates without major technical efforts. The non-zero dispersion shifted fiber will in the range 1530–1565 nm may have a dispersion of 2–6 ps/nm×km. With this type of fiber several hundred channels of 2.5 or 10 Gbit/s have been transmitted over distances reaching several hundred kilometers. It is now standardized by ITU in the ITU G.655 recommendation.

**Fiber with a continuous usable bandspectrum from 1285 nm to 1625 (1700) nm.**

A newly developed fiber will open a new window for transmitting usage. The window will link the 1310 nm window with the 1550 nm window thus providing more than 100 nm optical bandwidth than the conventional single-mode fiber. In this fiber the “water peak” at 1385 nm has been reduced. The over all attenuation from 1285 nm to 1625 nm is now less than 0.4 dB.

With this type of fiber increased flexibility in providing different types of services is possible. For example the same fiber could be used for WDM analog video in

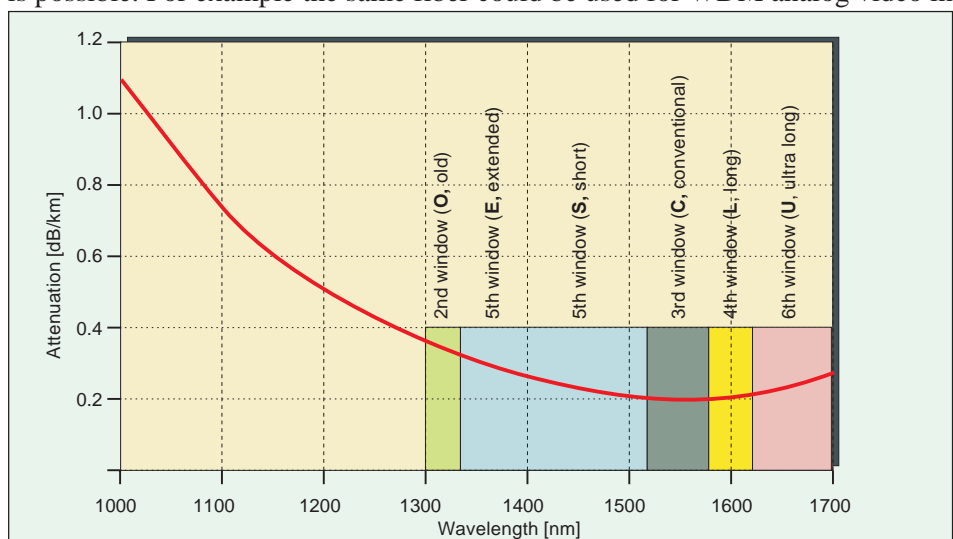

Fig. 4-17 Attenuation versus wavelength for the fiber with reduced “water peak”. The fiber may be used continuously for 1285–1625 nm.

the new 5th window (1350–1450 nm) and DWDM traffic at bitrates around 2.5 Gbit/s in the region above 1450nm. This type of fiber originates from the standard un-shifted single-mode fiber.

### Dispersion-compensating fiber

As described earlier in this chapter, it has only been cost effective to use dispersion-shifted fiber (which is expensive) for long transmission distances (greater than 100 km). With a combination of standard single mode fiber and amplifiers with erbium-doped fiber (EDFA) and dispersion-compensating fiber, longer transmission distances and higher transmission speeds can be obtained. A disadvantage, however, is that EDFA only propagates wavelength around 1550 nm, which, at least for the time being, excludes 1310 nm transmission wavelength.

Type of fiber	Dispersion at 1550 nm [ps/nm × km]	Attenuation at 1550 nm [dB/km]
Standard single-mode fiber	17 - 18	0.18 - 0.21
Dispersion compensating fiber	(-65) - (-90)	0.56 - 0.60

Table 1 Parameters for standard and dispersion compensated single-mode fibers.

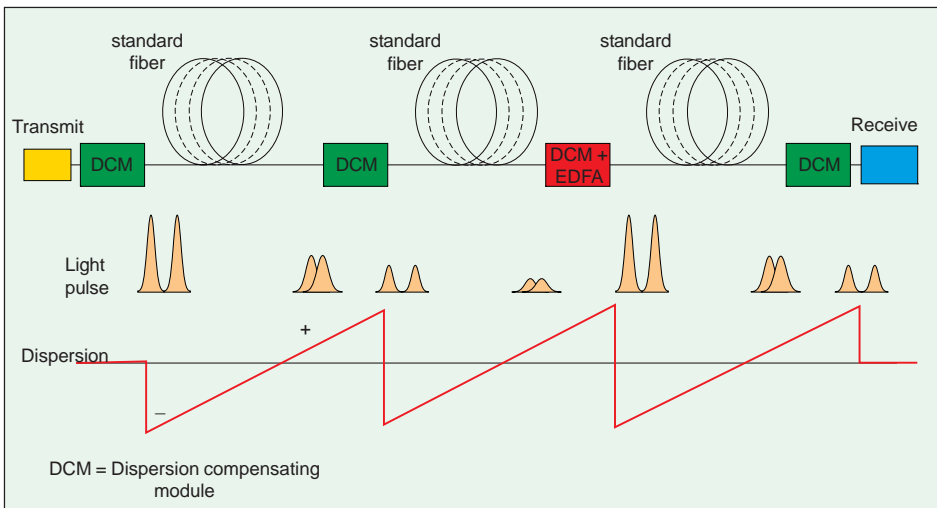

Fig. 4-18 The dispersion compensating modules can be used at the beginning, in the middle or at the end of a transmission link. They can preferably be combined with an EDFA.

As can be seen from the Table 1 above, the dispersion compensating fiber has a high negative dispersion at the transmission wavelength 1550 nm.

By introducing modules with dispersion compensating fiber or modules with both dispersion compensating fiber and EDFA in old and new fiber optic systems of standard fiber, cables can be made very long without any appreciable dispersion being measured. The only disadvantage of dispersion-compensating fiber is that the attenuation is relatively high (around 0.60 dB/km). However, this can be compensated by the use of EDFA. Standard single-mode step index fiber can thus be used for long transmission distances without introducing repeaters. Old fiber optic systems can be upgraded for higher transmission rates and also perform better in systems utilizing wavelength division multiplexing.

## Summary

From the very first low attenuation fiber produced 1970 by Corning, tremendous effort have been spent in developing better and better fibers. Fibers are produced today with extremely low attenuation. The dispersion is optimized depending on the type of system to be used and the bandwidth for single-mode fiber has been enlarged to improve the number of wavelength that can be used within on single fiber. The price per meter is today lower than for a simple insulated copper wire. The Figure 4-19 illustrates the history of the optical fiber and the introduction of fiber related systems.

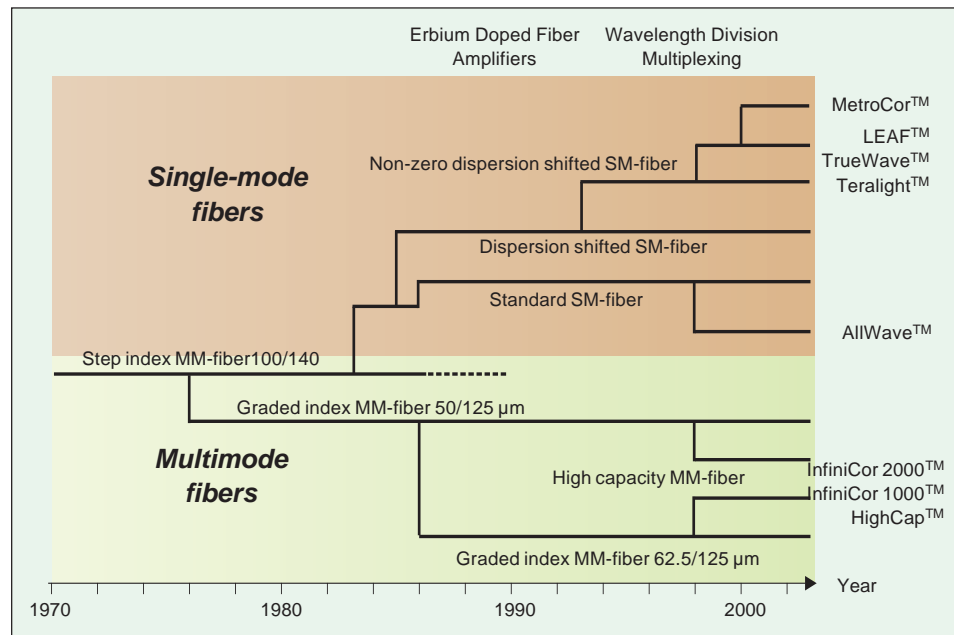

Fig. 4-19 The evolution of the optical fiber.

The fiber standard today is so wide that there are variations within one standard. This allow the fiber manufacturer to develop their own fibers within the standard. However, this means that it might create problems mixing fibers from different manufacturer.

- Standard single-mode fiber (all standard systems)
- Dispersion shifted fiber (out-moded today)
- Non-zero dispersion shifted fiber Truewave™ (Lucent) or Teralight™ (Alcatel) (wavelength division multiplexing)
- Non-zero dispersion shifted fiber with large effective area LEAF™ (wavelength division multiplexing and high output power lasers, Corning Inc.)
- Fiber with continuous usable spectrum from 1285–1625 nm, Allwave™ (Lucent Technologies)
- Pure silica fiber, low attenuation fiber with undoped core for submarine systems (Sumitomo)
- Multimode fiber with 50 μm core
- Multimode fiber with 62.5 μm core
- Laser optimized multimode fibers InfiniCor™ (Corning Inc) HiCap™ (Plasma Optical Fibre)
- Erbium doped fiber (amplifying fiber)
- Titanium doped fiber (strength)





## Chapter 5

# How to choose the right optical fiber cable

---

## Introduction

The design and production of optical fiber cable is in many ways similar to the design and production of copper cable. These similarities have made it possible for manufacturers of copper cable to begin parallel production of optical fiber cable. However, the physical properties of glass have necessitated the creation of a unique design concept for optical fiber cable, primarily at the beginning of the production process.

The principal differences between copper cable and optical fiber cable production arise from the properties of the conductors themselves: copper versus glass. In the design of optical fiber cable, special care must be taken to ensure that the fiber is not:

- bent too much, because:
  - it can easily break
  - it becomes a poorer light guide (light leaks out and is lost; attenuation increases)
  - the risk of cracks and breaks will increase if the fiber is subjected to longitudinal forces. Stretching the fiber only a percent will eventually result in the fiber breaking
- subjected to radial forces, since compression of the fiber increases attenuation
- subjected to moisture, since this breaks down the chemical composition of the fiber, resulting in attenuation increases and shortening of the life of the fiber.

It is not practical to use optical fiber without the various forms of protection that the cable construction provides. Designing an optical fiber cable thus involves packaging a very fragile light guide of glass in such a way that the above factors are avoided as far as possible – all within a manageable, useable, durable packaging that will last for decades. Fifteen years of research have resulted in the development of special designs for different areas of application to reduce stresses on the optical fiber. Standard cable designs have been developed for the following areas of application:

- Indoor cable
- Rack cable (flexible, often single fiber, patch cords, pig-tails)
- Duct cable
- Aerial cable
- Direct burial cable
- Submarine cable

## Many parameters

Figure 5-1 illustrates the many parameters that are involved in the choice of the correct optical fiber cable. Every large project has its unique specifications. To meet all required parameters and still be within a cable manufacturer's standard range of optical fiber cables might be an impossible task. A close relationship between customer and manufacturer is therefore of the utmost importance. Early co-operation between customer, cable manufacturer and subcontractors will, in most cases, result in an optical fiber network that fulfils specifications and is installed and "up-and-running" according to plans.

This chapter will deal with each major step (choice) in choosing the right optical fiber cable. A particular parameter chosen initially may exclude later parameters.

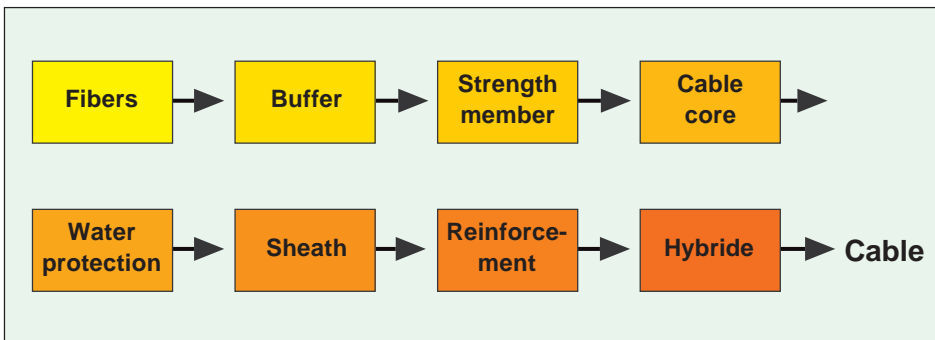

Fig. 5-1 General outline of the parameter involved in choosing the right optical fiber cable design.

## First parameter, the optical fiber

It is only during the first 1 - 3 seconds of its life that an optical fiber is unprotected. Before it leaves the drawing tower (in a clean-room environment) the fiber is given its first protective layer - the primary coating. A completely unprotected fiber is highly sensitive to bending and longitudinal tensile stresses, which can easily cause breakage. The unprotected fiber is also highly sensitive to moisture and chemicals.

Fibers come in a large number of geometrically different variants, but here we will deal only with fiber that has a cladding diameter of 125  $\mu\text{m}$ . Standard fibers in most networks today have almost exclusively one of these four types of fiber:

- Single-mode step-index fiber 8-10/125  $\mu\text{m}$
- Single-mode dispersion shifted fiber 4-8/125  $\mu\text{m}$
- Multimode graded-index fiber 50/125  $\mu\text{m}$
- Multimode graded-index fiber 62.5/125  $\mu\text{m}$

All of these fibers have a cladding diameter of 125  $\mu\text{m}$ .

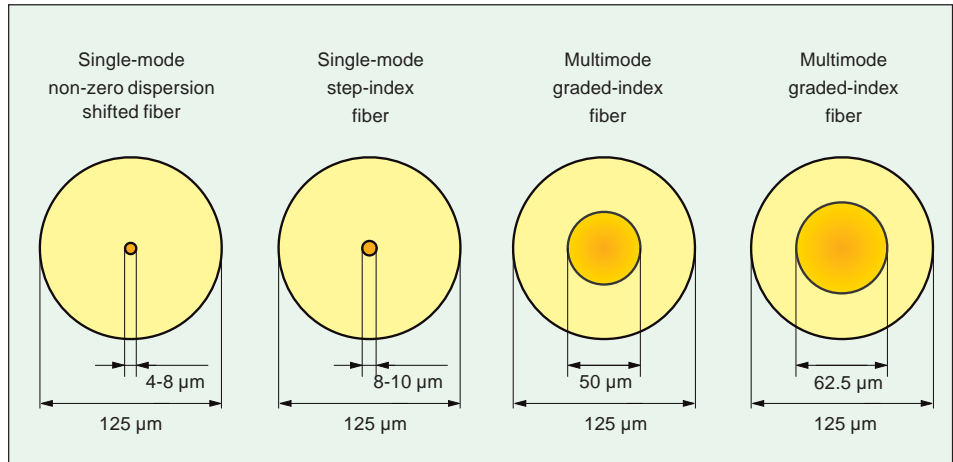

Fig. 5-2 The four most common types of fiber in fiberoptic networks today (no specific order).

### Primary coating

To be useable, the glass fiber must be coated with one or more protective layers of plastic. This occurs during the actual fiber drawing process, a few meters under the furnace in the drawing tower. The primary coating is applied in fluid form via one or more applicators that the fiber passes through at a speed of 300 - 900 m/min.

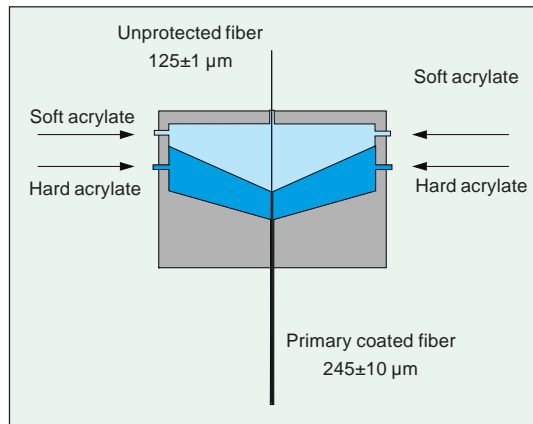

Fig. 5-3 Application of acrylate as the primary coating.

### Acrylate as the primary coating

Generally, two layers of acrylate are applied to the fiber in the same process: a soft inner one (to protect the fiber) and then a hard outer one (to protect the soft acrylate). The combined acrylate layers give the fiber a diameter of 245 ± 7 μm. The acrylate is cured by intensive irradiation with UV-light. It is very important that the acrylate is fully cured: a mixture

of cured and uncured acrylate can cause microbends, which in turn can cause attenuation increases. Uncured acrylate can also cause the fiber geometric values to change and thus exceed the strict tolerances stated in the fiber specifications. Improper curing of acrylate means that the fiber is more vulnerable in environmental testing. Uncured acrylate is also highly irritant (extremely allergenic). These factors mean that great care must be taken to ensure that the curing process is complete.

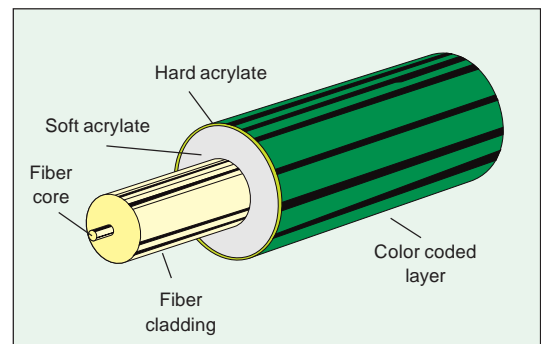

Fig. 5-4 Primary coated fiber.

## Silicon as the primary coating

Previously, silicon was commonly used as the primary coating, but in recent years its use has diminished, mainly because of problems associated with stripping off the primary coating before terminating the fiber with connectors. Cured acrylate, by contrast, is easily stripped from the fiber.

## The fiber characteristics after primary coating application

The primary coating greatly increases the glass fiber's mechanical strength. When the fiber is primary coated, it must be able to endure a tensile stress of 10 N to fulfil service life warranties. The ultimate tensile strength is around 50 N. The primary coating also protects the fiber from dust, moisture and chemicals.

Parameter	IEC 60793-2
Cladding diameter	125 ± 1 µm
Cladding non-circularity	< 1%
Coating diameter	245 ± 5 µm
Mode field concentricity error	< 0.5 µm
Curl radius, max	4 m

Table 5-1 The most common geometrical parameters for standard single-mode fiber 8–10/125 µm.

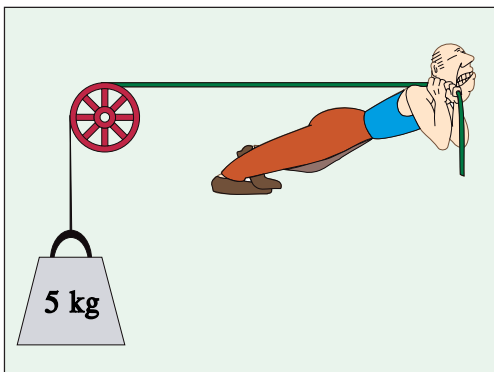

Fig. 5-5 Maximum permissible stresses on a primary coated fiber.

## Color-coding for optical fibers

To make it possible to identify different fibers during installation, they are color-coded in accordance with different national, international or de facto standards. Fibers can be colored either in a separate process or during the application of the buffer. When choosing the color, the following factors must be taken into consideration:

- The coloring agent (a color solvent or UV-curable ink) must not affect the fiber transmission capacity
- It must be durable
- It must remain unaffected by its chemical environment.

In the table below, the color-coding scheme used by Telia AB, Sweden is shown.

Fiber No.	Color	Fiber No.	Color
1	Red	7	Brown
2	Blue	8	Black
3	White	9	Orange
4	Green	10	Violet
5	Yellow	11	Pink
6	Gray	12	Turquoise

Table 5-2 Color-coding scheme used by Telia AB, Sweden.

## Recommendations for optical fiber

International standards and recommendations have been developed for the manufacture of optical fiber. There are currently two different types of standard: ITU and IEC. The following recommendations have been issued:

ITU Rec. G.650	Definitions and testing methods for single-mode fiber
ITU Rec. G.651	50/125 $\mu\text{m}$ graded-index multimode fiber
ITU Rec. G.652	Single-mode fiber
ITU Rec. G.653	Dispersion-shifted single-mode fiber
ITU Rec. G.654	Low loss single-mode fiber
ITU Rec. G.655	Non-zero dispersion shifted single-mode fiber
IEC 60793-1-1	Optical fibres: Generic specification - General
IEC 60793-1-2	Optical fibres: Measuring methods for dimensions
IEC 60793-1-3	Optical fibres: Measuring methods for mechanical characteristics
IEC 60793-1-4	Optical fibres: Measuring methods for transmission and optical characteristics
IEC 60793-1-5	Optical fibres: Measuring methods for environmental characteristics

## Second parameter, the buffers

The primary coated fiber can be used in some technical applications, such as printed board assemblies, without further protection. Normally an additional protecting layer - the buffer - is applied over the primary coating. Currently, three main methods are used:

- Loose tube buffer (loose fibers or ribbons in tube)
- Tight buffer
- Fiber ribbon

### Loose tube buffer (loose fibers/ribbons in tube)

To prevent changes in fiber optical properties due to pressure, tensile stress, bends, torsion and friction, the primary coated fiber or the ribbon is laid loosely in a narrow tube. The simplest variant is, of course, to have one fiber loose in a plastic tube. A somewhat more complex variant involves several fibers (up to 12) or ribbons loose in a plastic tube. Normally there are only 4-6 fibers/ribbons per tube. The tube must conform to the following requirements:

- It must not deform through normal mechanical load
- It must be durable
- It must withstand reasonably rough handling during installation without this changing the fiber optical properties.

The manufacture of loose tube buffered fibers/ribbons is a continuous process in which up to 25 km long tubes can be manufactured. The tube is extruded around 1-12 fibers/ribbons and simultaneously filled with thixotropic gel. The outer diameter of the tube can vary between 1.5 and 8 mm depending on the number of fibers/ribbons to be laid in the tube. The wall thickness varies also, and is normally between 0.3 and 1 mm. The thixotropic gel waterproofs the tube along its length. It also simplifies the production process. The tube itself is normally made of polyamide (PA-12 or nylon) or polybutyleneterephthalate (PBTP). Both of these plastics have very good physical properties that fulfil the requirements outlined above.

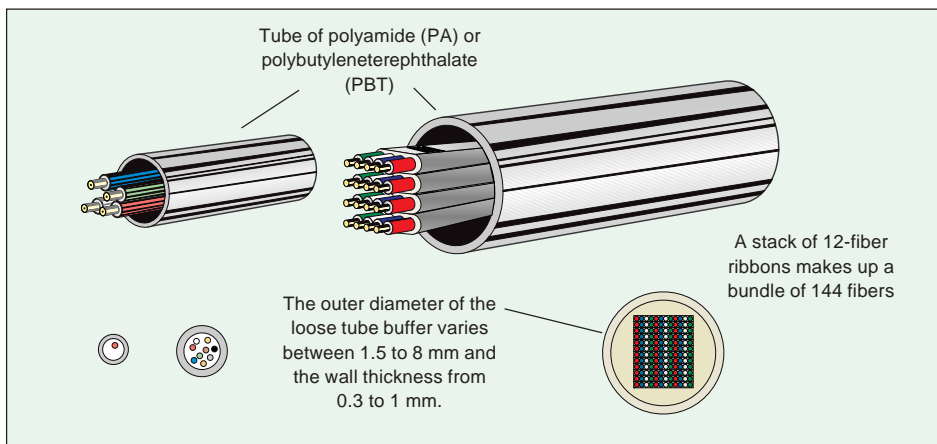

Fig. 5-6 A number of primary coated fibers or ribbons can lie loosely in a tube, which functions as a loose tube buffer.

The fibers are colored before extrusion. When the tube is located within the cable, the fibers in the tube are free to move radially inside the tube and thus compensate for tensile stress, pressure, torsion, bending and the effect of temperature variations (see Figure 5-7).

### Temperature variations

The glass of the fiber and the plastic that makes up the remainder of the cable differ greatly in their thermal expansion coefficients. The plastic in the cable has a large thermal expansion coefficient, which means that the cable will be longer in the summertime. The glass in the fiber has a very low thermal expansion coefficient and hardly expands at all. Because the glass fiber is free to move radially in the loose tube buffer, under normal circumstances this prevents stretching of the fiber. Under cold conditions, the reverse situation occurs, where the plastic in the cable shrinks.

Before being made into cable, the tubes may be color-coded in accordance with a standard or customer specifications.

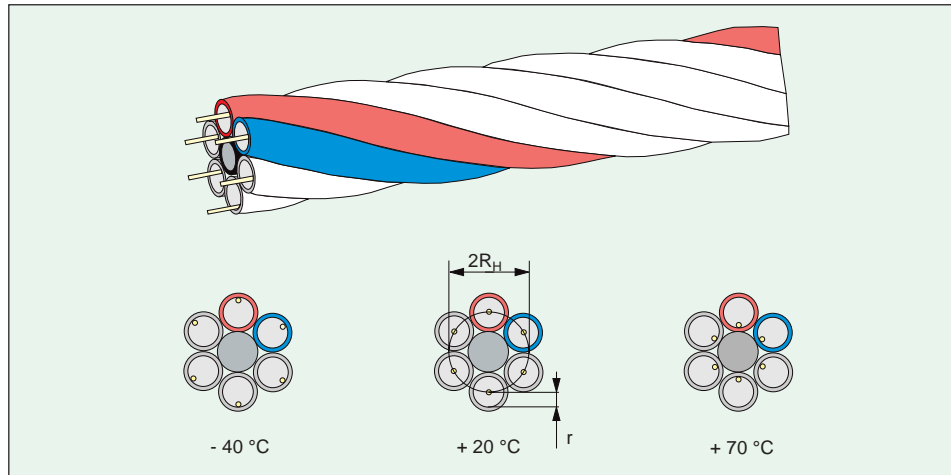

Fig. 5-7 The fibers can move freely within the loose tube buffer to compensate for temperature variations.

### Areas of application for loose tube buffered fibers

Cables containing fibers in tubes have a wide area of application. They have been used very successfully in all areas of information transfer. The relatively high/high packing density possible with this kind of cable has been utilized primarily in long distance networks in which, depending on application, 12 - 500 fibers per cable is common. For indoor applications, with less amount of fibers these cables are often used for trunk networks between computers, or for PABXs, or between various types of concentrators.

### Tight buffered fibers

The other alternative is to protect the primary coated fiber by applying a thick layer of plastic directly on the 245 - 500  $\mu\text{m}$  thick primary coated fiber.

A layer of PA-12 or PBTP is extruded at a temperature around 250°C. After extrusion, the fiber has a diameter of  $0.9 \pm 0.1$  mm. During the extrusion process, the finished fiber is also color-coded to make it easy to identify and handle during installation.

### Areas of application for tight buffered fibers

Cables that use fibers with a tight buffer have their greatest area of application indoors, as connector cables and rack cables. The advantages of fibers with a tight buffer are that they are relatively easy to deal with during installation (they are thicker - 900  $\mu\text{m}$  as opposed to 245  $\mu\text{m}$  - and much more robust) and that they can easily be terminated with a connector. Today, Local Area Networks (LAN) use almost exclusively tight buffered multi-mode fiber, but the trend of using multimode is likely to swing

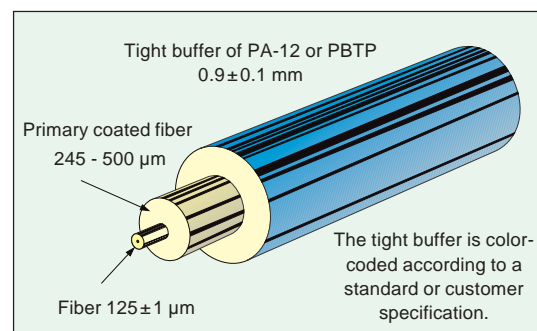

Fig. 5-8 Fiber with tight buffer.

towards single-mode when greater transmission capacity is required and as laser diodes (transmitters) become cheaper.

Long distance networks and other networks with loose tube buffered fibers are terminated with one to several meters of tight buffered fiber fused to the end (called pigtails). This is done to simplify the connection of long distance cable to racks. Note that in this case the fiber must be of the same type as the fiber in the network.

### Fiber ribbon technique

A third technique for adding the buffer is to lay several (in general 2 - 12) primary coated fibers side by side, and then applying the additional coating. This technique is not universally adopted. Today it is used mostly in Japan, USA, Italy, Sweden, Malaysia, the Philippines and a few other countries. It will therefore be described in more detail than the other two techniques discussed above.

Fiber ribbon is manufactured in three ways:

- Taping
- Edge bonding
- Encapsulating

### Encapsulating

This constitutes a development in the manufacture of fiber ribbon. The fibers are laid close together and a layer of acrylate is applied around the fibers (2-16 per ribbon). A thin layer of acrylate results in an encapsulated ribbon that is similar to fiber ribbon produced using edge bonding. A thicker layer of acrylate (in total with the fiber 0.4 mm thick) results in the fibers being encapsulated with a relatively effective buffer. This thicker layer provided added protection against mechanical forces. The acrylate layer makes the ribbon easier to handle during fusion or mechanical splicing, and cabling and installation.

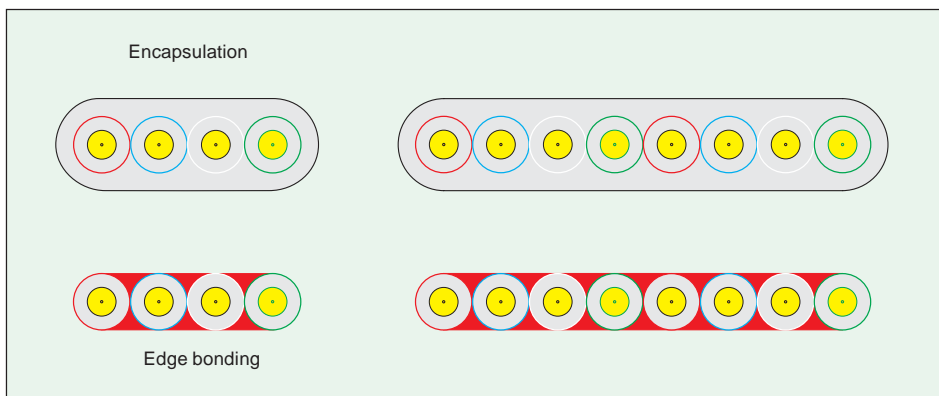

Fig. 5-9 The three most common methods of manufacturing fiber ribbon.

### Edge bonding

See Figure 5-9. In this method, acrylate is allowed to fill the gaps between two adjacent fibers. Up to 12 fibers can be laid parallel to each other in a fiber ribbon. The individual fibers are thus easier to prepare for fusion or mechanical splicing. The disadvantage of this method is that the fibers in a fiber ribbon are relatively vulnerable to mechanical damage.



## Encapsulated ribbon fiber

### Manufacture

Generally, colored primary coated fibers are used in the manufacture of fiber ribbon. It is preferable if fibers colored with UV-cured ink are used, since this type of coloring is less sensitive to mechanical damage. Bobbins with the variously colored fibers are set up on a separate stand from which the different fibers are brought together in an ingenious system of pulleys to form a ribbon of fibers lying parallel and in close proximity (see Figure 5-10). The parallel fibers pass a die which applies acrylate around the fibers so that they are bonded to each other. The acrylate is applied at increased pressure and at a temperature around (+35 °C). The high pressure prevents air bubbles forming between the fibers. The fiber ribbon is then irradiated with UV light to cure the acrylate. This layer encapsulates the fiber ribbon and gives it its final dimensions. The fiber ribbon is finally spooled onto a take up drum. The production speed is around 240 m/min.

### Color code for ribbons

The color code for ribbons may follow the color code for single primary coated fibers or the newly introduced code with lines printed on the surface of the ribbon matrix. One line is ribbon number one, two lines mark ribbon number two, and so on, see “Chapter 14, Tables” for detailed information.

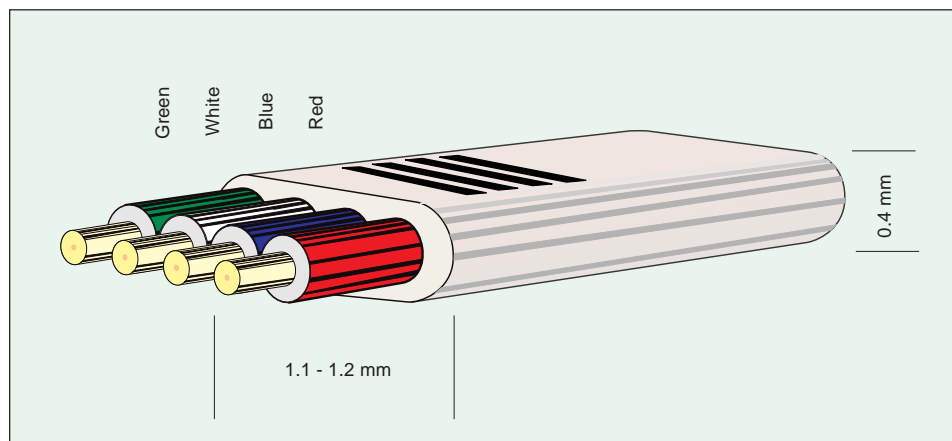

Fig. 5-10 Encapsulated fiber ribbon. The illustration shows a fiber ribbon with one layer of acrylate applied over primary coated fibers.

### Tests

The manufacture of fiber ribbon adds a significant number of technically complicated operations to what is already required for regular fiber manufacture. Ericsson Network Technologies in Hudiksvall is one of the large scale producers of fiber ribbon in Europe. Experience shows that great care in the production processes and a comprehensive testing program both in the production line and final testing produces a satisfactory final result.

The tests are categorized as:

- type testing
- process testing.

Type testing normally should be performed annually, or when a fundamental change has been made. Process testing is performed daily. Each of the major test methods are briefly described below.

The starting point for encapsulated ribbon is fiber that fulfils the IEC/ITU specifications. In addition, there are special requirements concerning the fiber dimensions, the acrylate used, and the fiber coloring. Dimension tolerances are somewhat closer, and the acrylate must have properties that will enable the finished ribbon to pass testing. The fiber must be colored with a UV-cured acrylate. It can be done off-line in a separate process or on-line in the ribbon process.

**Macrobend test**

The ribbon is coiled with a hundred turns around a 40 mm mandrel for the 1310 nm test, and around a 60 mm mandrel for the 1550 nm test (see Figure 5-11). To pass the test, attenuation changes must be negligible.

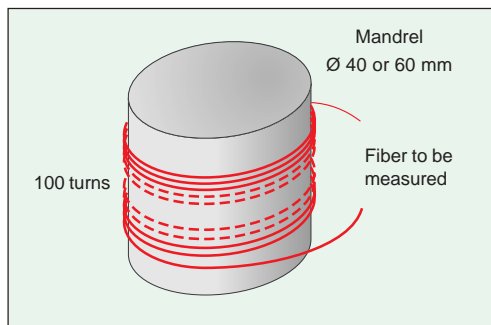

Fig. 5-11 Setup for macrobend test.

**Torsion test**

A 1 000 mm sample is fixed in a test rig as shown in Figure 5-12. The sample is twisted 2160° under a longitudinal load of 5N. To pass the test, attenuation change must be negligible.

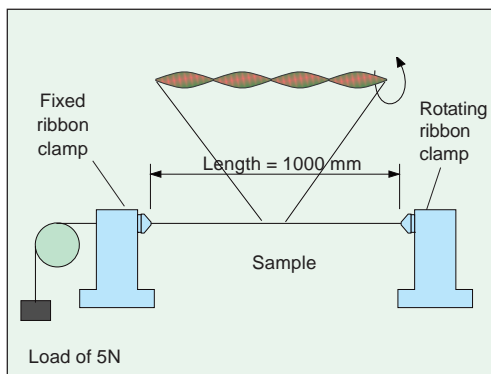

Fig. 5-12 Setup for torsion test.

**Crush test**

A sample of ribbon is placed between two plates and a load is applied to the upper plate, see Figure 5-13. The upper, smaller plate must have rounded edges, to avoid influencing the result. To pass the test, attenuation changes must be negligible.

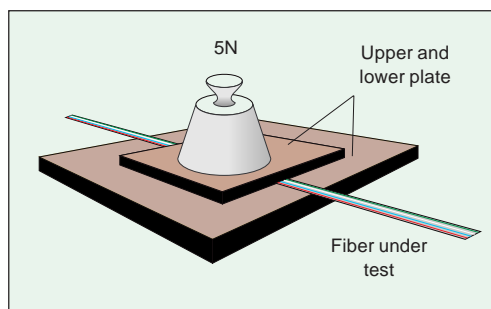

Fig.5-13 Setup for crush test.

**Environmental test - temperature cycling, heat and humidity**

A fiberoptic cable must tolerate the most diverse environments, e.g., winter in northern Scandinavia with temperatures down to -40°C; or desert landscapes with temperatures rising towards +70°C; or a combination of high temperatures and high humidity or rainfall in tropical rainforest. To assure the cable performance,

in these diverse environments, the ribbon is subjected to repeated temperature cycling from  $-40^{\circ}\text{C}$  to  $+70^{\circ}\text{C}$  in environments of varying humidity. To pass the test, attenuation changes must be insignificant.

### Compatibility with filling compound

For a cable to fulfil a requirement that, for example, it is waterproof along its length, filling compounds are used inside the cable sheath. There must be no migration of substances between the filling compound and the acrylate, nor may they affect each others properties, for the entire lifetime of the cable. The same applies to all the materials that go into the cable.

### Reliability testing

Normally, the guaranteed lifetime of a fiberoptic cable is 30-40 years. To be able to guarantee such a long life, continuous aging testing of both the primary coated fiber, the different types of buffered fiber (e.g., ribbon) and the complete cable are carried out. In recent times, great interest has been awakened for accelerated aging tests, which can reduce the time needed for type testing.

### Process testing

During the production of fiber ribbon, a large number of tests are carried out to assure the quality of the finished product. Many of these tests are carried out on all the fiber ribbon manufactured, and are thus an integral part of the production process. The remaining tests are performed on random samples of fiber ribbon.

### Strippability - random testing

As part of the preparation for fusion splicing, it is necessary to remove all the acrylate from a certain length of ribbon. A special stripping tool is used to strip the acrylate from the fibers, which are then washed in alcohol to remove all traces of acrylate, see Figure 5-14.

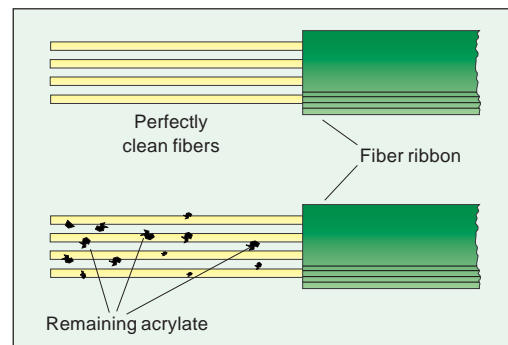

Fig. 5-14 Example of good strippability (upper) and bad strippability (lower).

### Separability - random testing

It must be possible to separate the fibers in a ribbon, for example, when the ribbon is to be spliced to a connector with a separate connection for each fiber. The fibers are separated by hand, and after separation the fibers' individual primary coatings (acrylate) and coloring must be intact, see Figure 5-15.

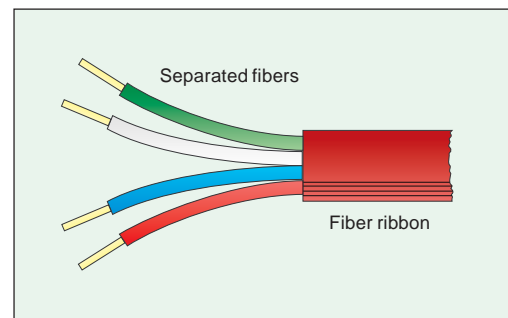

Fig.5-15 Each individual fiber must be able to separate without damage to the individual primary coatings.

### Fiber curl

Fiber curl is a longitudinal property of glass that each fiber has to some extent. When stripped, the bare glass may curl slightly, Figure 5-16, which can create problems during fusion splicing. The curl originates in the preform from which the fibers were drawn and the drawing process itself. Fiber curl can be measured easily under a microscope. In production, these measurements are performed routinely.

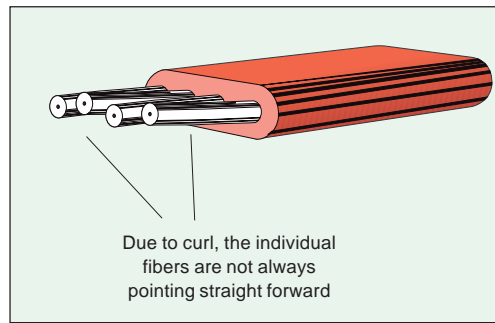

Fig.5-16 Fiber curl.

### Fusion splicing

The basic advantages of ribbon is that splicing and installation are faster and simpler with ribbon. However, ribbon is consequently more dependent on the quality of its ingoing components. If these advantages are to exist, it is essential that no problems with splicing arise. Normally, fiber ribbon is spliced, see Figure 5-17, in the production environment and splice loss and attenuation at 1550 nm are measured (see below).

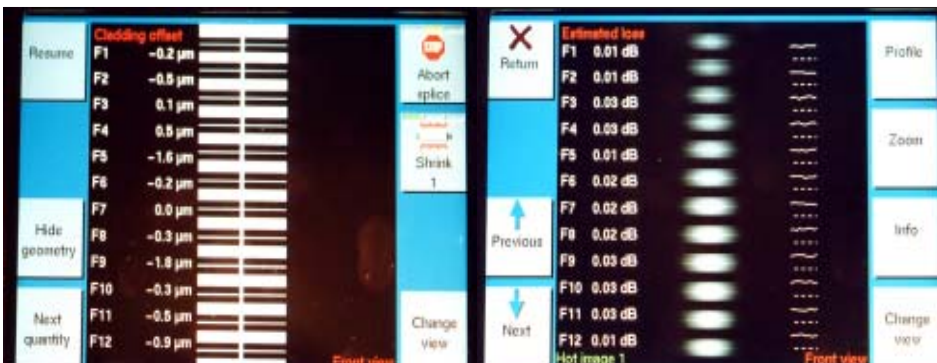

Fig. 5-17 Electronic pictures taken before and after splicing of a 12-fiber ribbon. Warm image and estimated loss. Fusion splicer, RSU12.

### Attenuation

This test should be scheduled as part of the process control. Investigations show that with a carefully performed process, it is not necessary to remeasure the transmission parameters of fiber ribbon. It is sufficient, as a quality control, to measure attenuation at 1550 nm with an OTDR. To pass the test, attenuation changes must be negligible.

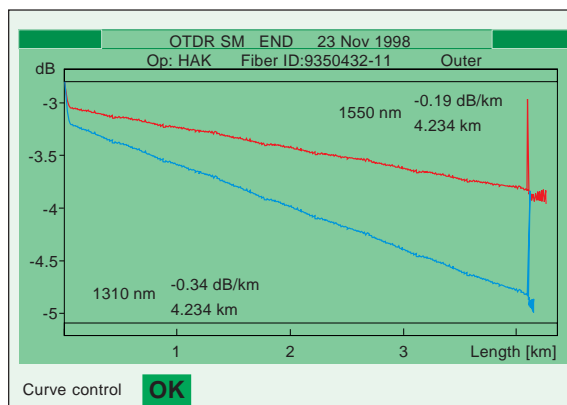

Fig. 5-18 Graphs showing OTDR attenuation plot at both 1310 nm and 1550 nm.

### Geometry

The geometric parameters of fiber ribbon (see Figure 5-19 and Table 5-3) are measured daily as part of the process control. Ribbon dimensions are not only important for splicing; they are also a measure of the consistency of the process. The following parameters have been measured and standardized in Sweden as of the end of 1993:

- a = fiber, including color layer
- b = center of outer fiber core to center of outer fiber core
- d = distance between adjacent fibers
- e = minimum thickness of matrix material around the ribbon
- h = height of ribbon, including matrix material
- p = planarity (worst case)
- w = width, including matrix material

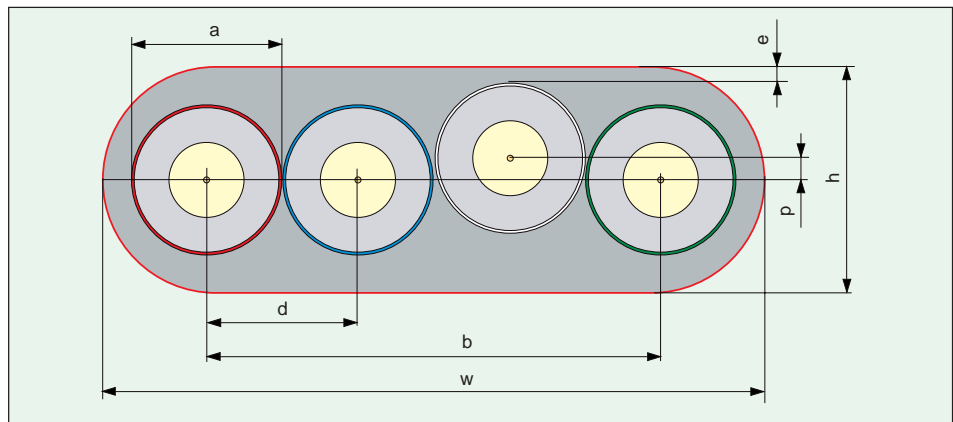

Fig. 5-19 Geometry of a four fiber ribbon.

Parameter	IEC Proposal	Swedish requirements
a [ $\mu\text{m}$ ]	$250 \pm 15$	$250 \pm 15$
b [ $\mu\text{m}$ ]	max 835	$760 \pm 30$
d [ $\mu\text{m}$ ]	max 280	max 280
e [ $\mu\text{m}$ ]	—	min 30
h [ $\mu\text{m}$ ]	max 480	$375 \pm 50$
p [ $\mu\text{m}$ ]	max 50	max 25
w [ $\mu\text{m}$ ]	max 1 220	$1\ 100 \pm 100$

Table 5-3 Parameters regarding the geometry of the fiber ribbon.

### Summary of fiber ribbon technology

The encapsulated ribbon technology has matured during the last five years. It is now a regularly used method in many countries. The advantages are obvious for higher fiber counts. The biggest benefit is in the field, but one example from the factory illustrates the situation. A 96 fiber cable test at the final inspection takes roughly 5 hours. With a fully automatic ribbon technique the same number of fibers can be measured in under 2 hours.

Color coding has hardly been discussed. For ribbons it is important to realize that with higher fiber counts it becomes very difficult to have colored matrix materials. The visualization disappears. Therefore all coding should be done with fiber coloring only and uncolored matrix material used.

## Third parameter, the strength member

As mentioned previously, the risk of fiber breakage increases when a fiber is subjected to strong longitudinal stresses in association with, for example, cable laying. All fiberoptic cables are therefore equipped with some form of strength member. The function of the strength member is primarily to prevent longitudinal deformation of the cable. For this reason, the strength member is made from materials that are stable through a range of temperatures and have a high elasticity modulus.

### Metallic strength member

A central steel wire or cord with a diameter of 2 - 3.5 mm is used as the inner core of the cable, around which 4 - 12 loose tube buffered fibers or fibers with tight buffering are laid concentrically and helically.

The metallic strength member can be placed, as an attachment, outside the fiber optic cable. The strength member and the cable will be joined in the final sheathing process thus forming a "Figure 8" type cable.

### Central non-metallic strength member

To obtain a completely metal-free cable, a fiberglass-reinforced plastic rod is used instead of the steel wire. This gives a somewhat less effective protection against tensile stress than steel wire. In the future, different types of composite material; for example, aramide fiber reinforced plastic, will probably be used as an alternative to steel wire.

### Aramide yarn

In cables which are to be used under conditions that require flexibility and strength, aramide yarn is normally used as the strength member. The aramide yarn is placed parallel to one or several fibers with tight buffer, to form a simple but strong strength member. Aramide yarn is exceptionally resistant to tensile forces and highly flexible, and thus provides excellent protection against longitudinal tensile stress. Aramide yarn is also used as extra reinforcement in aerial and duct cable. The yarn is wound as a layer around the body of the cable, or as a layer between the inner and outer sheath. Connecting cable (patch-cords), field cable and pigtailed are the most common areas of usage.

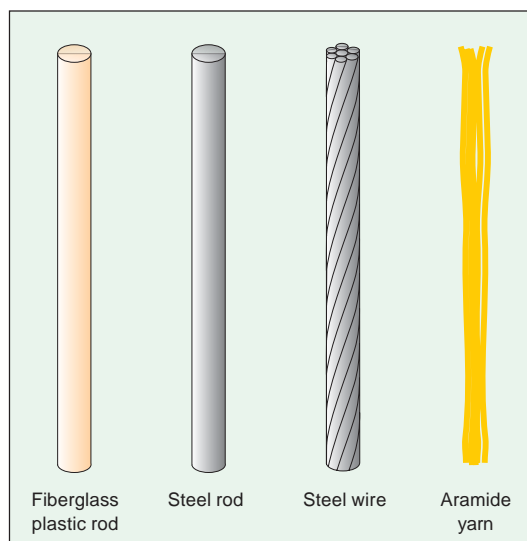

Fig. 5-20 Different types of strength member.

## Fourth parameter, the cable core

### Cables with circular core

The simplest form of core cable has a strength member as the core. These cables are generically termed concentric cables. Fibers, either in a loose tube buffer or with tight buffer, are laid around the strength member in a helical formation with a carefully calculated pitch. The pitch is calculated to counteract the attenuation variations in the cable; primarily due to the bending of the cable during manufacture, laying and installation, but also due to temperature changes.

Around the metallic or non-metallic strength member, 4 - 12 tight buffered fibers or loose tubes are normally laid, over which a thin layer of plastic film or yarn is applied to hold the fibers or tubes and cable core together. If the cable is to be laid outdoors, a filling compound is applied in the space between the loose tube buffers and the plastic film or yarn layer, to make the cable waterproof in the longitudinal direction. If the cable is to be used as an indoor/outdoor cable the filling compound can be substituted with a water swelling tape.

Finally, a protective sheath of plastic is extruded over the plastic film.

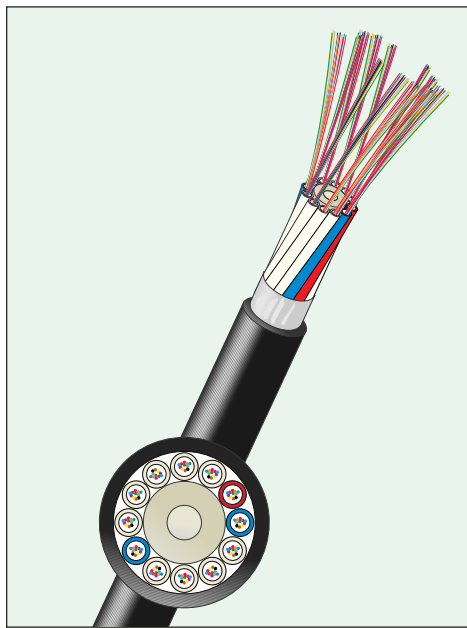

Fig. 5-21 Optical fiber cable, concentric construction, with loose tubes around the central strength member.  
Cable illustrated is the GRHLDV

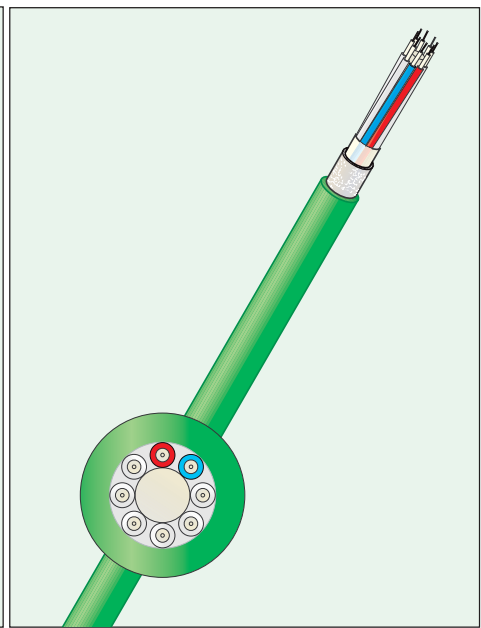

Fig. 5-22 Optical fiber cable; concentric construction with tight buffered fibers around the central strength member.  
Cable illustrated is the GNHLBDUV

## Cable with slotted core

For cables that will be continually subjected to radial forces during and after laying, special steps must be taken to protect the fibers. Several different types of cable core have been developed for this purpose. Most of them are based on the slotted core principle: optical fibers are laid in guide slots. Generally, a core profile of 3 - 12 slots is cast around a metallic or non-metallic strength member. The slots have either a helical (in either direction) or SZ-shaped pitch around the strength member. Slotted cores with a helical pitch have the same direction of rotation along the length of the cable, while slotted cores with an SZ pitch change the direction of rotation about the central axis. This means that the slots describe first an S-shaped curve, then - after a few rotations the helix reverses direction. The SZ core profile has simplified both the manufacture and installation of this type of optical fiber cable.

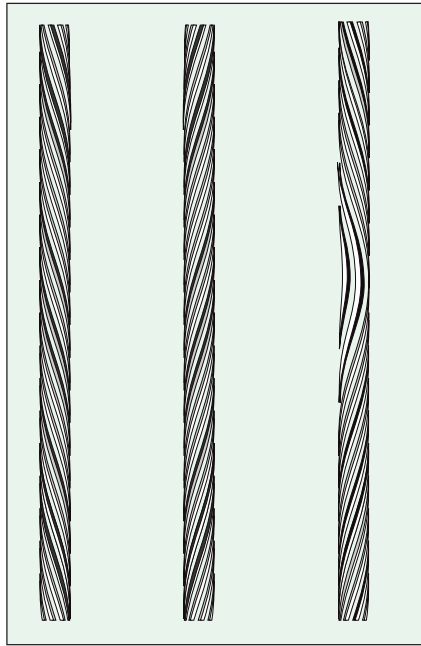

Fig. 5-23 Slotted core profiles. From left to right S, Z and SZ stranding.

All three types of profile are generally made of polyethylene (PE) plastic, but may also be made of polypropylene (PP). The profiles are extruded in lengths up

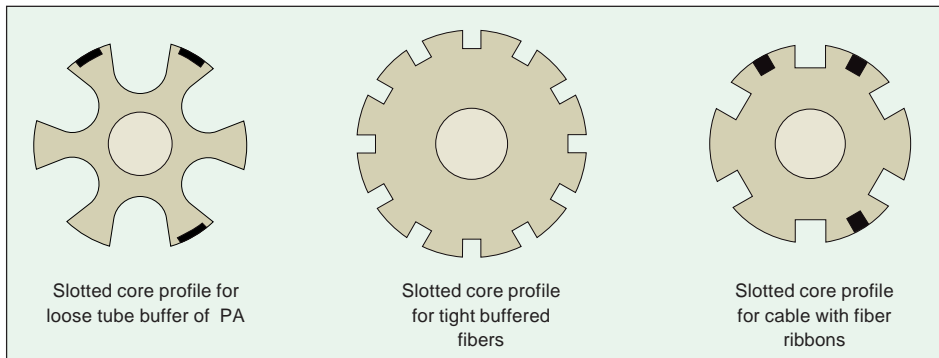

Fig. 5-24 Three different types of slot profile.

to 25 - 30 km, generally with a central strength member of steel or fiberglass-reinforced plastic. The profiles can have anything from 3 to 24 slots to accommodate 1 - 40 fibers in each slot.

## Manufacture

The slot profile is extruded over the strength member in a production line with a rotating extrusion die (S-profile) which determines the pitch of the slots. The SZ-profile is extruded on an oscillating FRP-rod. Fiber with tight buffer can be laid in the slots (normally 1 - 4 fibers per slot). Cables with tight buffered fibers are most



often used for indoor applications. For outdoor applications, each slot generally carries one loose tube buffer containing 2 - 12 primary coated fibers. In addition to the fibers, the loose tube buffers contain thixotropic gel as a longitudinally waterproofing agent. Cables with fiber ribbons may contain over 50 fibers per slot. A filling compound is applied around the loose tube buffers in the slots as further waterproofing. Figure 5-24 shows different types of slot profiles.

In the slotted core profile, the tubes are secured with yarn or plastic film. This is particularly important for an SZ profile.

### Pitch of a slotted core cable

For a helical pitch, the fibers form a spiral-shaped curve about the central axis, similar to that of a spiral staircase. The length of the slot after a full rotation of 360° is called L, while the cable length for the same distance is called the pitch length S. The angle between the fiber and the longitudinal axis of the cable is called the pitch angle  $\alpha$ . The distance between the fiber and the cable longitudinal axis is called the stranding radius R. The length of the fiber can then be calculated using the following formula:

$$L = S \sqrt{1 + \left(\frac{2\pi R}{S}\right)^2} \quad \text{Formula 5-1}$$

The pitch results in the cable having a certain fiber-over-length. This fiber over-length, Z, can easily be calculated using the following formula:

$$Z = \frac{L - S}{S} \times 100\% = \left\{ \sqrt{1 + \left(\frac{2\pi R}{S}\right)^2} - 1 \right\} \times 100\% \quad \text{Formula 5-2}$$

The helical curvature is three-dimensional. The fiber bend radius - r in the slots - can be calculated as:

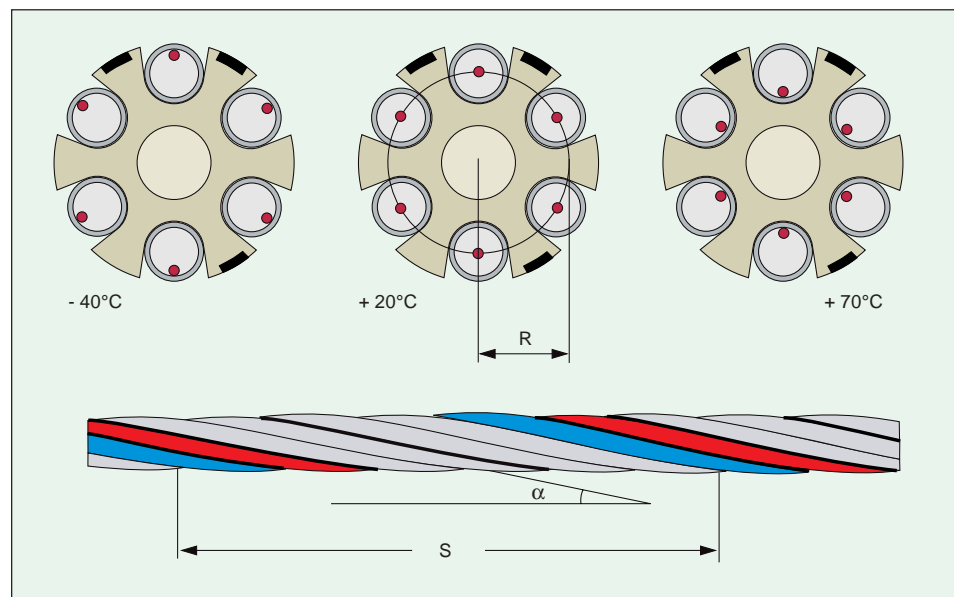

Fig. 5-25 Fibercreep due to temperature changes.

$$r = R \left[ 1 + \left( \frac{S}{2\pi R} \right)^2 \right] \quad \text{Formula 5-3}$$

It is important that the cable is not subjected to sharp bending during installation which could increase the tensile stress and thereby cause attenuation increase. The recommended value for maximum bending of the cable is normally 15 - 20 times the diameter of the cable. For all practical purposes, the above formulas can also be used, with some minor adjustments, for cable with an SZ pitch.

### Expansion and contraction of cables

Besides sharp bending, buffered fibers must be protected from lengthening and shortening (expansion and contraction) due primarily to temperature variations. As previously described, loose tube buffered fibers can move freely (within certain limits) inside the tube. In the normal state, without external forces acting on them, the fibers lie in the center of the tube. The fibers are thus free to move within an interval determined by  $R_{min}$  and  $R_{max}$  (see Figure 5-26). This interval is termed the expansion window and is designated by  $\epsilon_w$ .

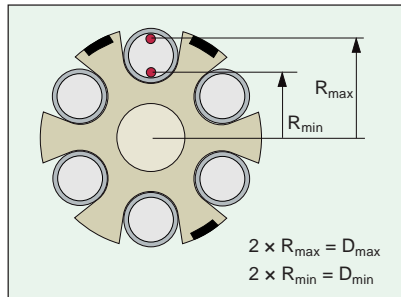

Fig. 5-26 The fiber can move freely between  $R_{max}$  and  $R_{min}$  in an optical fiber cable with a slot profile.

The expansion window can be calculated for a cable with a pitch length  $S$  and stranding radii  $R_{min}$  and  $R_{max}$  using the following approximative formula:

$$\epsilon_w = \pm 0.5 \left[ \sqrt{\frac{S^2 + \pi^2 (D_{max})^2}{S^2 + \pi^2 (D_{min})^2}} - 1 \right] \quad \text{Formula 5-4}$$

In this expression, a positive (+) value is used to describe the lengthening of the cable and a negative (-) value is used to describe its shortening.

#### Calculation example

The following are parameters for a common slotted core cable:

- $S = 135 \text{ mm}$
- $D_{max} = 8.85 \text{ mm}$
- $D_{min} = 7.15 \text{ mm}$

If these values are substituted in the formula given above, a maximum permissible lengthening/shortening of the cable - expressed as a percentage - is obtained as follows:

$$\epsilon_w = \pm 0.5 \left[ \sqrt{\frac{135^2 + \pi^2 (8.85)^2}{135^2 + \pi^2 (7.15)^2}} - 1 \right] \approx \pm 0.36\% \quad \text{Formula 5-5}$$

The cable can thus be permitted to lengthen or shorten by a maximum of 0.36 %.

## Expansion and contraction caused by temperature variations

As was mentioned previously, the cable must be capable of withstanding large temperature variations (normally in the range  $-40 - +70^{\circ}\text{C}$ ). Very low temperatures are especially problematic, since the thermal shortening of the cable occurs because the plastic material contracts to a greater extent than the fiber. This can cause microbends, resulting in increased attenuation. Table 4 shows the thermal expansion coefficients for the materials most commonly used in cable manufacture.

To calculate the maximum lengthening/shortening of the cable due to temperature variations, the cross-section area at A, the Young's modulus E, and the thermal expansion coefficient  $\alpha$  for each of the constituent materials must be known. Given these values, the combined thermal expansion  $\alpha_c$  for the cable can be calculated as follows:

$$\alpha_c = \frac{\sum_{i=1}^n \alpha_i \cdot E_i \cdot A_i}{\sum_{i=1}^n E_i \cdot A_i} \quad \text{Formula 5-6}$$

In calculating  $\alpha_c$ , it is sufficient that the calculation includes the strength member, slotted core profile, sheath and any reinforcing materials used. Other cable components contribute only insignificantly to cable lengthening/shortening.

Figure 5-26 illustrates what happens in a cable with loose tube buffered fibers when the temperature rises and falls between the extremes of  $-40$  and  $+70^{\circ}\text{C}$ . The migration of fiber caused by extreme cold may be fatal by itself; if not, the shortening of the cable body will cause microbends in the fibers. At too high temperatures, the lengthening of the cable body subjects the fibers to longitudinal tensile stress. A lengthening of the cable just under 1 % causes the fibers to migrate from the top to the bottom position in their tubes.

The lengthening of the cable is calculated using the following formula:

$$\varepsilon_T = \Delta T \cdot \alpha_c \quad \text{Formula 5-7}$$

Material	Young's modulus [N/mm <sup>2</sup> ]	Density [g/cm <sup>3</sup> ]	Thermal expansion coefficient [1/K]
Glass, optical fiber	72 500	2,20	$5.5 \times 10^{-7}$
PBTF	1 600	1,3	$1.5 \times 10^{-4}$
Polyamide, PA	1 700	1,06	$7.8 \times 10^{-5}$
Aramide yarn	100 000	1,45	$-2 \times 10^{-6}$
Glassfiber reinforced plastic (FRP)	5 - 6 000	2,1	$6.6 \times 10^{-6}$
Spring steel	200 000	7,8	$1.3 \times 10^{-5}$
LDPE	200 - 300	0,92	$1 - 2.5 \times 10^{-4}$
MDPE	400 - 700	0,93	$1 - 2.5 \times 10^{-4}$
HDPE	1 000	0,95	$1 - 2.5 \times 10^{-4}$
PVC, soft	60	1,3	$1.5 \times 10^{-4}$

Table 5-4 Young's modulus, density and coefficient of linear thermal expansion of various materials used in optical fiber cables.

### Calculation example

For a standard slotted core cable with the same dimensions as in the previous calculation example, the following parameters apply:

Polyethylene (PE) approx. 78 mm<sup>2</sup> E = 2.04 GPa  $\alpha = 126 \times 10^{-6}$

Polyamide (PA) approx. 22.6 mm<sup>2</sup> E = 2.43 GPa  $\alpha = 74 \times 10^{-6}$

FRP-rod Ø 4mm approx. 12.6 mm<sup>2</sup> E = 52.4 GPa  $\alpha = 6.6 \times 10^{-6}$

If these values are substituted in the formula from the previous page, a thermal expansion coefficient of  $3.26 \times 10^{-5}$  is obtained. The lengthening of the cable is calculated with the formulas above. For a temperature change of  $\pm 65^\circ\text{C}$  this will be:

$$\pm 65 \times 3.25 \times 10^{-5} = \pm 0.21 \%$$

which lies below the maximum previously calculated value of 0.36 %.

Thus, it can be stated that this cable passes the test for a temperature change of at least  $\pm 65^\circ\text{C}$ .

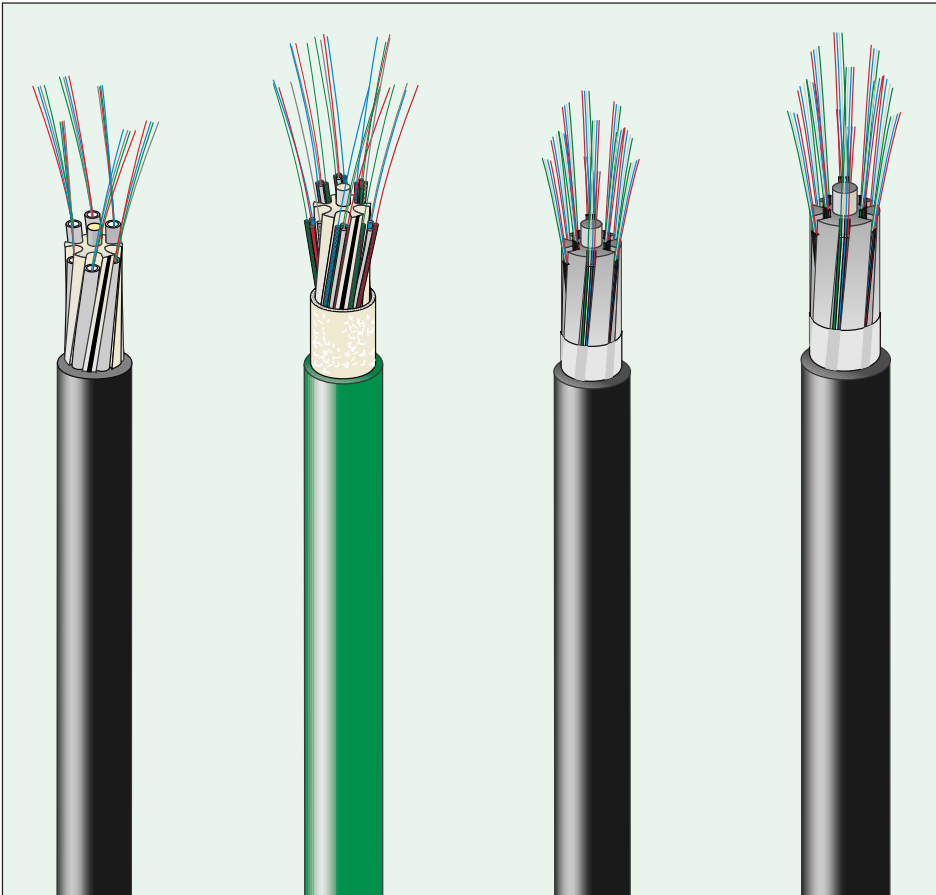

Fig. 5-27 Four examples of optical fiber cables with slotted core.

Cables illustrated are from the left:

GRSLDV, outdoor cable with loose tube buffer.

GNSLBDV, indoor/outdoor cable with tight buffered fibers

GASLDV, outdoor cable with four fiber ribbon

GASLDV, outdoor cable with eight fiber ribbon

## Optical fiber cable without a core

The simplest type of optical fiber cable consists of one or two single-mode or multimode fibers, often with tight buffer, covered with aramide yarn and a sheath of flame retardant PE or PVC plastic. This kind of cable is manufactured in several variants with one or two layers of aramide yarn, and one or two layers of plastic sheath. By using thermoplastic polyurethane elastomer (TPU) for this sheath, the cable can also be used in (military) field applications.

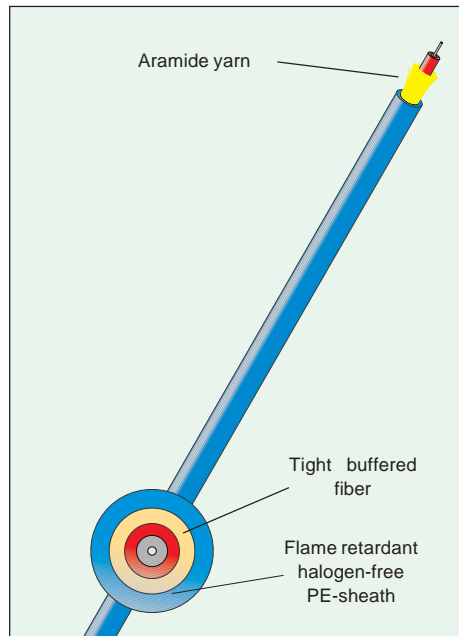

*Fig. 5-28 The simplest optical fiber cable design is suitable for connecting cables and in data networks. The cable illustrated is GNLBDU.*

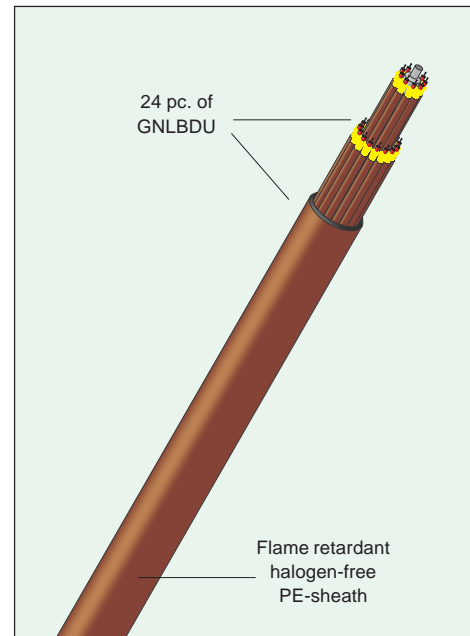

*Fig. 5-29 With a multiple of subcables and an extra sheath, this cable becomes a neat package of 24 GNLBD cables measuring only 15 mm in diameter. The cable illustrated is GNHLLBDU.*

## Fifth parameter, the water protection

Many cables are subject to situations where the sheath may be damaged. Outdoor cables in particular are subject to water and moisture that can penetrate the cable through the smallest defects in the sheath, or through a poorly made splice.

If water does penetrate an optical fiber cable with free space between the fibers or between the tubes that function as the buffer for the fibers, the water will follow the cable core or tubes until it reaches the lowest level, where it will collect. Water shortens the service life of the fibers by corroding the glass. There is also a risk that the resulting higher concentration of hydroxide will increase attenuation in the fibers.

### Filling compound

When the plastic tube is extruded over the fibers to form the loose tube buffer a thixotropic gel is applied inside the tube. This gel will function as a longitudinal water blocking compound. Water could migrate along the loose tube buffer tube for several hundred meters if no gel is used.

The most common way of avoiding water and moisture damage is to fill the space between the fibers, tubes, fiber ribbons and sheath with a moisture-rejecting filling compound. This filling compound must NOT affect the constituent plastics or fibers in the cable in any way. The filling compound prevents water and moisture from penetrating further along the cable (once it has penetrated the sheath) and thus limits the potential damage to the area around the sheath damage (caused, for example, by holes, excavation, etc). Often, a thin plastic film is applied over the filled cable body to improve the adherence of the final sheath to the cable body.

For indoor cables, this additional moisture-proofing is not necessary; these cables are sheathed “dry”.

### Water swelling tape

For indoor/outdoor cables a dry longitudinal water protection is commonly used. This is a tape that swells when it comes in contact with water. This swelling will prevent water from migrating along the cable. The "water swelling tape" has gained popularity as it makes installation in city networks much faster and easier as the time consuming cleaning of loose tubes and ribbons is avoided.

### Metallic foil

In cables that are subjected to high levels of moisture, water will diffuse through the plastic in the sheath, no matter how perfectly the cable sheath has been made and applied. To prevent the diffused water from reaching the cable interior, a layer of metallic foil (aluminium) may be laid around the cable before the sheath is applied.

### Metallic tube

#### Copper encapsulation

In cable to be permanently laid underwater, or in very wet ground, the cable body must be completely sealed within a layer of metal. In time, water diffuses through all common types of plastic material. The seal is a copper tube around the optical fiber cable identical to that for copper cable. A copper strip is formed into a tube and electrically welded, so that a completely water-proof tube seals the inner cable. The use of a metal tube is the only way to make an absolutely water-proof cable. One or several layers of steel wire (added weight and sometimes as protection against the anchors of pleasure boats) are then applied to submarine cable, and followed by layers of PP-yarn and anti-corrosive compound.

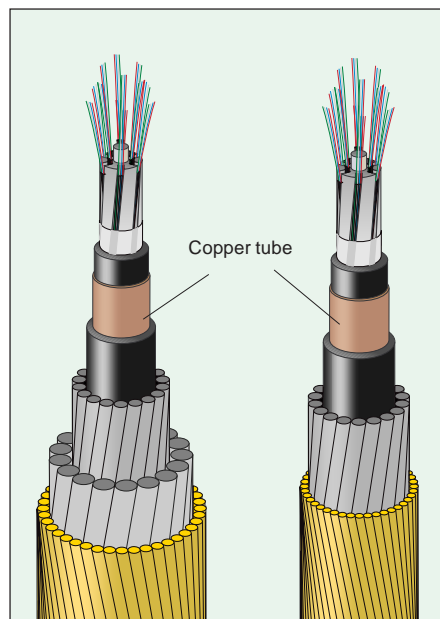

Fig. 5-30 Copper plate formed to a tube and electrically welded to a water-proof encapsulation.

Previously a lead tube was casted around the inner cable. Due to environmental and manufacturing reasons the lead tube is now replaced by an electrically welded copper tube. This tube must withstand the enormously high pressure obtained at the bottom of the sea.

#### **Note**

It is common practice that a thin plastic strip (identification tape) with the manufacturer's name and year of manufacture is placed under the plastic film for identification and determination of age.

## **Sixth parameter, sheathing**

### **Applying the final sheath**

This is the last process a cable passes through, before being used in the field. The sheath has primarily the following functions:

- Provides mechanical protection
- Provides thermal insulation
- Protects against chemicals
- Provides moisture protection
- Protects from rodents.

The technique used to apply the sheath to an optical fiber cable is identical to that used for applying the sheath to conventional copper cable.

The sheath consists of one or two layers of plastic material with or without a moisture barrier of aluminium foil or plastic film. The plastic materials normally used for the sheath are:

- Standard polyethylene (PE)
- Flame retardant halogen-free materials
- Polyvinyl chloride (PVC)
- Polyamide (PA)
- Fluoroplastics
- Polyurethane (PU)
- Copper tube (Cu)

The plastic materials used have different thermal, mechanical and electrical properties. Durability, resistance to chemicals, flammability, and the effects of contact with other materials also vary.

Thus, the choice of the right material for each specific product is a very important part of the standardization work that is carried out in co-operation between government authorities, manufacturers, and users.

## **Polyethylene (PE)**

Low Density PE (LDPE) or Low Linear Density PE (LLDPE) is commonly used for cable manufacture. However, the harder grades - Medium Density and High Density PE are also being used for their greater strength and resistance to deformation at high temperatures (see Table 5-4).

### **Thermal properties**

Because of the material thermal properties, the highest recommended continuous operating temperature is 60 - 70°C, while a short period of heating to 90°C is tolerated on condition that the cable is not simultaneously subjected to pressure. The melting point of PE is approximately 110-130°C. Like other thermoplastics, PE becomes more rigid when exposed to cold but becomes brittle only at temperatures around -65°C.

### **Mechanical properties**

The mechanical properties of PE are good. Its breaking strain at 20°C is at least 10 MPa. Insulation PE can be stretched 400 % before it breaks, and PE for cable sheaths can be stretched 500 % and has a breaking strain of at least 12 MPa.

### **Ageing resistance**

PE is very ageing resistant and has a practically unlimited life, when used indoors and not subjected to direct sunlight. UV radiation, however, causes the formation of cracks in the material if a UV stabilizer is not present in the PE. The most commonly used UV-stabilizer is carbon-black. Weather resistant PE for outdoor use is therefore usually colored black.

### **Resistance to chemicals**

At room temperature, PE is very resistant to most chemicals, oils and other solvents.

### **Permeability**

PE has a very low moisture permeability. This means that PE as the sheath material provides excellent protection against moisture for cable to be used in moist or wet conditions.

### **Effect on other materials**

PE does not contain any plasticizer and therefore does not affect other materials through plasticizer migration. In contact with PVC, rubber, etc, PE can, however, absorb small amounts of plasticizer. In certain cases, PE should therefore only be used in contact with migration-free PVC, or should be protected by some other means against plasticizer migration.

### **Flammability**

PE is flammable. Additives can be used to improve the fire-resistance of PE, see under "Flame retardant halogen free materials".

## **Halogen-free, flame-retardant materials (HFFR)**

Cables that are required to be both halogen-free and flame-retardant (different types of fire-resistant cable) must be specially manufactured. For the sheath material, PE, PVC or fluoroplastics are not normally acceptable. The sheath material of "fireproof" cables has to be based on polyolefins with a high degree of fillers.



One commonly used halogen free flame retardant filler is aluminium trihydroxide ( $\text{Al}(\text{OH})_3$ ).

At temperatures slightly above  $200^\circ\text{C}$ , water vapor forms due to the reduction of the aluminium trihydroxide. This reduction process lowers the temperature to below the flash point while the water produced tends to extinguish the fire. Water vapor also reduces the concentration of combustible gases. The end result is the flame-retardant material aluminium oxide ( $\text{Al}_2\text{O}_3$ ). The thermal and mechanical properties and resistance to chemicals of these materials are dependant on the polymer base and degree of fillers.

The major environmental and health advantages with these materials, is the substitution of the halogens by halogen free flame-retardants. HFFR cables are known to be environmentally friendly. The qualities used should be 100% halogen, lead and cadmium free.

## **Polyvinyl chloride (PVC)**

PVC is a mixture of polyvinyl chloride, plasticizer, stabilizer and other materials that can vary in type and grade. PVC can be given different properties for different purposes.

### **Thermal properties**

PVC is a thermoplastic material, i.e., it softens when heated and stiffens when cooled. Its softness at different temperatures is largely dependent on the type and amount of plasticizer in the PVC. Because of the material rigidity at low temperatures, it is recommended that the laying temperature be no lower than  $-10^\circ\text{C}$ . Unless otherwise specified, PVC-insulated cables can be used in ambient temperatures of up to  $+70^\circ\text{C}$ . In installations with high operating temperature, precautions should be taken so that the cable will not be subjected to constant high pressure at points where it runs over sharp edges, etc. At temperatures around  $100^\circ\text{C}$  for extended periods of time, standard grade PVC will become rigid due to the evaporation of plasticizer from the material. Special compounds like PVC 105, which is approved by SEMKO for continuous usage at  $+105^\circ\text{C}$ , contain less volatile plasticizers and thus retains their pliability for a longer period.

### **Mechanical properties**

PVC has very good tensile strength and tear resistance. The hardness of the material can be made to suit the area of application through the use of different types and quantities of plasticizer.

### **Ageing resistance**

PVC is very ageing resistant and has a practically unlimited life when used indoors. For outdoor use, black PVC is the most suitable, but a light-colored PVC can also be mixed so as to provide good weather-resistance. PVC is highly resistant to ozone.

### **Resistance to chemicals**

PVC is highly resistant to acids and alkalis, and to motor oil and a large number of solvents. Some solvents and oils can, however, extract the plasticizer from the PVC, making it harder. Resistance to these oils and solvents can be improved by the use of special, less extractable plasticizers in the PVC.

### **Effect on other materials**

Through plasticizer migration, after prolonged periods of contact with lacquered surfaces or other plastic materials, PVC can make these surfaces sticky and cause other changes to them. Cellulose-based lacquers and polystyrene are particularly affected, while thermosetting plastics and baking enameled surfaces are less vulnerable to these effects. PVC generally hardens somewhat in contact with materials to which plasticizers migrate.

### **Flammability**

Pure, rigid PVC contains 57 % chemically bound chlorine, which makes the material difficult to burn. Chlorine (as hydrochloric acid) in the combustion gases decreases the combustion process.

The PVC utilized in cables and flexible cords must be softened by the addition of different materials, which in many cases are flammable and reduce the PVC self-extinguishing capability, particularly at high ambient temperatures. By adding a variety of fire-retardant chemicals, this capability can be significantly improved - even in the case of standard PVC, and even at high temperatures. However, one must be careful not to overdose the material with these chemicals, if the resultant PVC is to fulfil standard mechanical requirements.

The self-extinguishing capability of PVC can be established through laboratory measurements of its oxygen index and self-ignition temperature, and through the use of simple fire tests. However, to fully evaluate the degree of flammability of a cable design, a well-defined fire test of the complete cable is required.

### **Polyamide (PA, Nylon)**

Polyamide is used primarily as a protective covering over PE or PVC sheaths on cables that will be subjected to significant mechanical stress (such as termites and small rodents) or chemicals. PA is also used as buffer for optical fibers. Several different variants of PA are used in the manufacture of optical fiber cable, utilizing the different features of the material. PA 12 is used as a buffer for optical fibers, while PA 6 is used only as a mechanical protection.

### **Thermal properties**

PA can be used within a large temperature range, and remains viable under continuous operating temperatures up to +90°C. It softens at around 150°C and remains flexible down to -40°C.

### **Mechanical properties**

Compared to PVC and PE, PA is a very strong, resistant material. PA has a tensile strength of around 50 MPa at +20°C. PA can be stretched at least by 100 % before breaking.

### **Ageing resistance**

PA is very ageing resistant and has good weather resistance characteristics.

### **Resistance to chemicals**

PA is highly resistant to most oils and chemicals.

### **Effect on other materials**

PA does not contain any plasticizer, so plasticizer migration to other materials is not a problem. PA is not affected by contact with PVC.

## **Polybutylene terephthalate (PBT)**

Polybutylene terephthalate (PBT) is used as a secondary coating for optical fibers in a similar way to polyamide 12. PBT is a semicrystalline thermoplastic polyester with excellent mechanical and physical properties. PBT has high mechanical strength, a high heat deflection temperature, low moisture absorption, a good dimensional stability, excellent electrical properties and excellent chemical resistance.

### **Thermal properties**

Polybutylene terephthalate can be used within a large temperature range. It has a melting point at about 225 °C and a glass transition temperature range from 40 – 60 °C. The highest recommended service temperature of PBT lies between 120 and 140 °C. It can be used at temperatures low as –40 °C.

### **Mechanical properties**

The modulus of elasticity is 2.6 GPa which makes it more rigid than PA 12, which has a modulus of elasticity of about 1.4 GPa. The elongation is at least 100% and the strength is at least 40 MPa. The good mechanical properties enhance the protection given to the optical fibers.

### **Ageing resistance**

PBT offers a good resistance to ageing. In addition to optical cable applications it is often used in PC-keyboards and automotive exterior parts. Like all polyesters PBT is sensitive to hydrolysis which may manifest itself as a premature embrittlement and loss of tensile properties under certain conditions. Ericsson Cables AB uses a grade with improved hydrolysis resistance.

### **Resistance to chemicals**

PBT is resistant to most chemicals such as filling compounds, aliphatic hydrocarbons, oils, greases and solvents.

### **Effect on other materials**

PBT contains very few additives and it does not affect any other material.

## **Fluoroplastics (PTFE, FEP, E-TFE, E-CTFE)**

A number of thermoplastic materials that contain the halogens, fluorine and chlorine in varying concentrations are also used as sheath material for optical fiber cable. The mechanical properties of these materials are very good, which permits smaller dimensions of the products. The thermal properties of fluoroplastics, and their durability and resistance to ageing, oils, fire, and chemicals, are also very good, which means that they can be used within a very wide temperature range and in environments where other insulation materials cannot be used.

## **Thermoplastic polyurethane elastomer**

Like PA, polyurethane or thermoplastic polyurethane elastomer (TPU) is relatively expensive and therefore a less commonly used material in the manufacture of cable. It has excellent mechanical properties such as a high tensile strength (30 - 55 MPa) and is capable of withstanding a strain of 400 - 700 % before breaking. TPU's excellent abrasion resistance makes it particularly suitable as sheath ma-

terial for cables that require this feature, such as military field cables and cables in the moving parts of machines. Polyurethane also remains very flexible at temperatures down to  $-40^{\circ}\text{C}$  and has good resistance to oil, petroleum, and most solvents, as well as oxygen and ozone. TPU does not contain a plasticizer, and thus does not affect other materials through plasticizer migration.

## Seventh parameter, extra reinforcement

Normally, optical fiber cable is not supplied with any additional reinforcement over and above that described in the previous sections. Sheathed cable can be used for all types of indoor applications, and for outdoor applications in ducts or conduits. Because of its relatively low weight and small dimensions, optical fiber cable can be ploughed directly into the ground, or suspended between poles a variety of distances apart.

Cable for such applications must be supplied with some form of reinforcement. A major advantage of optical fiber cable is that it can be supplied with non-metallic reinforcement, so that an entirely non-metallic cable is obtained. Reinforcement comes in different forms, such as:

- Corrugated steel tape
- Steel wire
- Steel tape (band)
- Copper or aluminium encapsulation (submarine cable)
- HET (heat expandable tape) with HDPE sheath
- Fiberglass (when suspended over large spans)
- Aramide yarn
- Suspension strand.

### Corrugated steel tape

Adding a layer of corrugated steel tape and a second layer of polyethylene sheath produces a cable that can be directly buried in light terrain. These cables are also suitable for use in ducts as the reinforcement protects the inner cable from rodents, ants and termites. A cable with corrugated steel tape as reinforcement is also more flexible and easier to install than steel wire reinforced cable.

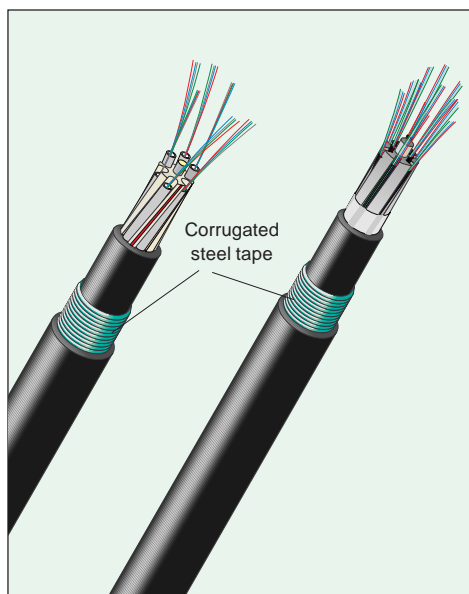

*Fig. 5-31 Corrugated steel tape-reinforced cable for laying underground, or in ducts. The cables illustrated are GRSLWLV and GASLWLV.*

### Steel wire, steel tape

Steel wire or band is laid in a spiral around the inner sheath. The second sheath can be made of HD-polyethene forming a very rugged cable. The advantage of this type of reinforcement is that the cable thus reinforced may be subjected to large radial and longitudinal forces.

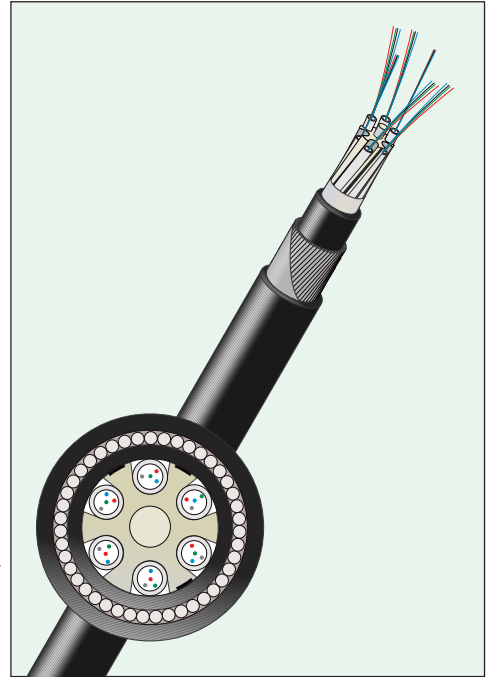

*Fig. 5-32 Steel-reinforced cable for laying underground, e.g., by direct ploughing.*

*The cable illustrated is GRSLTLV.*

### HET - heat expandable tape

A new method of increasing the resistance of the optical fiber cable to primarily radial stresses has been developed by Ericsson Cables. The technique is based on a heat expandable tape (HET). By winding a layer of HET longitudinally around the first sheath, and then applying a second sheath on top of the tape, the heat of the extrusion of the second sheath causes the tape to expand, forming an embedded expanded layer which acts as a protective cushion against radial stresses.

The tape consists of a non-woven bearing layer of polyester, on which there is a layer of microscopically small polymer bubbles containing isobutane. At a temperature between 90 and 120°C, the bubbles expand as the gas expands. HET expands to 3 - 4 times its original thickness and forms a soft layer between the two plastic sheaths. With this method, it is possible to manufacture fully dielectric cable for direct ploughing or laying underground.

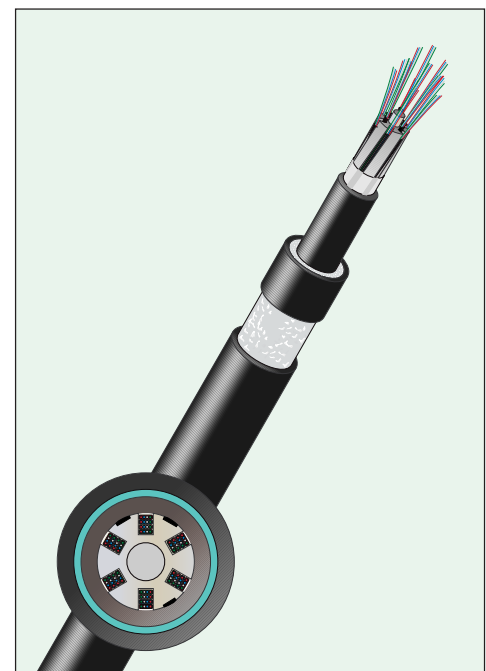

*Fig. 5-33 By using dielectric reinforcement, a completely metal-free cable can be manufactured for direct ploughing or laying underground. This cable is ideal for installations located in the vicinity of high voltage lines.*

*The cable illustrated is GASLLDV, 192 fibers.*

## Aramide yarn

As described in the sections above, aramide yarn can be used as reinforcement for the simplest types of optical fiber cable. For thicker cable with diameters 8 - 15 mm, aramide yarn can be applied as a layer or as segregated members between the first and second sheaths to strengthen the cable. The cable is then capable of withstanding large longitudinal forces. Normally this type of reinforcement is used for aerial cable (spans varying from 75, 150, 250 and up to 1 000 m).

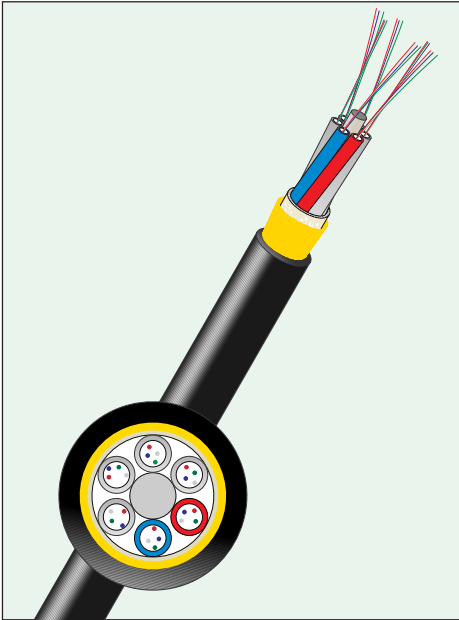

Fig. 5-34 Aramide yarn is used as longitudinal reinforcement in aerial cable for spans up to 250 m. The cable illustrated is GRLSDV.

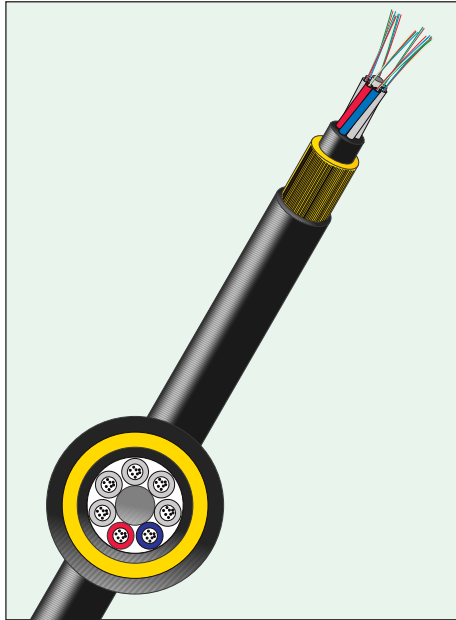

Fig. 5-35 Aerial cable with a large amount of of aramide yarn as strength member. This type of cable is self supporting for spans up to 1 000 m. Cable illustrated is the Skyspan™ (Focas Inc.).

## Suspension strands

A proven copper-cable technique is to cast a steel wire into the sheath, normally in a figure-8 profile (see Figure 5-36). Slotted core cable with loose tube buffered fibers or slotted core cable with fiber ribbon utilize this technique. Spans of 50 - 70 m are common.

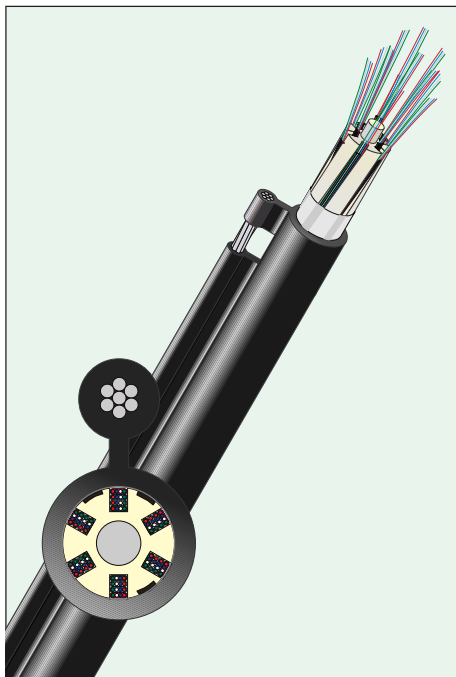

Fig. 5-36 With a steel suspension strand, optical fiber cable can be suspended in spans of 50 - 70 m. The cable illustrated is GASLCV.

## Optical ground wire, OPGW

OPGW is a replacement ground or shield wire containing optical fibers, and would normally be used for new or refurbished power line construction.

The central aluminium alloy core has two, three or four helical grooves running along its length into which are laid buffer tubes containing up to 12 optical fibers. The tubes are sealed into the helical grooves by a UV-cured silicone rubber.

Around this central optical core, aluminium or aluminium clad steel wires are applied to provide strength and conductivity

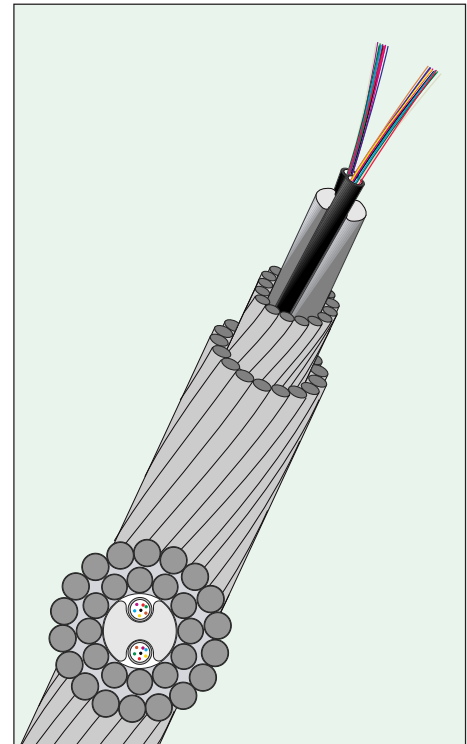
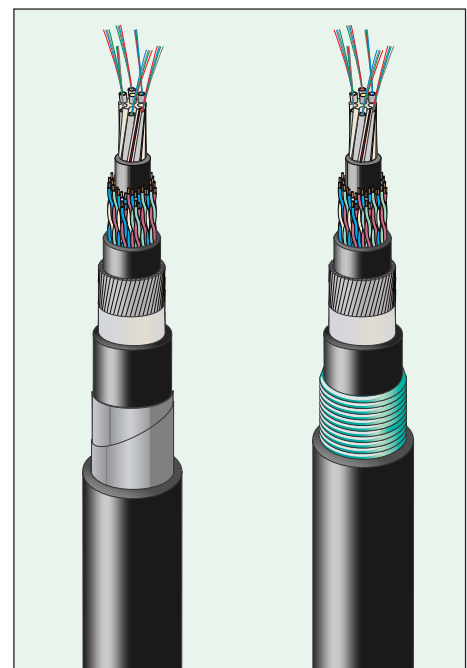

*Fig. 5-37 Optical power ground wire to replace the traditional ground wire on top of power lines. Cable illustrated is the Skylite™ (Focas Inc.).*

## Hybrid cables,

Many installations call for a combination of traditional copper cable and optical fiber cable. The copper cable will support a signalling systems as well as a low frequency telephone systems. The optical fiber cable is normally used for high capacity infocom systems. A typical field for hybrid cable is for railway installations. For communication between major stations the optical fiber cable is used. Signalling, communication to and from the locomotive, barrier lowering and security systems along the track between stations utilize the copper cable.

A cable that fulfils these requirements is shown in Figure 5-38. The optical fiber cable in the center is surrounded by a number of copper pairs. Reinforcement with steel wires and steel tape makes the cable very strong and durable.



*Fig. 5-38 Two examples of hybride cable designed to be installed alongside the railway tracks.*

## A collection of newer types of cables



Fig. 5-39 Cable to be wrapped around ground wire or phase line "Skywrap"

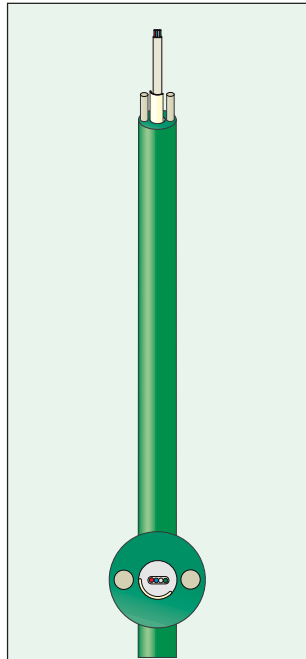

Fig. 5-40 Indoor cable with fiber ribbon, suited for FTTH etc.

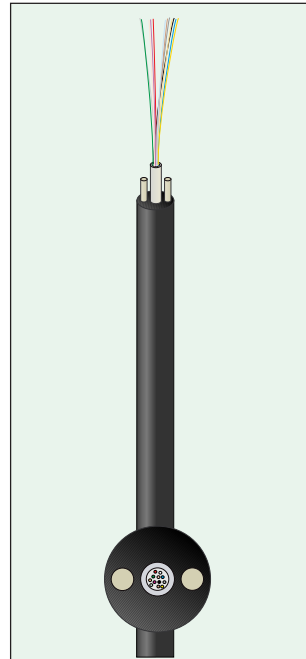

Fig. 5-41 Outdoor cable with loose tube suited for FTTH etc.

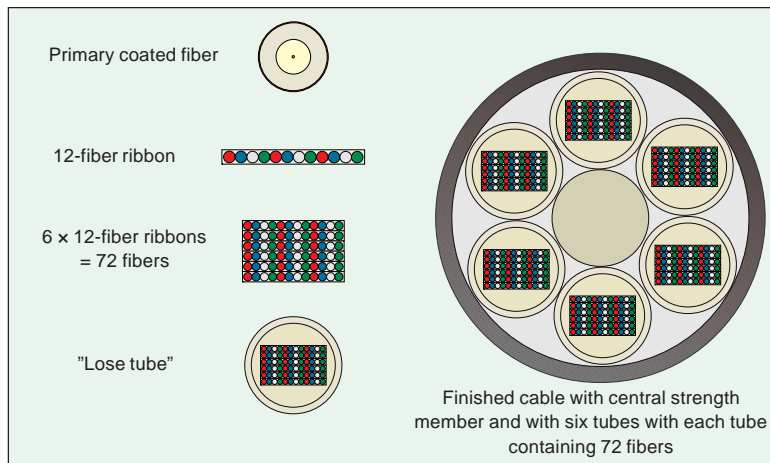

Fig. 5-42 Ribbon cable with 432 fibers

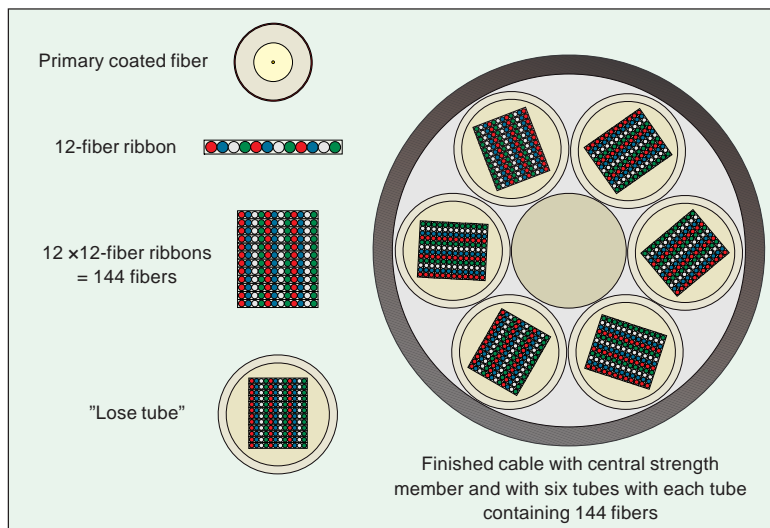

Fig. 5-43 Ribbon cable with 864 fibers



## Summary

1984/85 was the start for manufacturing and installing optical fiber cables in large scale. The first years saw very rugged cable constructions with both steel wires and steel band to physically reinforce the cable and the average number of fibers were less than twenty. Today the cable construction is without reinforcement or just lightly reinforced. Duct and aerial installation are the two most common methods for installation. The average fiber count is over 100 fibers per cable. Ribbon fibers is becoming more and more obvious due to rapid installation. Cables with more than 500 fibers are today a reality in metropolitan transport and community access networks. Figure 5-42 and 5-43 show a couple of high fiber count cable designs.



## Chapter 6

# Lasers and light emitting diodes for information systems

---

In this chapter, we examine the sources of optical radiation used in fiber optic information systems. A presentation of laser diodes in general, including their development and areas of application, is given by way of an introduction to this area. Following this is a description of the physical processes in the nucleus of an atom that make it possible to produce optical radiation. Semiconducting materials and their function are also described. Finally, the last part of the chapter describes the various opto-electrical components (OE components) used as light sources in a fiber optic information system.

The light source is often viewed as the active component in a fiber optic communications system. Its basic function is to convert electric energy (current) into optical energy (light) in such a way that the light can be efficiently transferred to an optical fiber to transmit information through the fiber over long or short distances. There are three types of light source:

- Broadband light sources with a continuous spectrum (lamps)
- Monochromatic, non-coherent light sources – light emitting diodes (LED)
- Monochromatic, coherent light sources – laser diodes (LD).



*Fig. 6-1 Modern He-Ne laser manufactured by Melles Griot.  
(Photo, courtesy of Melles Griot).*

In the early days of fiber optics (1965 - 1970), narrow band, coherent light sources were used. The main light source was a Helium-Neon (He-Ne) gas laser, with high output power to compensate for the high attenuation of the early optical fibers. Today, with the sharp reductions in attenuation in modern fibers, and developments in semiconductor technology that have made alternative light sources available (laser diodes and light emitting diodes), gas lasers have been replaced entirely.

The requirements for light sources for fiber optic communication in telecom and information networks are fully met by laser diodes and LEDs. These requirements are:

- the size and physical design of the diodes should be suitable for transferring light to an optical fiber, and the light should preferably be sharply directed
- the optical signal should be an accurate replica of the electric signal to minimize distortion and noise
- the emitted light must have a wavelength that corresponds to the fiber's lowest attenuation and dispersion. Further, the wavelength of the light must correspond to the maximum sensitivity of the detector
- the diodes must allow single modulation over a broad bandwidth, ranging from speech frequencies (a couple of Hz) to tens of GHz
- the diodes must transfer the main part of the emitted power to the fiber so that - in spite of losses in the fiber, connectors, splices, etc. - sufficient power is left to drive the detector at the other end of the system
- the diodes must have a very narrow spectral bandwidth to reduce dispersion in the fiber
- the diodes must have a constant optical output power, irrespective of the ambient temperature
- the diodes must be relatively inexpensive to be able to compete with existing (traditional) transmission technology.

The first optical systems included light sources for wavelengths around 850 nm, because the combinations of materials in the first laser diodes were such that they lased at this wavelength. The fiber was of multimode, step index type and the transmission distance was relatively short. In today's telecommunications systems, lasers for the wavelength range 1300 - 1550 nm and fiber of single-mode, step index type are used. With special fiber and power boosters with erbium-doped fibers, the transmission distance can be very long between optical amplifiers – today, up to 300 km (depending to some extent on the bit rate).

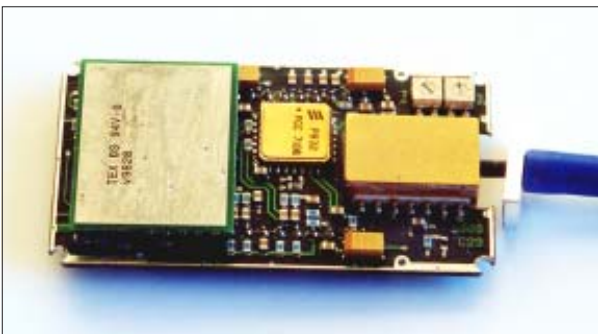

Fig. 6-2 STM-1 module with laser chip for 155 Mbit/s bitrate.

## About laser diodes

The first laser diode based on semiconductor technology was demonstrated in 1962, but it was not until the 1980s that this type of laser with associated technology came into general use. The almost explosive developments in laser technology were due primarily to two factors: the availability of new technology to produce better, smaller and cheaper semiconductor lasers, and the large number of areas of application that have been identified in recent years.

Developments in semiconductor technology have been nothing short of dramatic, and have resulted in smaller, but more complex components with markedly improved reliability and increased service life. It has been possible to develop laser diodes for longer or shorter wavelengths, higher output power, more well controlled optical radiation and longer life. Alongside this development, there has been a dramatic increase in the number of applications for the laser diode. Telecommunications and digital optical storage and playback (CD players) are probably the best known areas in which the laser diode has benefited the community in general.

Laser diodes have all the advantages associated with other semiconductors. They are very compact, highly efficient and cost-effective, and well-suited to mass production. With the exception of a few characteristics they completely outclass their predecessors (lamps, relays, etc). The smallest, fully mounted lasers with photodiode, cooling fin and protective radiation window only takes up 50 mm<sup>3</sup>. Despite this tiny format they provide a continuous output power of 100 mW. The

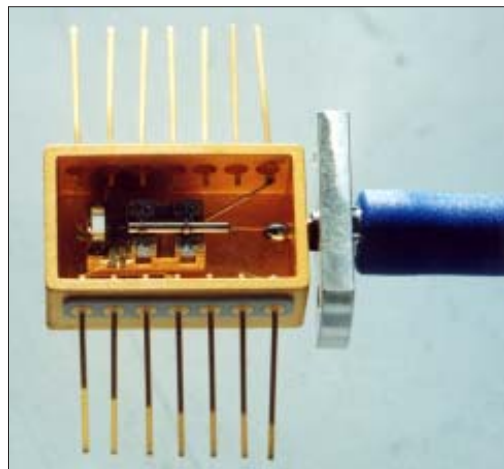

*Fig. 6-3 Interior view of a modern semiconductor laser for mounting on printed circuit boards.*

efficiency of semiconductor lasers is as high as 20 %, compared to gas lasers of the He-Ne type, which have an efficiency of no more than 2 %. Above the lasing threshold, almost 80 % of the input power is converted into light.

Semiconductor components can respond very quickly to rapid changes in the drive current. The laser beam can therefore be modulated with very high frequencies. This is not possible with gas lasers without complicated peripheral equipment.

Laser diodes have many similarities to light emitting diodes, in the same way as there are many similarities between gas lasers and luminous discharge lamps. Both laser diodes and LEDs are manufactured out of materials from groups 13 -15 of the periodic table (gallium, arsenic, indium phosphide, indium arsenide, or more complex compounds). The most important compounds are gallium arsenide and its derivatives, which lase in the wavelength range 660 - 900 nm, and indium phosphide and its derivatives which lase in the range 1300 - 1550 nm. This latter range is the optimum one for lasers to be used in fiber optic telecommunications. Visible light lies in the wavelength range 390 - 760 nm.

## Areas of application

It is not only in existing applications that the need for laser diodes has been increasing dramatically. New areas are being discovered almost daily. It is impossible to describe all the areas of application that contain or will soon contain some form of laser diode. Below is a very limited description of important and interesting areas.

### Telecommunications

The telecommunications industry has been and still is one of the most powerful driving forces behind research and development in laser diode technology. During the 1980s, telecommunications was revolutionized by the replacement of copper cable and traditional electronics with optical fiber cable and laser diodes. As discussed in previous chapters, optical fiber has characteristics which are highly suited to the transmission of wavelengths around 1310 nm and 1550 nm. This has led to the development of laser diodes and LEDs for these wavelengths, both of which correspond to a frequency of around  $2 \times 10^{14}$  Hz. A carrier with this frequency offers an enormous modulation capacity, provided that the light source can be appropriately modulated. Laser diodes are ideal for this purpose, since they react rapidly to small changes in the drive current. If single-mode fiber is used, today's telecom systems can transmit 2.4 Gbit/s; but systems for 10 Gbit/s are already being tested. 2.4 Gbit/s is equivalent to almost 32,000 simultaneous telephone conversations per fiber pair and carrying wavelength. Systems with tens of wavelengths are common today.

### Digital storage (CD players)

Even if long wavelength lasers have a wide area of application in the telecommunications industry, the market is still dominated by lasers for short wavelengths (650 - 850 nm). The most widespread use is in digital audio technology, better known as CD players. This technology is also used for digitally recorded video. The laser beam is focused into a diffraction-limited point on a rapidly rotating disc on which sound is stored as a series of long and short dashes. These have been burnt in with a high-power laser (50 mW) and are read off pressed copies by light from a low-power laser (1 mW) being reflected from the disc into a photodiode.

### The computer industry

A field of application for optical discs that is rapidly growing is as storage media in the computer industry. Despite the fact that CDs are still relatively expensive, the use of both CD-ROM and CD-R (Recordable Compact Disk) is rapidly expanding, as a single CD can contain many Gbytes (1 Gbyte = one thousand million characters). The cost for a CD-R is just about 2 USD. CD-RW (Read-Write many Compact Disk) which allows thousands of re-recordings are slightly more expensive but will on the other hand function as a large portable hard disk for the computer or as a music cassette for audio. It is obvious that much of the information that is currently stored on conventional magnetic media will be stored on optical CDs in the future, and laser diodes will transfer the information directly to computers.

### Graphics industry

It has taken only a few years for black and white or color laser printers to revolutionize the graphics industry. Before 1985, He-Ne laser diodes were used exclusively for all types of laser printer. These printers were relatively large and not at all suitable for use with personal computers. The laser diode, in combination with personal computers, has created the concept of desktop publishing, and taken only a few years to replace almost all the old technology used in office and graphics production environments.



*Fig. 6-5 Laser printers have revolutionized the graphics industry. Modern laser printers have a resolution of over 1200 dpi.*

### Manufacturing and construction industries

Laser diode based instruments are also used for measuring distance and speed, and for accurate measurement in the manufacturing and construction industries. The reading and registration of bar codes in supermarkets and the switching of railroad cars are two other common examples. Other areas of application are holo-graphy, and medical diagnostics and surgery.

## Basic theory of semiconductors

Laser diodes, LEDs and photodiodes are special applications within the field of semiconductor technology. To understand fully what occurs when a laser emits optical radiation one must have a certain knowledge of the basic atomic theories that are the foundation of semiconductor technology.

One way to describe the interaction between light and matter is to view matter as (very) tiny dipole antennas. Such a dipole can be e.g. an excited atom, a molecule, or an electron-hole pair. The electromagnetic field emitted from these dipoles can be described by Maxwells equations whether it is light or radio waves. The matter is usually described using quantum mechanics. This mixed approach is called a quasi-classical approach, since one has not yet introduced a full quantization of the electromagnetic field.

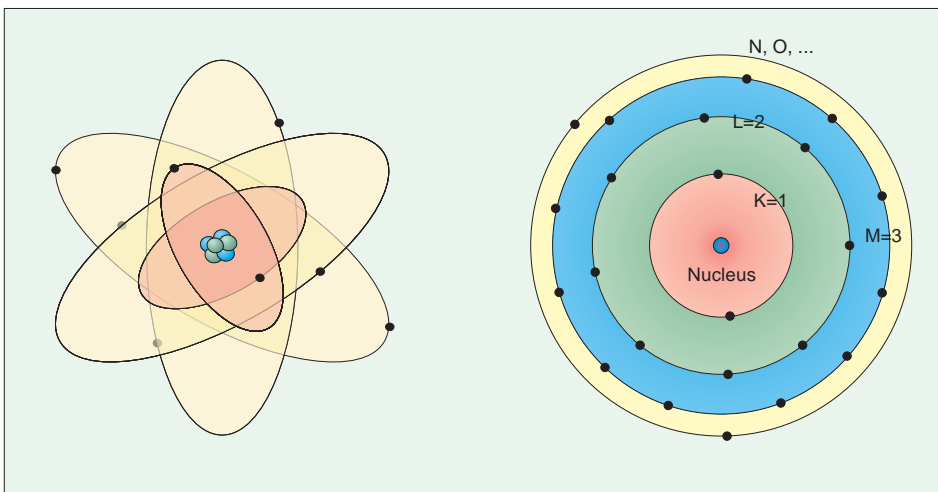

Fig. 6-6 The classical model of an atom, now almost 100 years old, with the nucleus in the middle and the electrons distributed about the nucleus in the different energy levels (shells).

The energy levels in the atom (or rather, the difference between the energy levels) determines the atom's optical spectrum or "spectral fingerprint". The most characteristic feature of this spectrum is that it is discrete and non-continuous. The spectrum of each atom shows a large number of emission and absorption lines with extremely narrow bandwidths. The hydrogen atom is in fact the only atom that is suitable for mathematical calculations without involving great complexity.

### Bohr's model of the hydrogen atom

The young Danish physicist Niels Bohr was the first theoretician to set up a model of the atom that utilized the quantum idea. Bohr's model is the basis of the more complicated and refined model that is used by researchers today, i.e., the wave mechanics model. Bohr assumed that the main part of the atom's mass was concentrated in a very small, positively charged nucleus, around which a number of electrons moved. In some epoch-making papers published in 1913, Bohr made two fundamental assumptions regarding the paths described by the electrons.



1. Among the infinite number of paths that an electron, according to classical mechanics, could describe about the nucleus, only certain paths actually occur in reality, which fulfil specific quantum conditions. Each path or quantum state is equivalent to a specific energy content of the atom, i.e., the electron-nucleus system. The state that has the lowest energy level is called the atom's ground state; all other states are called excited states.
2. The atom emits or absorbs radiation when electrons leap from one path to another; or rather, from one quantum state to another. Electrons are thus said to make quantum leaps, and it is the difference in energy between the two states that is emitted as electromagnetic radiation (light) if the initial state has higher energy than the final state. Energy is absorbed out of radiation if the initial state has lower energy than the final state. The emitted or absorbed radiation's frequency  $\nu$  is determined by the energy difference between the two states as follows:

$$E_1 - E_2 = h \cdot \nu \quad \text{Formula 6-1}$$

$E_1$  and  $E_2$  are the energies of the two states, and  $h$  is the Planck constant ( $h = 6.626 \times 10^{-34}$  J/s).

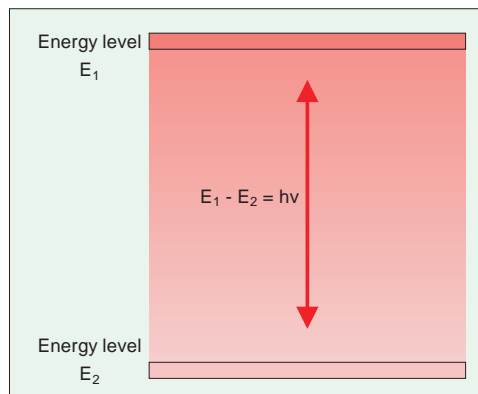

Fig. 6-7 When electrons move from one energy level to another, electromagnetic radiation may be emitted.

With this description, Bohr incorporated in his atomic model the theory - earlier brought up by both Planck and Einstein - that light occurs in the form of quanta. Due to the quantization of light, monochromatic light can be obtained if electrons are made to give off energy during quantum leaps in, for example, today's semiconductors.

### Light emitted from the hydrogen atom

As early as one hundred years before Bohr's theory of the atom, it had been established that when the light from a glowing or burning gaseous substance is divided up into colors with the help of a prism or grid, it could be seen to consist of light of different wavelengths or frequencies, i.e., spectral lines (monochromatic light lines). Each spectral line corresponds to one and the same frequency. At the end of the nineteenth century, Balmer and other physicists managed to show that the lines in the hydrogen spectrum could be ordered in series in a way that allowed the frequencies of the lines in each series to be expressed with a simple formula:

$$\nu = \frac{R}{n_2^2} - \frac{R}{n_1^2} \quad \text{Formula 6-2}$$

Here  $R$  is a constant, named after the Swedish physicist Jan Rydberg as the Rydberg constant ( $R = 1.09678 \times 10^7$  m<sup>-1</sup>).  $n_1$  and  $n_2$  are integers where  $n_2$  is constant for each series of spectral lines, and  $n_1$  - which is always greater than  $n_2$

- has a set value for each of the individual lines in the series.  $n_2 = 1$  and  $n_1 = 2, 3, 4, 5 \dots$  gives a series of lines (called the Lyman series) in the ultraviolet spectrum.  $n_2 = 2$  and  $n_1 = 2, 3, 4, 5 \dots$  gives a series of lines (called the Balmer series) in the visible spectrum. See Figure 6-8 below.

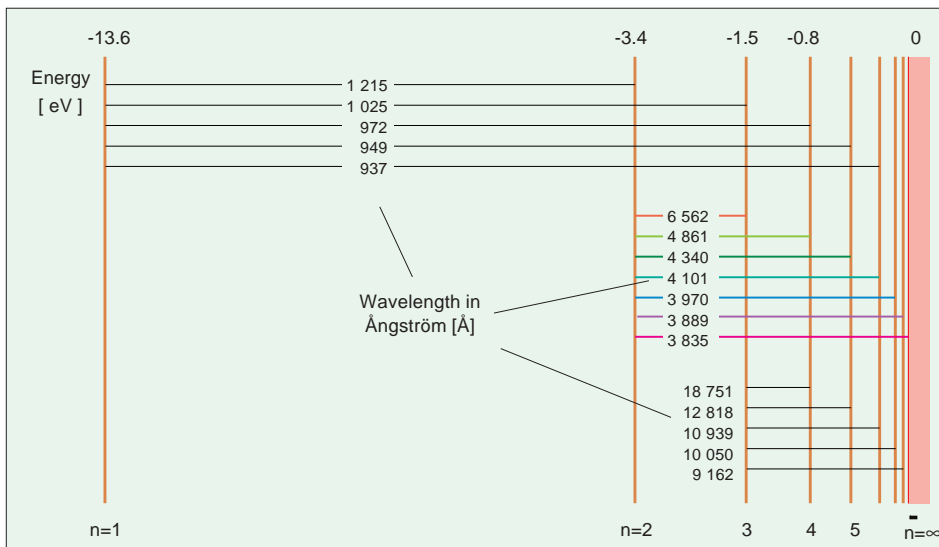

Fig.6-8 Energy levels in a hydrogen atom, electron transitions and corresponding wavelength of the emitted light when an excited electron returns to its original energy level. In total, 13.6 eV of energy is used to free an electron from the influence of the nucleus.

Bohr's model of the atom was a big step forward in explaining the characteristics of hydrogen. The experience gained from experiments on the hydrogen emission of light have since been used to explain the emission of light by other substances. The knowledge gained about the transition of electrons to lower energy levels and the emitted monochromatic light resulting from this transition has been utilized in all types of LED and laser.

## Molecular spectra

Molecular spectra are much more complex, because a molecule has a more complex electron structure, and because the atoms in a molecule also vibrate and rotate. This mobility results in emission and absorption lines in the spectrum. The atoms in a molecule could metaphorically be described as two masses held together by a spring. The atoms will vibrate at a certain frequency, and rotate at a certain speed. Both these forms of motion give rise to the emission of photons with precisely defined frequencies.

## Electrons in a solid

A crystal of a material can be regarded as a giant molecule. Both theory and simple experiments show that electrical and vibrational movements are quantized. In a crystal, a large number of energy levels with the same quantum number occur, and these cause broad energy bands in contrast to the very narrow, widely spaced energy bands that individual atoms exhibit. The number of electrons in the energy

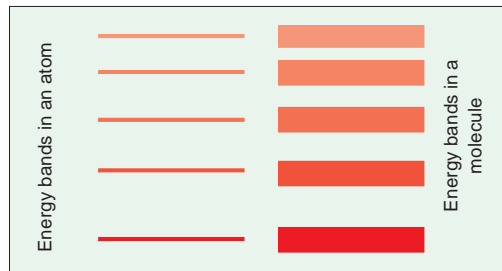

Fig. 6-9 The difference in appearance of the energy diagrams for an atom and a molecule.

levels is controlled by Boltzmann statistics. According to the Pauli exclusion principle, a maximum of two electrons can occupy the same energy state. The lower energy levels are completely filled, while the higher energy levels lack electrons.

### Valence band

The band second from the top, the valence band, is created by the outermost electrons and contains the electrons that bind the crystal together. A simple way to describe this bonding is to imagine that the electrons between two adjacent atoms form pairs, and that the atoms pass the electrons back and forth to each other. This is analogous to the description of covalent and ionic bonding of molecules. The valence band cannot then participate in the transportation of charge through the material, since it is completely full and charge therefore cannot flow. It must be pointed out, however, that this is a very simplified picture and that valence electrons are nowhere near so locally bound.

### The conduction band

The top band is called the conduction band. Electrons in the conduction band cannot be directly associated with any specific atom in the crystal. The difference in energy between the valence and conduction bands is called the band gap.

## Energy band diagram

A clear and effective way of describing the electrical properties of a conductor (usually a metal), semiconductor or insulator is to use an energy band diagram. This diagram shows the distribution of the allowed and forbidden energies for electrons in a crystal.

For an electric current to flow through a solid, electrons must flow within the substance, i.e., electrons must move from atom to atom. The following illustrations provide a schematic view of the different energy levels and their internal energy gaps for three types of solids:

- Conductors
- Insulators
- Semiconductors

The filled bands described in the Figures below are in fact the inner electron shells. Lighter atoms have one or two shells whilst heavier atoms have several (K, L, M, N...). The inner shells are not normally involved in the bonding of a crystal.

## Conductors

In a good conductor, e.g. a metal, parts of the valence band coincide with the conduction band, see Figure 6-10. The valence band, which is lower in energy than the conduction band, is completely filled with electrons. These electrons can usually not move since there are no free energy states available to them. However, since the conduction band, which is devoid of electrons, overlaps with the valence band in this case, there are lots of free states that are at the same energy as the valence electrons. These electrons can therefore easily move around in the material using the empty states in the conduction band.

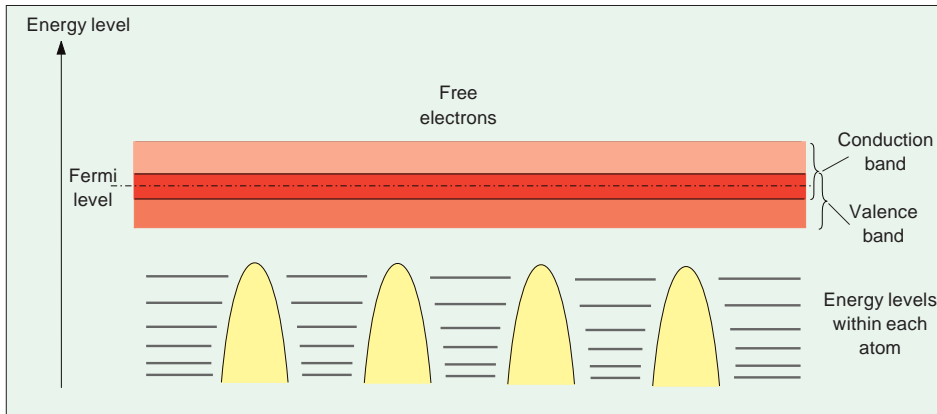

Fig. 6-10 In a conductor, the valence and conduction bands run into each other and only a small addition of energy is needed to move electrons from atom to atom.

## Insulators

In an insulator, the valence and conduction bands no longer have the same energy, they are separated by a large band gap, see Figure 6-11. In order for a current to flow, an electron must now first be excited from the valence band to the free states in the conduction band, which requires a lot of energy. In most cases, the result is very dramatic, i.e., a short circuit, which often causes substantial damage to installed components.

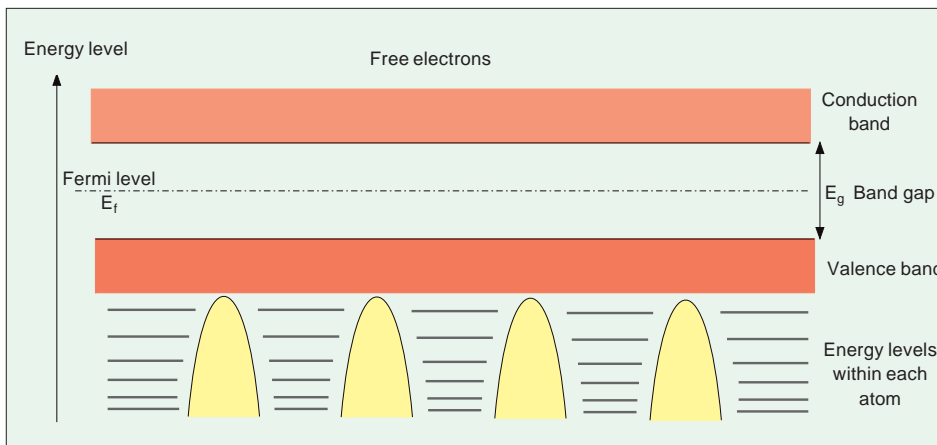

Fig. 6-11 In an insulator, there is a large gap between the valence and conduction bands. A very large amount of energy is needed to move an electron into the conduction band.

## Semiconductors

Semiconductors, which form a group between conductors and insulators, are found in Group 14 of the periodic table. The energy gap between the valence band and the conduction band is relatively small, Figure 6-12, which means that a small amount of energy is sufficient to bring about an electron current in a semiconductor.

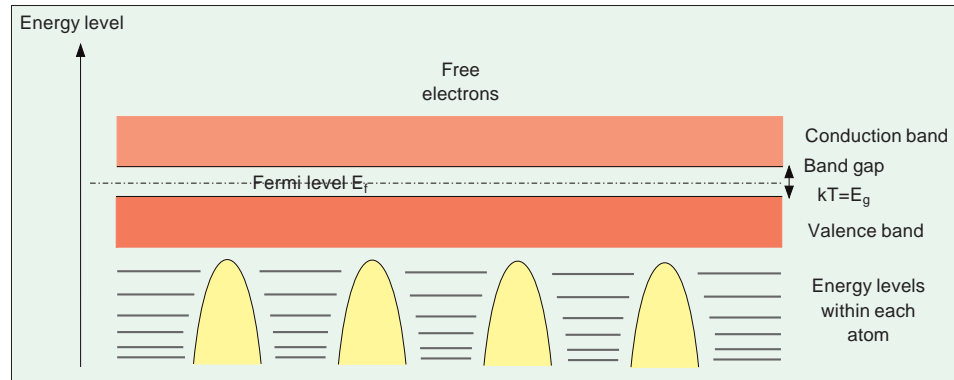

Fig. 6-12 In a semiconductor, the band gap is so narrow that the additional energy needed for an electron to move between the valence and conduction bands is temperature-dependent.

The thermal energy in the material itself at room temperature can excite an electron from the valence band to the conduction band. Therefore, the electric resistance of semiconductors lies between that of conductors (metals) and insulators, and a temperature rise results in a decrease in that resistance. Even a temperature rise of only a few degrees can increase the excitation of valence electrons into the conduction band, and thereby decrease the electrical resistance since there are many more electrons available to move under the influence of an electric field.

When we have two separate bands with moving electrons, the charges in these bands behave independently, and slightly differently because of the different energy levels and bindings in the two bands. We therefore say that the excitation of an electron creates an electron-hole pair. This electron in the conduction band, and the “hole” left by the electron in the valence band can both carry current independently of each other (charges can now move in both bands).

Note that the two currents generated by the moving hole and electron, both flow in the same direction because the hole appears to move in the opposite direction as the electron, and it also has an opposite charge. It is also important to note that the hole and the electron act as independent charged particles, and we therefore often talk about charge carriers, since we do not always need to keep track of whether the current is a hole current, an electron current, or a mixture of both. The simplest and most symmetrical semiconducting element is silicon (Si). Germanium (Ge) is also a semiconductor and was used a great deal in the first transistors and diodes, but is being increasingly replaced by silicon. Silicon is currently the material used in 99 % of all semiconductor manufacture.

## The structure of the silicon atom

In the silicon atom electron configuration, four electrons are placed in the outermost electron shell. These four are part of the valence band, but can - by the addition of a small amount of energy - be moved to the conduction band. Figure 6-13 gives a simplified, two-dimensional picture of a number of silicon atoms in a silicon crystal. Around each atom there are four electrons (shown as small circles with minus signs inside them) that are localized to the valence band.

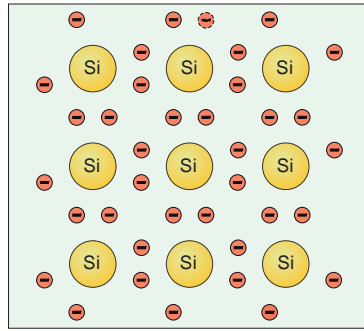

Fig. 6-13 The structure of a silicon crystal, where the outermost electrons of each atom are “shared” so that a full outer shell is formed.

From a superficial point of view, it would seem that the band structure of all semiconductors is more or less the same, but there are large differences in the size of the band gap and in the influence of temperature on the

distribution of the electrons in the bands.

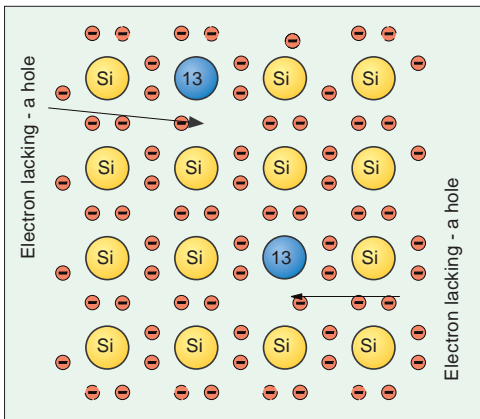

Fig. 6-14 Electron holes are formed if the silicon is doped with a substance from Group 13 of the periodic table, e.g., aluminium, gallium or indium.

By adding a very small amount of a substance from Group 13 or Group 15 of the periodic table, the electron structure can be altered. This introduces new energy levels, inside the band gap, that has a very strong influence on the electrical behavior of the material. The addition of foreign substances is called doping and the knowledge gained about the changes induced by doping have formed the foundation of modern semiconductor technology.

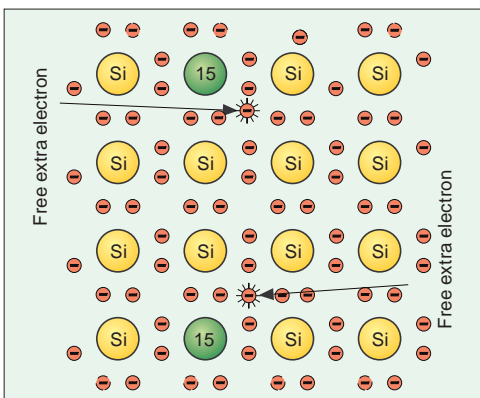

Fig. 6-15 If silicon is doped with substances from Group 15 in the periodic table, e.g., phosphorus or arsenic, there will be an extra, “free” electron in the doped silicon’s crystal lattice.

The addition of a substance from Group 13 to silicon results in a shortage of valence electrons. An excess of holes is created, and the resulting semiconductor is said to be p-doped (see Figure 6-14). In general, the expression “p-material” is used for a p-doped semiconductor. In combination with other types of doped semiconductor, the expression p-layer is used.

When instead a substance from Group 15 is added to silicon, the result is an excess of electrons. This is called an n-doped semiconductor.

If different layers of *n*-doped and *p*-doped semiconductors are combined, junctions are obtained that can be utilized in a variety of ways. The remainder of this, and the next, chapter will deal with three specific applications of this knowledge: *laser diodes*, *light emitting diodes* and *photodiodes*.

### Fermi level

The electrical properties of a semiconductor are temperature-dependent because the number of electrons that become excited and cross the band gap increases rapidly as the temperature increases. A clearly defined border between the occupied and unoccupied energy levels in the bands exist only at absolute zero temperature (0 °K). At higher temperatures, this border is rather indistinct, and the Fermi level is thus the energy at which the probability that an allowed energy level is occupied by a charge carrier is 0.5. In undoped material, the Fermi level is around the middle of the band gap. When the material is doped, the Fermi level ( $E_F$ ) is shifted up or down in the energy level diagram. In *p*-doped material, the Fermi level does not reach up to the edge of the valence band, and charge is transported through the material via a hole current in the valence band. In an *n*-doped material, the states right up into the conduction band are occupied by electrons, which results in an electron current through this band. In the following pages, band diagrams will be used to describe the distribution of charge carriers around the *p-n* junction.

## How a laser functions

Earlier in this chapter, we looked at how electrons that return to their original energy states emit excess energy as light (sometimes visible light). In all substances, electrons can be made to move from a lower to a higher energy level by the addition of energy to the atom. To excite the electrons, energy can be transferred in the form of radiation, heat or electric fields. Excitation, or pumping, through the use of electric fields is the technique that is of most interest in fiber optic applications.

The function of a laser is based on achieving - within a narrow space - an environment that makes stimulated emission possible. Stimulated emission means that an optical radiation field co-operates with an amplifying medium so that additional radiation of the right phase and frequency is added to the existing field. It is therefore necessary to use a material in which such processes have a high probability of occurring and will not be counteracted by losses. Energy must be added in some form. For the efficiency to be as high as possible, the energy must be concentrated within a well-defined volume where the optical field is to be localized. In other words, the following are needed:

- a suitable material
- a pumping mechanism
- confinement of the pump energy
- confinement of the emitted radiation

Under these conditions, we can achieve amplification of the optical field that is greater than the unavoidable losses: in other words, we have built a LASER (Light

Amplification through Stimulated Emission of Radiation). In a laser diode, the material is GaAs or GaAsP, for example; the pumping mechanism is a forward-biased voltage applied to the  $p$ - $n$  junction; the electric and optic confinement is obtained by using different combinations of materials in the various semiconductor layers and by cleaving the crystal to obtain an optical cavity.

## Absorption

If a photon of frequency  $\nu$  is allowed to penetrate the electron cloud around an atom, molecule or crystal - provided that the energy of the photon is equal to or higher than the difference between two energy levels in the material - then the photon can cause the transition of an electron from one energy level to another, higher, energy level. In semiconductors, a radiation quantum is absorbed which excites an electron from the valence band into the conduction band, an electron-hole pair (e-h pair) is created.

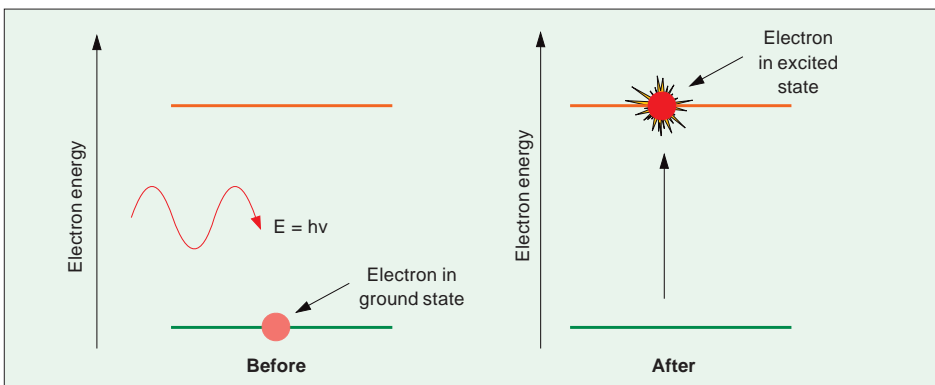

Fig. 6-16 An electron is absorbed and an e-h pair is formed.

## Spontaneous emission

In Figure 6-17, the most common type of light emission is shown, an excited electron in the conduction band comes sufficiently close to a hole in the valence band and recombines, at which point the energy difference is emitted in the form of a light quantum (photon). This process is also generally known as fluorescence. The photon that is emitted has a frequency corresponding to the difference between the two levels, which are reasonably well defined. Other properties of the emitted radiation, such as phase, polarization and direction, are random. This discerns the *spontaneously* emitted radiation from the *stimulated* emission.

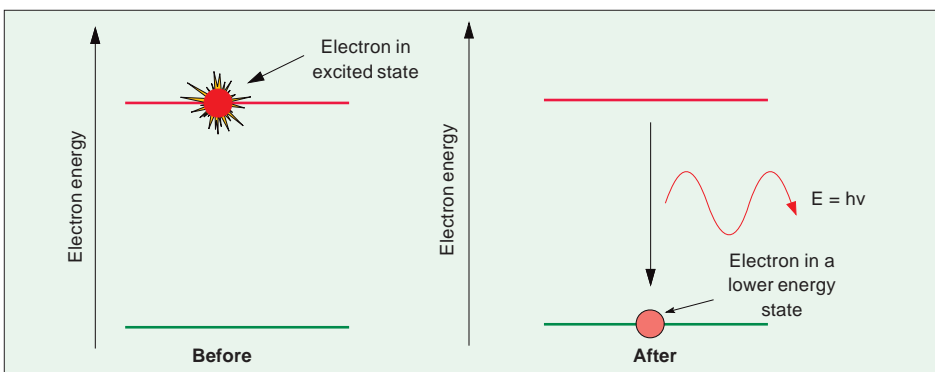

Fig. 6-17 Spontaneous emission.



## Stimulated emission

Figure 6-18 shows how an incoming photon interacts with an e-h pair so that it recombines. The emitted quantum of light is an exact copy of the stimulating photon (which is preserved). The process, known as stimulated emission, means that recombination occurs through interaction with an electromagnetic field. In simple terms, we can say that there is a very strong connection between an e-h pair with a certain energy difference and an electromagnetic field with a frequency

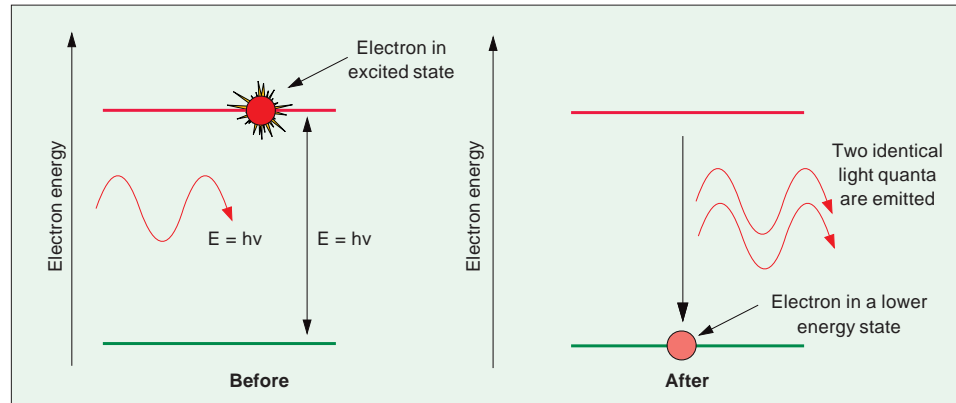

Fig. 6-18 The incident photon stimulates an electron transition that emits a photon with characteristics identical to those of the incident photon.

that exactly corresponds to this energy difference. The photon can thus stimulate an e-h pair to recombine without itself being destroyed. The new photon that forms during recombination is identical to the incident photon (in terms of energy, phase, polarization and direction of radiation). The stimulated radiation thus falls within a very narrow energy band, i.e., the radiation is coherent. It should be pointed out, that this stimulated emission is the inverse of the previously described absorption, and that the quantum mechanical probabilities of these two processes are equal. Which of the two processes that dominate over the other therefore depends on the number of e-h pairs at each energy level.

## The design of a laser diode

### p-n junction

Since the relative amounts of spontaneous and stimulated radiation depends on the number of available holes and electrons on each energy level, we must introduce some means of influencing these populations. At thermal equilibrium, there are many more electrons at lower than at higher energy levels. An incoming photon is then very likely to be absorbed. Only if an electron had, by chance, been excited thermally in the right place and at the right time could stimulated emission occur. The creation of more excited e-h pairs than electrons that can still be excited requires a process called population inversion, which can be achieved through the injection of an electron beam, or through optical excitation. One of the major advantages of semiconductors is the possibility of inducing electroluminescence, i.e., the excitation of e-h pairs by injecting minority carriers into a p-n junction. This is a simple and very efficient method of excitation.

The distribution of electrons and holes in p- and n-layers are evenly distributed if no voltage is applied (see Figure 6-19). The figure also shows the distribution of electrons and holes if a forward biased voltage is applied.

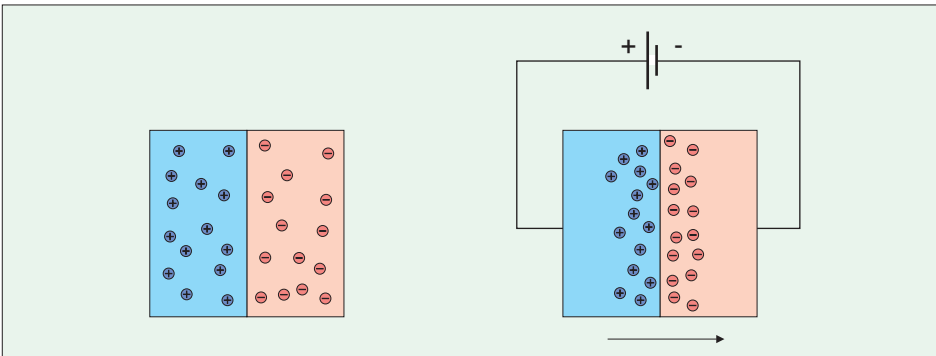

Fig. 6-19 With a forward-biased voltage, an accumulation of electrons and holes is obtained at the junction between the p- and n-layers.

The band diagram for a normal p-n junction without forward-biased voltage is shown in Figure 6-20 without a forward-biasing voltage the fermi level,  $E_f$ , is the same throughout the material as a consequence of the semiconductor being in a state of equilibrium.

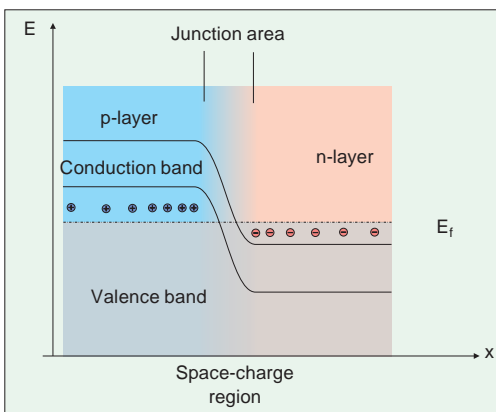

Fig. 6-20 The energy band diagram for a p-n junction with heavily doped p-layer and n-layer.

To compensate for the imbalance between the excess of electrons in the n-material, and the excess of holes in the p-material, a space-charge region is formed around the p-n junction. This space charge is created by the ionized donors and acceptors in the crystal when “their” electrons and holes recombine at the interface. The space-charge builds up to precisely the voltage required to prevent a current flowing from the p to the n-side.

Since the external voltage over the device is zero, no current should, of course, flow through it in this situation.

If now an external voltage is applied across the diode, it can either add to the existing internal voltage over the p-n junction created by the space-charge (reverse bias), or the external voltage can subtract from the internal voltage (forward bias), as shown in Figure 6-21.

If the voltage gives a forward bias, the internal barrier caused by the space charge is decreased and a current can start to flow over the barrier. This region

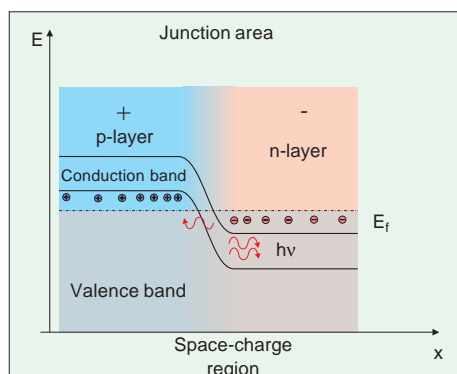

Fig. 6-21 A forward biased p-n junction. The current flowing through the device causes a large number of electrons to recombine with the holes in the junction area, and loose their excess energy as light quanta, photons.

was previously devoid of free charge carriers. Electrons from the n-material and holes from the p-material now meet in large numbers in the space charge region around the p-n junction where they quickly recombine.

The recombination generates spontaneous emission from the junction area (if the materials are chosen properly). If the doping of the n- and p-layers is strong, and the current large enough, we can also achieve population inversion, that is, there are more unrecombined e-h pairs than there are recombined pairs (we feed in new electrons at least as fast as they recombine with the holes). Under these conditions we can also obtain stimulated emission and optical gain. By finally placing this junction inside an optical cavity that provides feedback of the generated radiation, we have an oscillator, a laser.

## Laser structures

### A simple laser

To optimize the performance of the laser diode for as many applications as possible, a variety of different laser designs have evolved. The simplest laser diodes are called “broadstripe Fabry-Perot” lasers, see Figure 6-22. Broadstripe comes from the current contact being simply a rather wide ( $> 10 \mu\text{m}$ ) metal stripe along

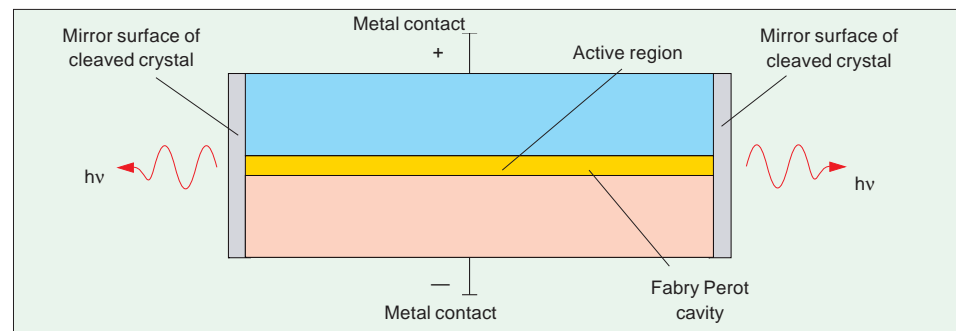

Fig. 6-22 A laser of the simplest design. This type of laser - generally known as Fabry Perot laser - has only one p-n junction. For this reason it is called a homojunction laser.

the laser. Fabry-Perot is the name of the optical cavity i.e. the mirror arrangement that gives the feedback in the laser oscillator. The mirrors are obtained by cleaving the crystal planes at both ends of the laser chip. The difference in refractive index between the air and the semiconductor causes a partial reflection that allows some of the radiation to get out of the laser, and some to be reflected to give feedback. These simple lasers often give non-linear output power characteristics, due to poorly controlled modes in the cavity, and they also oscillate at many wavelengths simultaneously.

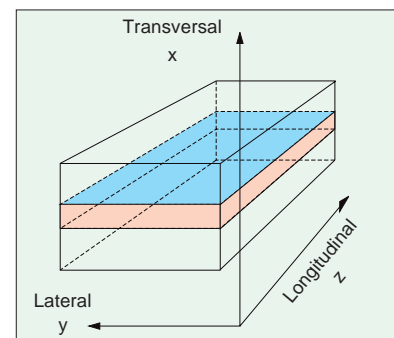

Fig. 6-23 Definition of lateral, longitudinal and transversal directions in a laser structure.

## The heterostructure laser

To get a better spatial mode stability, the “buried heterostructure laser” (BH-laser) was developed. Heterostructure means that the p-n junction is made up of several layers with different bandgaps. The change in bandgaps influence both the refractive index and the motion of the carriers. By designing the p-n junction so that it consist of a thin ( $< 0,5 \mu\text{m}$ ) layer with low bandgap surrounded by layers with higher bandgaps, the carriers and the optical radiation are better confined to the transversal direction. This gives both a lower threshold current and better mode stability.

To get the same advantages also in the lateral direction one must grow the laser material in several steps with patterning and etching in between, just as for ordinary semiconductor devices. The most common method is to first grow a heterostructure such as described above. Thereafter one etches away all material except a narrow ( $1-2 \mu\text{m}$ ) ridge that will become the laser cavity. Then new material with a different composition is regrown on the sides of the ridge. This material is chosen to have a larger bandgap than the active layer in the p-n junction. One now has a laser with an active layer surrounded by higher bandgap material in both the lateral and transversal directions. This gives a very good control over both carriers and the generated optical radiation.

Figure 6-24 shows the cross sections of three types of modern laser structures. First (top left) is the ordinary BH-structure described above. At the top right is a “v-groove” laser, which obtains a similar guiding in two dimensions with a planar structure. The third laser is a “ridge-laser” which gets its lateral guiding from the air-semiconductor interface located close to the active layer.

These designs concern the *spatial* carrier and mode control. If one wants to improve the *spectral* properties of the laser one designs different feedback characteristics of the optical cavity. All the above laser designs can be used with the

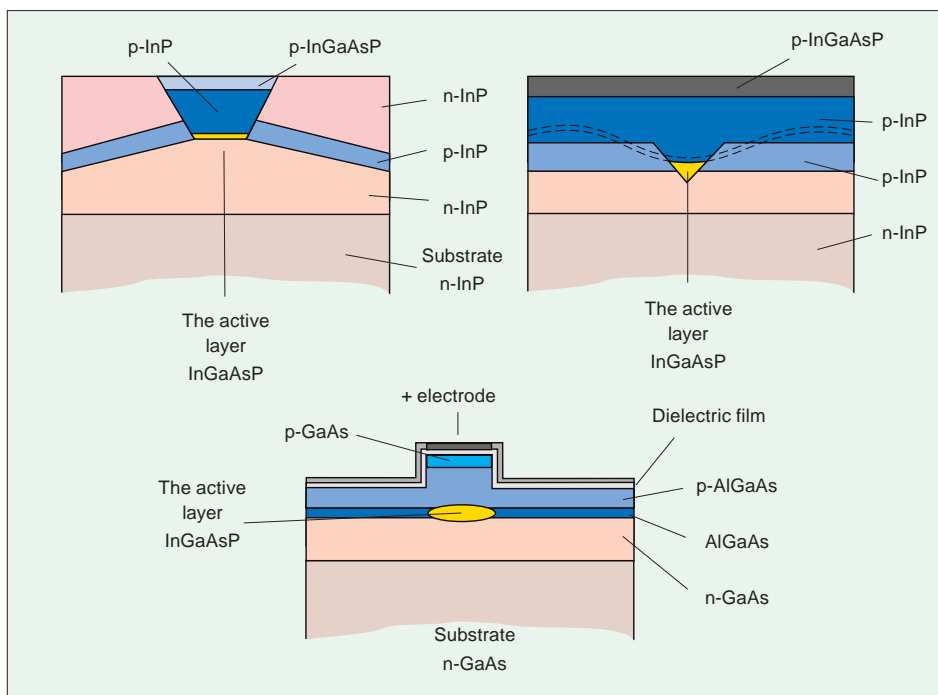

Fig. 6-24 Heterojunction laser diodes. Top left and right: two different types of BH laser diode - one planar and the other non-planar. Bottom: a ridge laser diode.

simple Fabry-Perot cavity which produces a multimode spectral behaviour, i.e. the laser oscillates on many frequencies at the same time. If one wants a single-mode spectrum, which is necessary in most advanced applications, one can design the optical cavity as a grating, a so called “distributed feedback laser” (DFB-laser).

A laser designed for communication purposes has a lasing threshold of, typically, 10-15 mA, and an output power of 10 mW. The lasers can usually be modulated at data rates over 1 Gb/s, some even higher, and are therefore highly suitable for long-distance, high-speed transmission systems.

## Coupling of the laser diode to the fiber

### Fiber as a lens

The size of the light emitting area (typically  $0.2 \times 1 \mu\text{m}$ ) of the laser diode is similar or even smaller than the wavelength of the emitted light. The output beam is not parallel, but a cone diverging with an angle of 30-50 degrees, this effect is called diffraction. This makes it necessary to focus the light in some way if one wants to get it into a fiber without too much loss. If no special precautions are taken, so that the flat fiber end is just positioned as close to the laser as possible (a few  $\mu\text{m}$ ), a coupling efficiency of about 10% can be achieved. For this reason, a lens or lens system is mounted between the laser and fiber end to collect the light within the fiber’s numerical aperture (NA), in order to obtain the best possible coupling of light into the fiber (shown in Figure 6-25). A fiber lens lies in a V-shaped groove directly in front of the laser diode. The V-shaped groove forms a  $90^\circ$  angle with the laser beam and the fiber pigtail that the light is to be coupled into. The efficiency of this type of setup is around 30 %.

All components are hermetically sealed in a little package of plastic or metal for increased stability. Inside the package, there is normally a photodiode as a monitor to provide some feedback, and control and drive circuits. The optical radiation is carried in the fiber that passes out of the seal. Normally, less than one meter of fiber protrudes from the package.

A detector diode - most easily mounted behind the laser diode - monitors the radiation that passes through the rear “mirror” in the laser diode. Alternatively, a

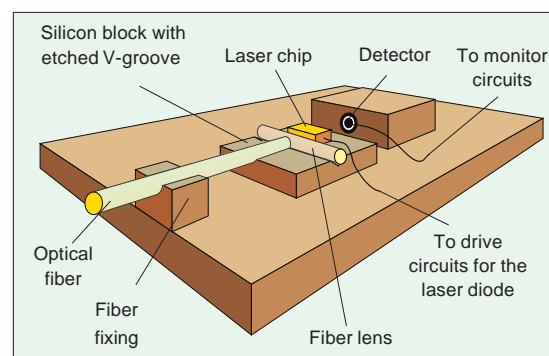

beam splitter is used: a certain amount of the light to be used in the system is tapped off and fed back to monitor the laser diode. The laser diode, the total size of which is no greater than an ordinary integrated circuit, often has an affixed cooling body.

Fig. 6-25 Integrated laser chip with fixed fiber, lens system and monitoring detector.

## Microlenses

The fiber-like lens of the original laser diodes has been superseded by a microlens as shown in Figure 6-26. With this type of lens coupling efficiencies of more than 50% can be achieved.

The diameter of a microlens is only 8–15  $\mu\text{m}$ .

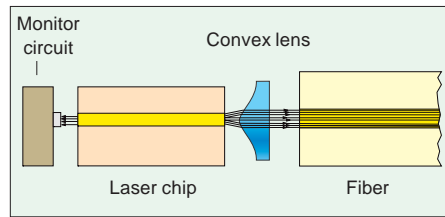

Fig. 6-26 With the help of a microscopically small lens, the light is converged from the laser diode into the fiber.

## Tapering

A third method, called tapering, has been developed in recent times. The fiber is heated and drawn so that a tapered fiber droplet forming on the fiber end will serve as a lens. To manufacture a fiber with a tapered end, programmable fiber splicing equipment is used, e.g., The FSU 975 from Ericsson. Figure 6-27 gives a schematic view of how the fiber is coupled to a laser diode and how the light is refracted in the droplet-end of the fiber.

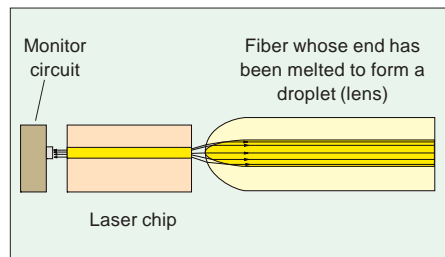

Fig. 6-27 Schematic diagram showing a tapered fiber end.

## Cooling and protection of the laser diode

For laser diodes intended for use in advanced systems, an active cooling device is generally built in the form of a heat pump (a Peltier element) together with an optical isolator. The optical isolator, which functions as a diode and only lets through light emitted from the laser diode, prevents the backscattering of the light into the laser diode. Such reflected light may otherwise interfere strongly with the functioning of advanced optical systems.

## Light emitting diodes

The other very important component for fiber optic communication is the light emitting diode (LED). The LED differs from the laser diode primarily in that, in an LED, there is no stimulated emission of light. The LED functions according to the principle of spontaneous emission, which was described above in the section on laser diodes. Currently, the LED has a few disadvantages compared to the laser diode.

- lower power coupled into the fiber
- relatively narrow modulatable bandwidth, normally  $< 50$  MHz (although some LEDs can produce up to 150 MHz)
- broader optical spectral width.

These disadvantages might make the LED appear to be a much less attractive option than the laser diode. However, the LED has many advantages over the laser diode and, in many situations, can predominate in the choice of components for fiber optic communication. Its advantages are:

- Simpler manufacture. No reflecting end surfaces. No stripe geometry required in the manufacture.
- Cheaper. The simple design of both the LED and drive circuits means a total reduction in costs - which is always a major consideration.
- Dependability. An LED does not age as fast as a laser diode.
- Less temperature-sensitive. The light intensity in relation to the drive current is less affected by temperature variations than the light intensity of a laser diode.
- Linearity. An LED can be made linear quite easily over a relatively large range of drive currents, which makes LEDs more suitable for analog modulation than a laser.

These advantages and disadvantages have meant that the laser diode has been used mainly in systems for long distance communication, whereas LEDs have been used primarily in local area networks (LAN), computer applications and TV monitoring systems. Fiber Distributed Data Interface (FDDI) is a regulatory system that was developed solely for fiber optic communication: In this system for data traffic the optical transmitter is an LED.

LEDs are manufactured from the same combinations of materials as those used for laser diodes. An LED made of GaAs/AlGaAs is suitable for shorter wavelengths up to 870 nm. For wavelengths (1310 nm and 1550 nm) more suited to utilize the good properties of optical fibers, a combination of e.g. InGaAs and InP is used.

### The dual heterojunction LED

The functioning of a dual heterojunction (DH) LED is described here as an example of how an LED functions. The structure of the LED is shown in Figure 108. The LED consists of a p-layer of GaAs between a p-layer of AlGaAs and an n-layer of AlGaAs. When a supply voltage is applied, the electrons migrate from the n-layer into the p-layer of GaAs where they become minority carriers. These

minority carriers diffuse in from the interface and recombine with majority carriers (holes). During recombination, energy in the form of photons is emitted. The energy (frequency specific) of these photons corresponds to the energy gap in the GaAs p-layer. The electrons are prevented from diffusing into the AlGaAs p-layer by a potential barrier between the two p-layers. Because electroluminescence only appears in the thin GaAs layer, good internal quantum efficiency and high beam density are obtained. The light is emitted without being reabsorbed in the AlGaAs layer, because the band gap in this layer is much greater than the energy of the emitted light and the band gap in the GaAs. LEDs with a DH structure are common when high efficiency rather than coherent light is required. The disadvantage is that the portion of the light coupled into the fiber is relatively small.

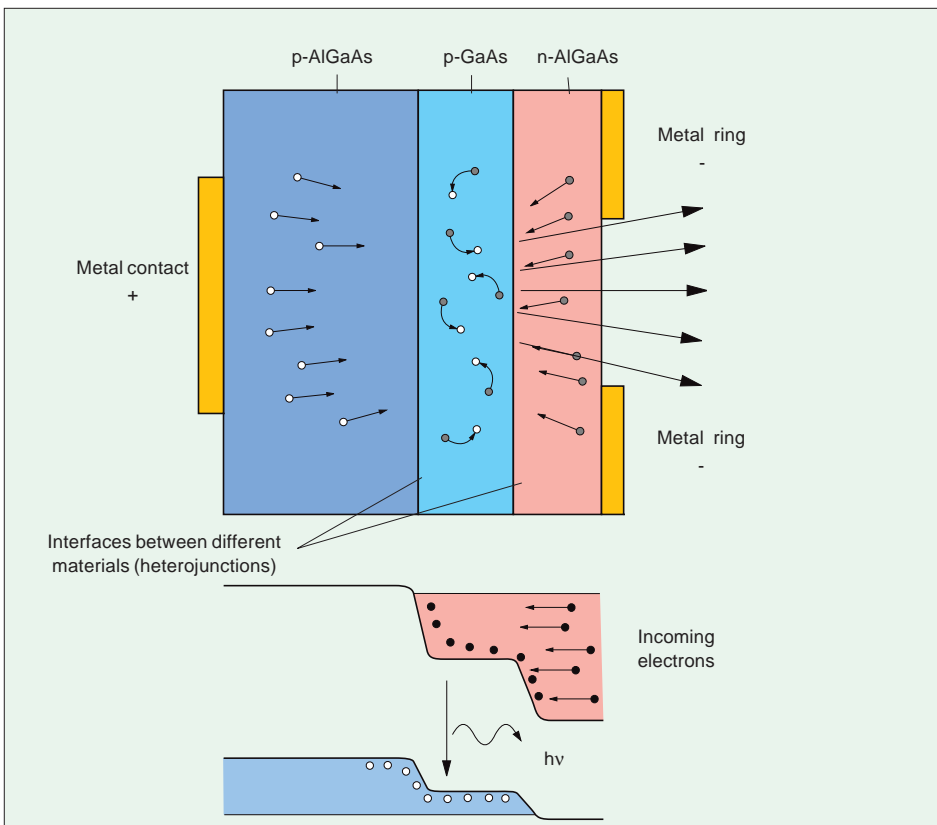

Fig. 6-28 Dual heterojunction (DH) LED. The upper illustration shows the different layers; the lower shows the energy band diagram for the LED.

### Different types of LED

There are four main types of LED, of which the first two listed below are used for fiber optic communication and the other two for alarm installations, remote-control of TV and video equipment, counting devices for industry, etc.

- Burrus type surface emitting LED
- Edge emitting LED
- Planar LED
- Dome LED.



### Surface emitting Burrus LED

Figure 6-29 shows a Burrus LED with connected fiber. The etched groove in the n-layer of GaAs can be clearly seen. By etching away almost the entire n-layer over a small surface area (the groove), the absorption of light is reduced in this layer, while the remainder of the n-layer allows a relatively strong current to flow through the diode. The LED in the Figure below has been made for the wavelength range 800 - 900 nm. Internal absorption is minimized thanks to the large band gap in the layers adjacent to the active zone. A rear reflecting layer of  $\text{SiO}_2$  gives strong forward radiation. The width of the groove corresponds to the fiber diameter to obtain the best possible coupling of light into the fiber. Optimal coupling is obtained when the radiating surface corresponds to the light-guiding surface of the fiber core.

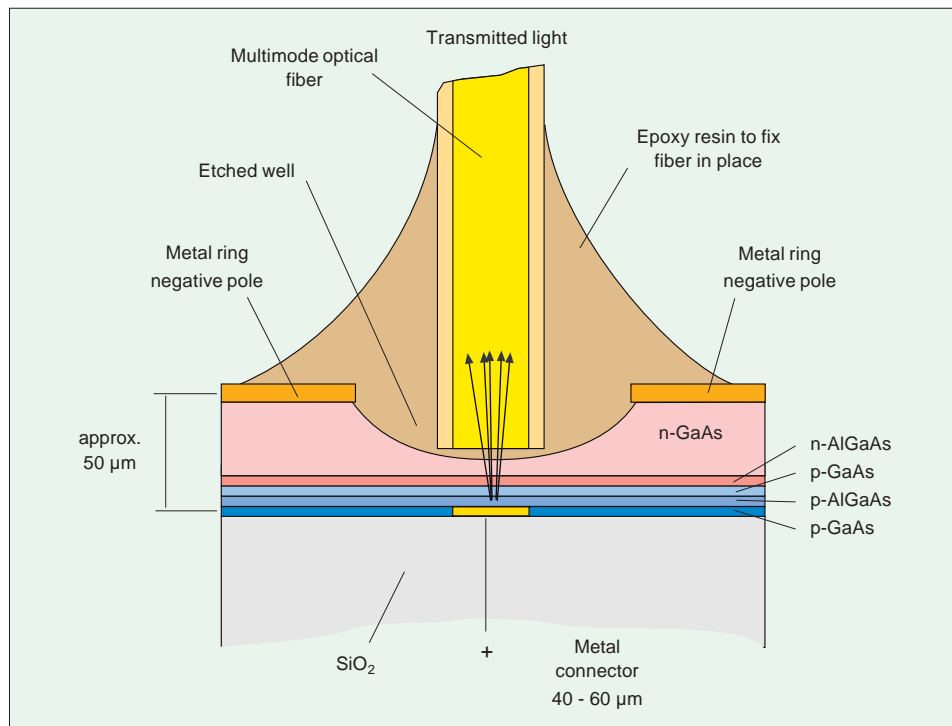

Fig. 6-29 Burrus type LED with an etched groove to minimize absorption in the n-layer of GaAs.

### Edge emitting LED

Edge emitting LEDs are constructed in a similar manner to conventional stripe lasers. In these LEDs, the technique of using transparent light-guiding layers combined with a very thin active layer (50 - 100  $\mu\text{m}$ ) is used. The light generated in this latter layer is dispersed directly into the transparent layer and, hence, reduces self-absorption. The transparent layer functions as a waveguide, so that a light cone with an angle of  $30^\circ$  to the vertical plane and around

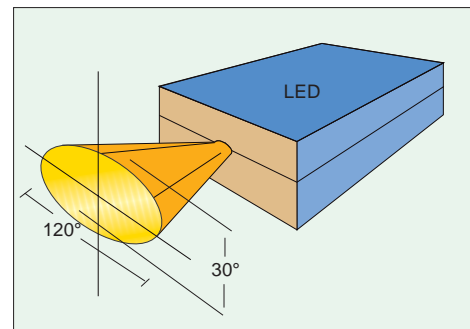

Fig. 6-30 The radiation lobe is an ellipse with an opening of around  $115 - 125^\circ$  in horizontal direction and  $25 - 35^\circ$  in vertical direction.

120° to the horizontal plane is obtained (see Figure 6-30). One end surface is coated with a reflecting layer, which means that almost all of the radiation is guided in one direction. Through the use of transparent wave-guides, from 4 - 7 times more light can be coupled into an optical fiber with a small numerical aperture, than if a surface emitting LED is used.

## The efficiency of the LED

The lack of optical amplification through stimulated emission means that the efficiency of an LED is wholly dependent on how many photons are generated by excited electrons. Taking into consideration non-radiating junctions in defects and impurities in the crystalline structure, a quantum efficiency of around 50 % can be expected for homojunction LEDs. If a heterojunction LED is used, the expected efficiency is 60 - 80 %.

## Characteristics of lasers and LEDs

### Output power

The greatest difference between a laser diode and an LED, see Figure 6-31, can be seen by studying the I-P diagram for both components. The laser diode follows the same type of curve as the LED up to a point (the threshold) when the current  $I$  causes the laser diode to begin to lase. After this point (stimulated emission), the laser diode's output power rises sharply and almost linearly. The LED, on the other hand, which is based on spontaneous emission, has no threshold point but continues to increase proportionally its power output in relation to the drive current. This goes on until the output power reaches a point where it begins to diminish, i.e., when the semiconductor becomes hot ( $> 70^{\circ}\text{C}$ ).

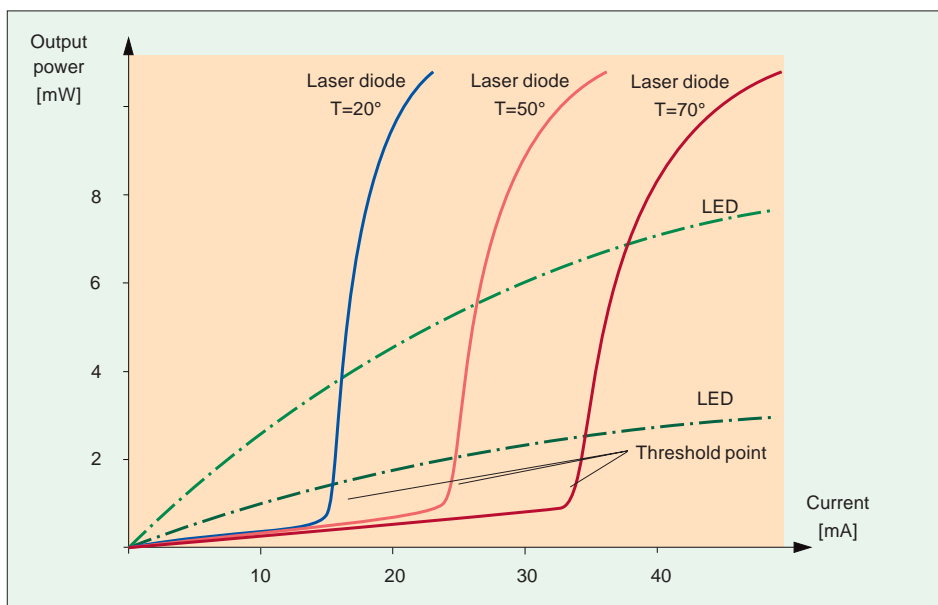

Fig. 6-31 The diagram above shows the relationship between drive current and output power. The laser diode functions like an ordinary LED up to the threshold point.

## Radiation lobe

The radiation lobes for LDs and LEDs, Figure 6-32 are also widely different. The LD's radiation has a more forward directional lobe while the LED's radiation lobe is almost circular.

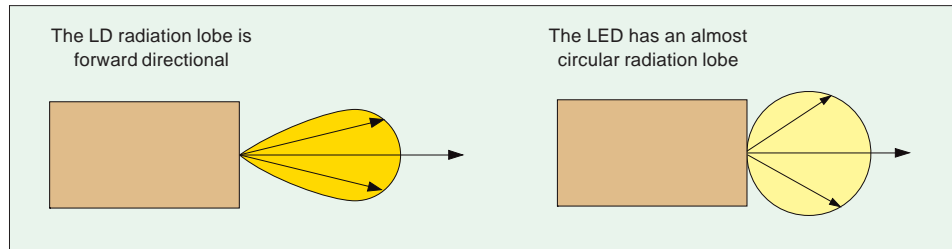

Fig. 6-32 The differences in radiation profile between a LD and an LED.

## Spectral width of LDs and LEDs

The spectral width of a LD or LED is the width of the optical spectrum. The bandwidth is the electrical modulation bandwidth. There is often some confusion about these terms. The optical spectrum consist of, firstly, the carrier, which in this case has a frequency of about  $10^{14}$  Hz. Secondly, if the LD or LED is modulated, sidebands will appear on both sides of the carrier, just as for any transmitter. These sidebands correspond to the electrical modulation bandwidth.

The frequency purity of the signal from a LD or LED is not as good as for other lasers. Therefore, the sidebands are often hidden in a broad and often rather complicated optical spectrum where it is impossible to discern the different signal components as well as in (e.g.) a radio transmitter spectrum.

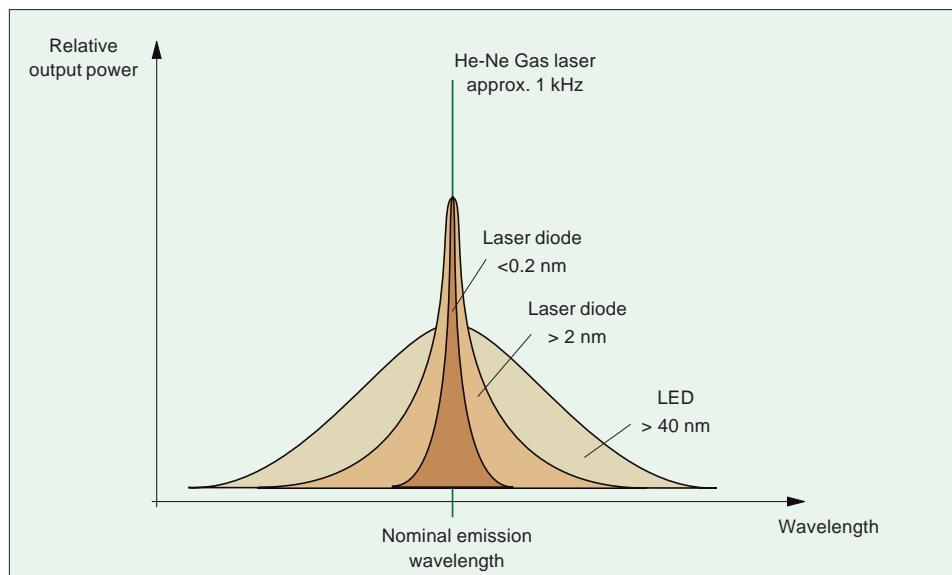

Fig 6-33. Optical spectra of a gas laser with an extremely narrow spectral width, a (multimode) LD with a spectral width of 0.2-5 nm, and an LED with a typical spectral width of more than 40 nm.

By taking the derivative of the relation between frequency and wavelength;  $f=c/\lambda$ , we obtain the relation between the width of an optical spectrum, measured in frequency or wavelength as:

$$\Delta f = \frac{c}{\lambda^2} \cdot \Delta \lambda \quad \text{Formula 6-3}$$

#### Calculation example

One LD has a spectral width of 0.2 nm another LD has a spectral width with 2 nm and finally a LED with a spectral width of 50 nm. What are the equivalents of these values in GHz at 1550 nm?

$$\Delta f = \frac{3 \cdot 10^8}{(1550 \text{ nm})^2} \cdot 0.2 \text{ nm} = \frac{3 \cdot 10^8 \cdot 2 \cdot 10^{-8}}{1.55 \cdot 10^{-6} \cdot 1.55 \cdot 10^{-6}} \approx 25 \text{ GHz} \quad \text{for an LD with 0.2 nm spectral bandwidth}$$

$$\Delta f = \frac{3 \cdot 10^8}{(1550 \text{ nm})^2} \cdot 2 \text{ nm} = \frac{3 \cdot 10^8 \cdot 2 \cdot 10^{-8}}{1.55 \cdot 10^{-6} \cdot 1.55 \cdot 10^{-6}} \approx 250 \text{ GHz} \quad \text{for an LD with 2 nm spectral bandwidth}$$

$$\Delta f = \frac{3 \cdot 10^8}{(1550 \text{ nm})^2} \cdot 50 \text{ nm} = \frac{3 \cdot 10^8 \cdot 2 \cdot 10^{-8}}{1.55 \cdot 10^{-6} \cdot 1.55 \cdot 10^{-6}} \approx 6250 \text{ GHz} \quad \text{for an LED with 50 nm spectral bandwidth}$$

We see that the width of a laser spectrum is much wider than the electrical modulation bandwidth of a few GHz. This explains why the sidebands are not directly visible in the optical spectrum. Only for special lasers and modulation formats can one start to see the individual sidebands in the optical spectrum.

## Modulation

Just as with a radio transmitter, many different modulation formats can be used to transfer information via an optical carrier. The simplest, and today most common, is to just switch the light on and off corresponding to the ones and zeroes of a modulating digital bit pattern. This is called (pulse) intensity modulation (IM). This is not unlike the morse-code invented for telegraphy in the 19th century!

In principle, however, one can use all the techniques invented for radio even in the optical domain, both for analog and digital signals. Such techniques are e.g; amplitude modulation, frequency modulation, and phase modulation, see Figure 6-34. One can also use coherent techniques that are the optical equivalent of the common superheterodyne receiver, where two light beams are mixed on a photodiode, and produce an intermediate frequency corresponding to the difference in optical frequency between the two lightbeams.

The most common types of modulation used today are:

- intensity modulation (IM)
- amplitude modulation (AM)
- frequency modulation (FM)
- phase modulation (PM)

For optical fiber, intensity modulation is the most frequently used method of transferring information between two points.

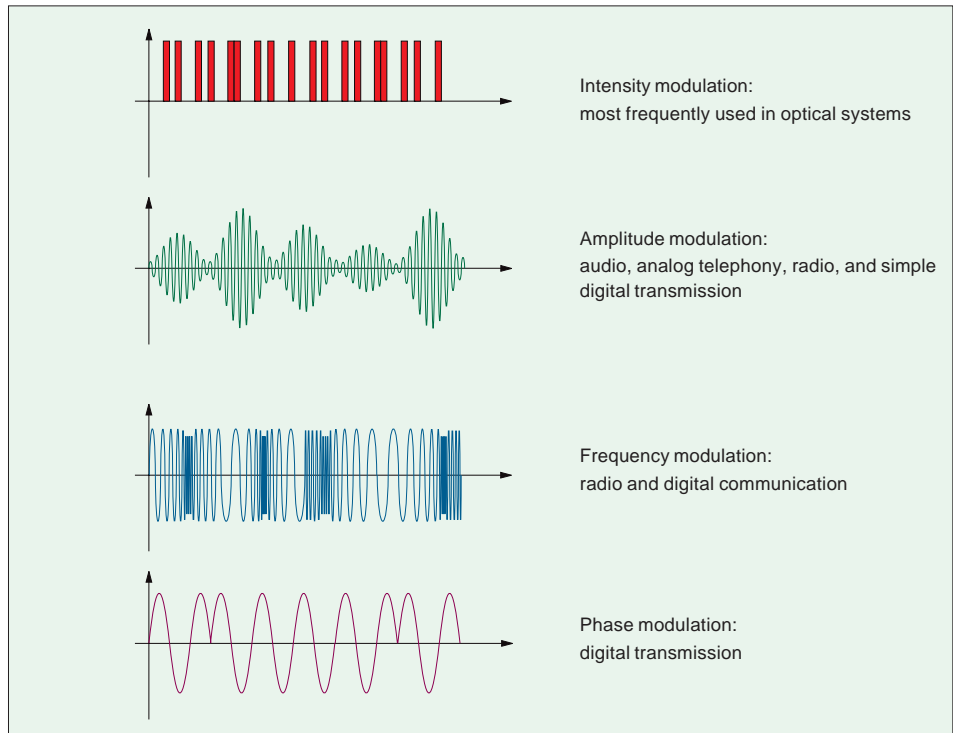

Fig. 6-34 Different types of modulation used in information transfer.



# Chapter 7

## Optical detectors

### Introduction

Optical detectors – photodiodes – perform functions complementary to those performed by laser diodes and LEDs. In an optical detector, optical energy is transformed into electric energy. The electric signal can then be amplified using ordinary electronics. Detectors made from a variety of types of semiconductor material have shown themselves to be highly suited to use in fiber optic systems. The three types of photodiode that are dealt with in this chapter are the p-n photodiode, the PIN photodiode and the avalanche photodiode (APD).

The trend in fiber optic communications development has been to move from shorter to longer wavelengths, and this trend is also reflected in the developments in optical detectors. This has meant the use of other types of semiconductor material: silicon is used for 850 nm, and germanium (Ge) and InGaAs for wavelengths in the range 1300 - 1600 nm.

The previous chapter described in detail how light emission can be induced through the excitation of electrons with electric energy, creating electron-hole (e-h) pairs. During recombination, (very precise) quanta of light are emitted, either through spontaneous emission or stimulated emission. In a photodiode, the opposite process occurs. The photodiode utilizes the fact that photons with an optical energy greater than the energy gap can cause electrons to jump from the valence band to the conduction band, i.e., absorption (see Figure 7-1).

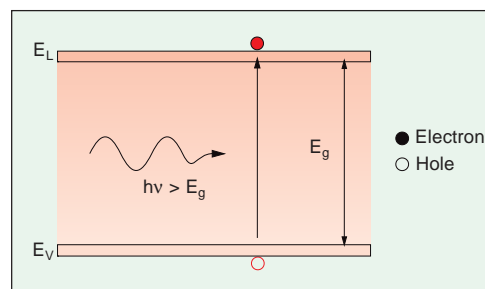

Fig. 7-1 Incident light with an energy of  $h\nu > E_g$  excites an electron and causes it to jump from the valence band to the conduction band, thereby creating an electron-hole (e-h) pair.

During recombination, (very precise) quanta of light are emitted, either through spontaneous emission or stimulated emission. In a photodiode, the opposite process occurs. The photodiode utilizes the fact that photons with an optical energy greater than the energy gap can cause electrons to jump from the valence band to the conduction band, i.e., absorption (see Figure 7-1).

If an external voltage is applied to the photodiode, these electron-hole pairs will flow through the semiconductor, thus creating an electric current through the photodiode that is proportional to the intensity of the absorbed light.

### Photodiode, p-n type

A photodiode that consists solely of a p-n junction represents the simplest type of photodiode. This type is used very infrequently in fiber optic systems, but is described here because it serves to illustrate the basic functional principles of a photodiode.

Figure 7-2 shows a p-n photodiode. As can be seen in the illustration, the photodiode has only a p-layer and an n-layer. When a negative bias voltage is applied over the diode (negative pole to the p-layer) the electric field creates a depletion region in the junction area between the p-layer and the n-layer. The charge carriers (free electrons and holes) will thus leave the junction area, which - now depleted of charge carriers - will have very high resistance. The largest voltage drop also occurs in this region, and the electric field strength is high.

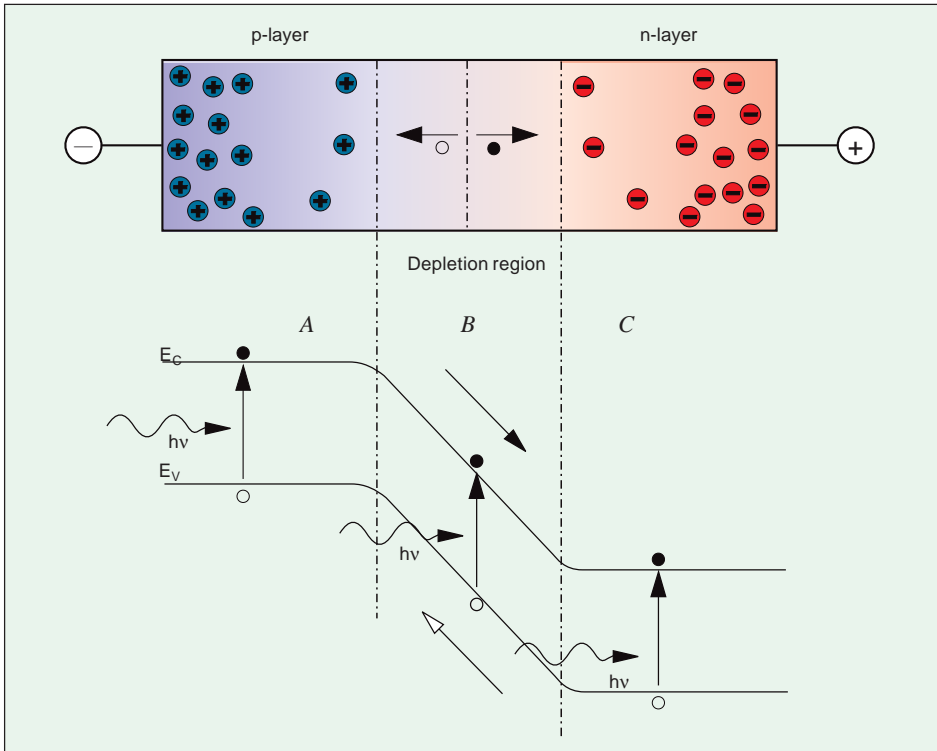

Fig. 7-2 An incident photon can cause the production of e-h pairs in three different regions (A, B and C) in the p-n diode. However, rapid detection is only achievable in B, the depletion region.

An incident photon with an energy greater than the energy gap between the valence and conduction bands will create an e-h pair. Electron-hole pairs can be formed in three different regions in the p-n diode. In Figure 7-2, the three regions are marked A, B and C.

In the region marked A, an incident photon creates a hole and a free electron. Because of the electric field created by the reverse voltage, the electron will “slowly” drift toward the depletion region and then over it, creating a charge flow. The electron will reach the depletion region if it was created less than the diffusion length from the depletion region. The diffusion length is defined as the distance that a minority carrier moves before it recombines. The corresponding conditions apply to the free holes created in the C region. The drift over the A and C regions is so slow that manufacturers of photodiodes strive to achieve a design with minimized detection in these regions.

If, however, the photon creates an e-h pair in the depletion region (B), the created electron will drift rapidly toward the n-layer and the hole will drift rapidly toward the p-layer. This rapid movement is due to the high electric field strength



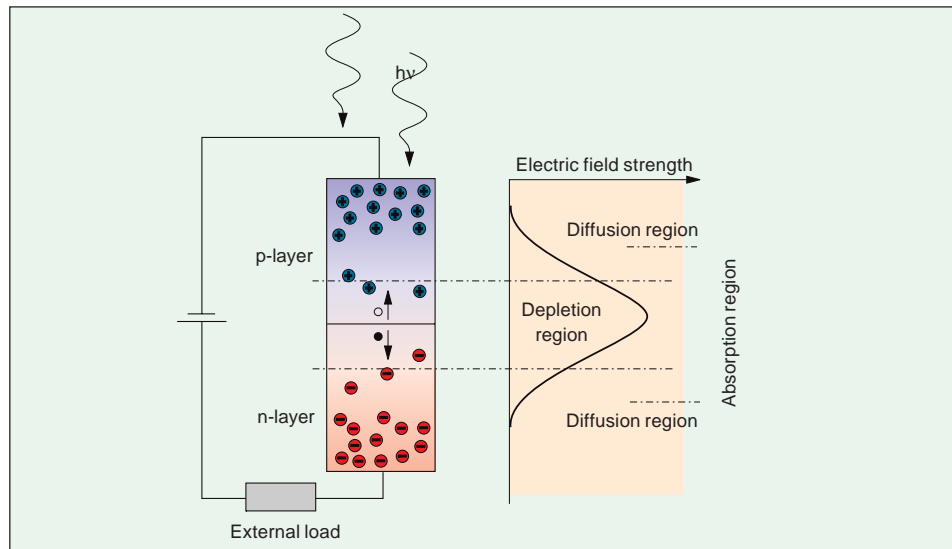

Fig. 7-3 Schematic description of field strength variations in a p-n diode. Reverse voltage and external load applied.

in this region. The flow of charge carriers creates an electric current through the connected circuits.

As pointed out above, the diffusion process in regions A and C is relatively slow and the movement of charge carriers toward the depletion region may continue even after the irradiation with photons has ceased. This is termed “slow tail response”. By applying a very lightly doped region between the p-layer and n-layer, called an intrinsic region, and making the p-layer thin and virtually transparent, the production of e-h pairs can be limited almost exclusively to the depletion region B. The resulting construction - called PIN diode - is much more efficient than the simple p-n diode.

## PIN diode

The p-n diode is fully sufficient for the detection of visible light, but for the detection of infrared light (longer wavelength), another type of photodiode has been developed. Light with longer wavelength penetrates further into the p-layer than

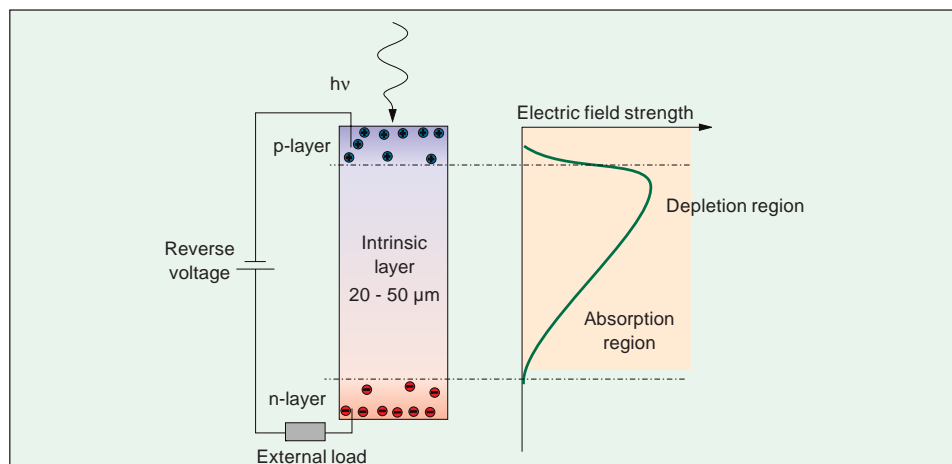

Fig. 7-4 By applying an intrinsic layer between the p- and n-layers, the absorption region obtained is much broader than that of a p-n diode.

short-wavelength light. One solution might be to make the layer of p-material thicker, but then many e-h pairs would recombine in the p-layer without creating a flow of charge (current). Instead, a relatively thick layer of lightly p-doped semiconductor material is applied between the p-layer and the n-layer - see Figure 7-4. The PIN diode is very suitable for the detection of light with wavelengths longer than those of visible light.

The intrinsic layer, or i-layer, has almost no free charge carriers, which means that its resistance is high and that the electric field in this i-layer is very strong. The characteristics of the i-layer allow the depletion region to take up a relatively large part of the photodiode. Thus, most e-h pairs are produced in the depletion region, which makes for a strong current through the circuit and faster response to the incident light.

Figure 7-5 shows a front-illuminated silicon PIN diode as an example of a photodiode design. This type of photodiode is used primarily for wavelengths in the range 0.8 - 0.9  $\mu\text{m}$ . A metal ring functions as the negative pole. Under this pole is a thin p-layer, and under the p-layer is a 20 - 50  $\mu\text{m}$  thick i-layer. The i-layer is made as thick as possible so as to achieve high quantum efficiency. However, there is a limit to how thick this layer can be before the response time will begin to increase. With the thickness given here, the response time is around 1 ns, and the dark current (see below in this chapter) is less than 1 nA.

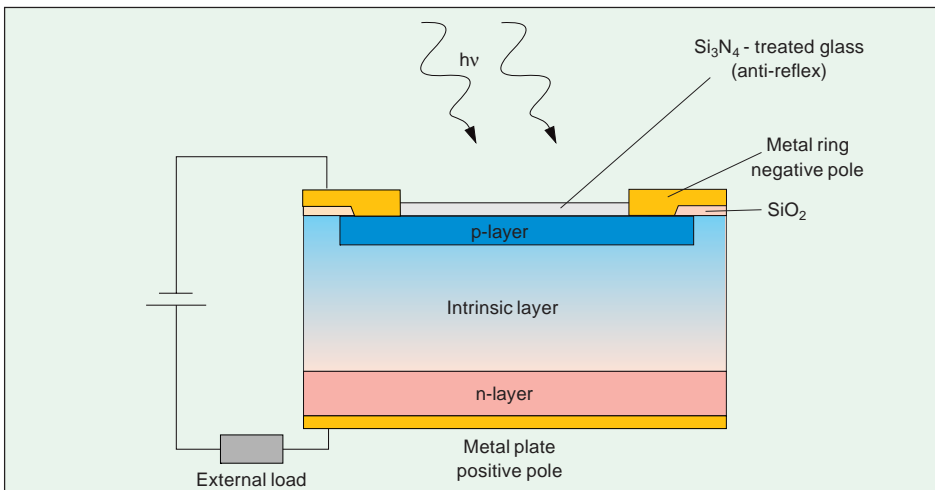

Fig. 7-5 The three layers of a front-illuminated PIN diode.

More recently, material combinations other than those containing silicon and germanium have been used. For the longer wavelength range of 1.3 - 1.55  $\mu\text{m}$ , manufacturers have used combinations of InGaAsP on a substrate of InP, or GaAlAsSb on a substrate of GaSb. Figure 7-6 shows how a photodiode is constructed according to the first-mentioned combination. A diode so designed has a dark current of less than 0.2 nA; its quantum efficiency is better than 60 % and the response time shorter than 100 ps. The layers marked  $n^+$  and  $p^+$  are the regions containing high-doped semiconductors, and those marked n and p are the intrinsic layers.

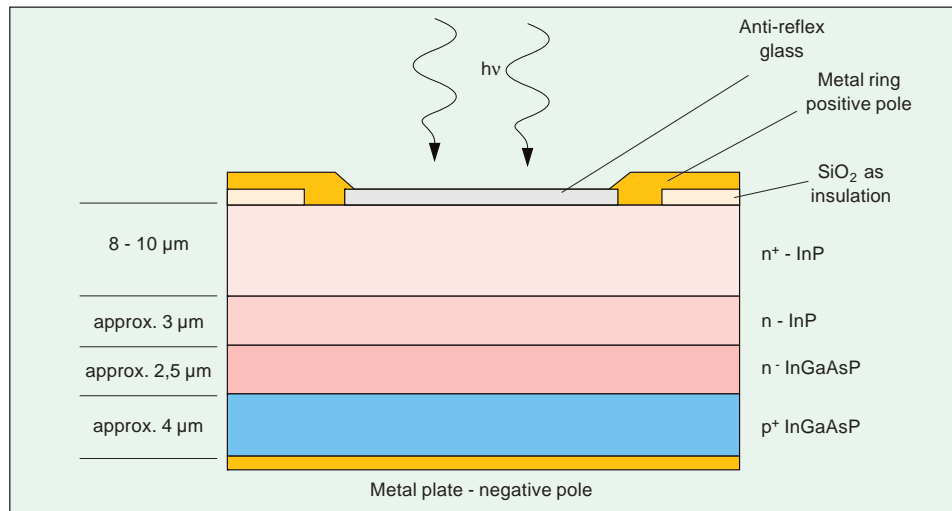

Fig. 7-6 PIN diode for longer wavelengths. Semiconductor materials: InP and InGaAsP.

## Avalanche photodiode

In an ideal PIN diode, each incident photon would create an e-h pair, which means that an electron would move from the positive to the negative pole. One could call the PIN diode an inverted LED, where virtually every excited electron corresponds to a photon. The equivalent of a laser diode would then be the avalanche photodiode (APD), in which each incident photon results in a large number of charge carriers which in turn cause a similarly strong current of electrons to flow through the external circuit.

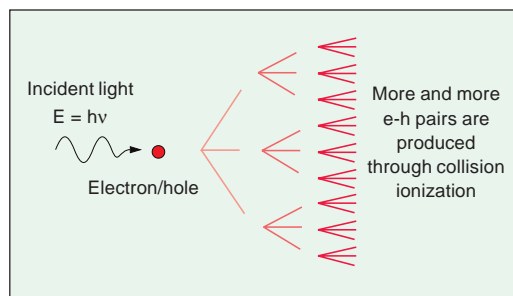

Fig. 7-7 A high reverse voltage of 100-300 V gives the electrons such high kinetic energy that multiplication of e-h pairs occurs through collision ionization.

Through a considerable increase of the reverse voltage over a p-n junction, the field strength can become so great that the charge carriers accelerating in the field gain sufficiently high kinetic energy to dislodge other electrons from the valence band and still pass through the depletion region. The e-h pairs thus produced can, in turn, cause new electron-hole pairs. In this way, the original charge carrier multiplies itself (see Figure 7-7).

This multiplication, or avalanche effect, has given rise to the name “avalanche photo diode”. The multiplication factor is very strongly dependent on the reverse voltage. A multiplication factor of 70 - 100 is common, which means that one photon results in an average flow of 70 - 100 electrons in the outer circuit. The signal-to-noise ratio is also significantly improved through photomultiplication.

The reverse voltage determines the multiplication factor, because a sufficiently strong electric field must be generated (see Figure 7-8) to create the avalanche effect. At a certain threshold value (several hundred volts) of the reverse voltage, electron-hole pairs will form without the diode being struck by any light. In an

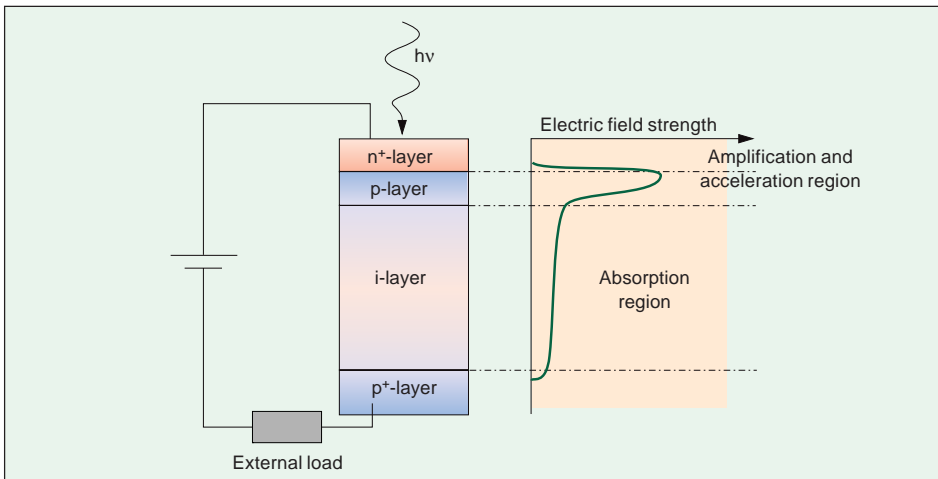

Fig. 7-8 Example of the distribution of field strength in an APD among the different layers.

effectively functioning circuit with an APD, the reverse voltage will lie just under this threshold value, so that even very weak optical radiation will result in a current in the photodiode (detection), i.e, a highly sensitive detector of optical radiation.

The disadvantage of an APD circuit compared to a common PIN diode circuit is the need for a reverse voltage over 100 V. A typical value for a silicon APD is 200 V, but for an InGaAsP APD a voltage as low as 10 - 50 V is sufficient.

Figure 7-9 shows a reach-through avalanche diode (RAPD) as an example of an APD. Uppermost is a metal ring that functions as the positive pole. A silicon dioxide ring functions as an insulating layer to the doped materials. Light penetrates through a high-doped n-layer of InP. The p-region consists of a low-doped p-layer of InGaAsP, an intrinsic layer of InP and a final high-doped p-layer of InGaAsP.

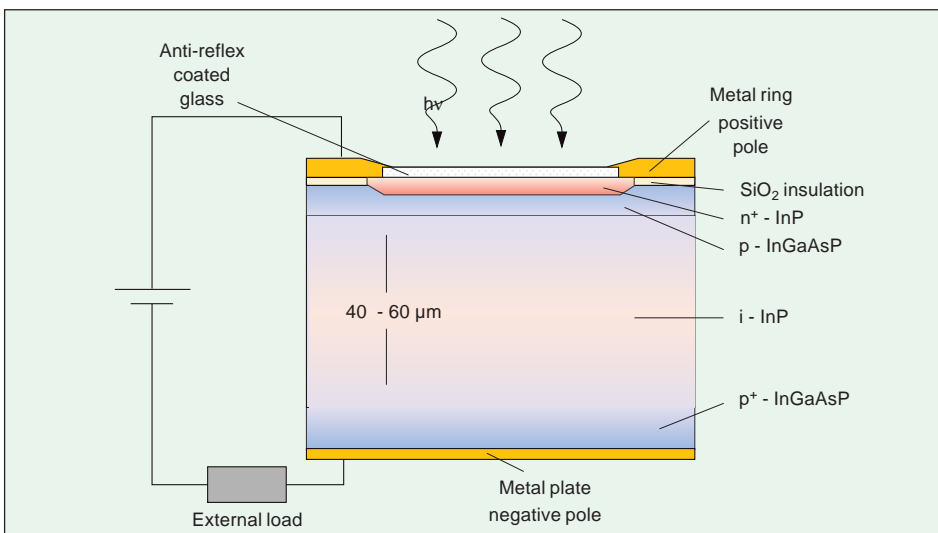

Fig. 7-9 Construction of an RAPD.

## Parameters affecting the detection of a light pulse in fiber optic systems

How a light pulse is detected by an optical receiver depends on several parameters:

- The intensity of the light pulse
- The distortion of the light pulse
- The receiver sensitivity

The signal strength together with the noise sources of the receiver gives a certain signal to noise ratio (SNR) of the usually digital signal. Unlike an analog receiver, a decision circuit then decides whether the received signal is a “one” or a “zero”. The final quality measure of the digital signal is the bit error rate (BER), i.e. what fraction of the transmitted bits that were correctly interpreted at the receiver.

### Intensity of the light pulse

During the light pulse’s propagation in the fiber link, its intensity is successively diminished by:

- Loss in the fiber [dB/km]
- Losses in each splice [dB]
- Losses in each connection [dB].

The output power is the input power reduced by the sum of all losses. The intensity of the light pulse can be given in W, mW, or  $\mu$ W. Another common way to express light intensity is in dBm, i.e. the light intensity in relation to 1mW.

### Distortion of the light pulse

The pulse is not only directly decreased in intensity by the attenuation of the fiber. The pulse also suffers from dispersion, the effect that different wavelengths of the light (or different modes in the fiber) travel with different velocities in the fiber. This will smear out the pulse in time, and is thus also a source of signal loss.

### Receiver sensitivity

The receiver sensitivity in turn depends on many parameters:

- The quantum efficiency and detector responsivity
- The receiver noise
- The bandwidth of the receiver

### Quantum efficiency ( $\eta$ )

An important part of the detection process is how many photons actually generate e-h pairs. If the number of e-h pairs produced is divided by the number of incident photons, a measure called the quantum efficiency is obtained. A quantum efficiency of  $\eta = 0.8$  means that for every ten incident photons, eight e-h pairs are

formed. The quantum efficiency describes only the number of primary-produced e-h pairs, i.e., not those produced after photomultiplication in an APD.

### Responsivity

By measuring a photodiode's electric output power and dividing this value by the power of the incident light, a measure of the photodiode's responsivity ( $R$ ) is obtained. The responsivity is measured in amperes/watt; a good quality PIN photodiode can have  $R = 0.7$  A/W. Incident light with a power of 20 mW thus causes a current through the diode of 14 mA. An APD can have  $R = 80$  A/W, which is more than 100 times higher.

The responsivity can be calculated by means of the quantum efficiency:

$$R = \frac{\eta \cdot e \cdot \lambda}{h \cdot c}$$

Formula 7-1

where  $e$  is the electron's charge ( $1.602 \times 10^{-19}$  [As]),  $h$  is Planck's constant ( $6.625 \times 10^{-34}$  [Js]) and  $c$  is the velocity of light. If you look at the formula, you can see that  $R$  is a function of the quantum efficiency and wavelength.

The responsivity is both wavelength- and material-dependent. In Figure 7-10,  $R$ -curves for three of the most frequently used materials are shown. Silicon is used for the first optical window at 850 nm. Germanium and InGaAs are used for the second and third windows, 1310 nm and 1550 nm, respectively.

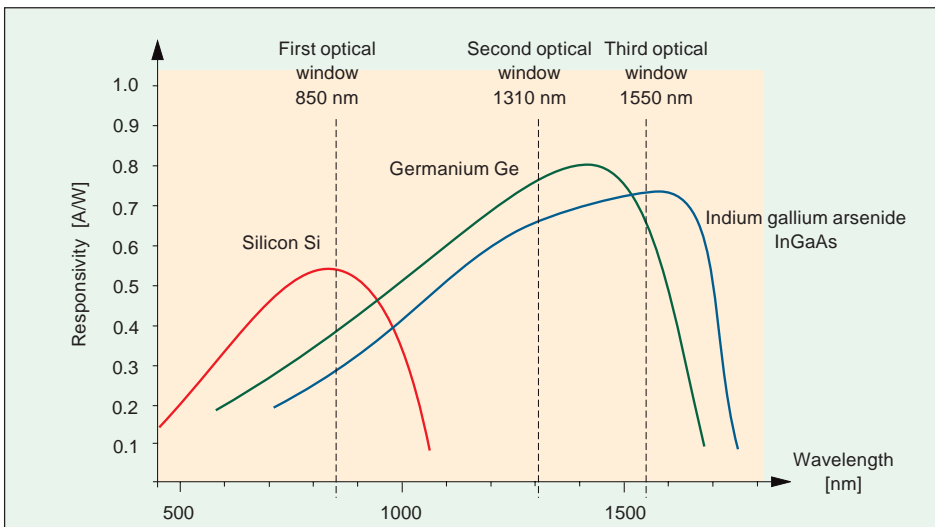

Fig. 7-10 The responsivity of a photodiode is dependent both on the wavelength of the incident light and the materials used.

### Coupling the fiber to the detector

When the fiber is coupled to the detector, some losses may occur through mismatching in the numerical aperture and diameter. Since the surface of the detector is usually much larger than the radiating surface of the optical fiber, the coupling losses are negligible.

But, if the  $\varnothing_{\text{det}} < \varnothing_{\text{fiber}}$ , the loss in dB is:

$$\text{loss}_{\text{diam}} = 10 \log_{10} \left( \frac{\varnothing_{\text{det}}}{\varnothing_{\text{fiber}}} \right)^2$$

Formula 7-2

and if the  $\text{NA}_{\text{det}} < \text{NA}_{\text{fiber}}$ , the loss in dB is:

$$\text{loss}_{\text{NA}} = 10 \log_{10} \left( \frac{\text{NA}_{\text{det}}}{\text{NA}_{\text{fiber}}} \right)^2$$

Formula 7-3

## Receiver noise

Noise is the term used to describe all forms of false or undesirable signals which mask and impede the detection of the actual signal in a fiber optic (non-specific) communication system. Here, noise is generated primarily by spontaneous changes at the atomic level, while in electric systems it is first and foremost of electromagnetic origin. In a fiber optic system, primarily two types of noise occur:

- Thermal noise
- Shot noise or quantum noise

### Thermal noise

Thermal noise stems from thermal interaction between free electrons and vibrating ions in the conducting material. At room temperature, thermal noise is the dominant noise source in the resistance of electric circuits.

Thermal noise, which causes a noise current in the photodiode, can be calculated using the formula:

$$i_{\text{tn}}^2 = \frac{4 \cdot k \cdot T \cdot B}{R_L}$$

Formula 7-4

where  $k$  is Boltzmann's constant ( $1.38 \times 10^{-23}$  J/K),  $T$  is the absolute temperature in Kelvin,  $B$  is the receiver bandwidth and  $R_L$  is the load's resistance.

### Calculation example

Consider a photodiode with an external load  $R_L$  of 400 ohm. The bandwidth is 15 MHz and the temperature is 320 K.

$$i_{\text{tn}}^2 = \frac{4 \cdot k \cdot T \cdot B}{R_L} \Rightarrow$$

$$i_{\text{tn}}^2 = \frac{4 \cdot (1.38 \cdot 10^{-23}) \cdot 320 \cdot (1.5 \cdot 10^7)}{400} = 6.624 \cdot 10^{-16} \text{ [A}^2\text{]}$$

$$i_{\text{tn}} = 25.7 \cdot 10^{-9} \approx 26 \text{ nA}$$

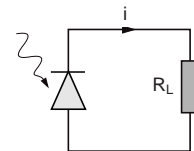

### Shot noise or quantum noise

As described in the chapter on laser diodes, the transmitted light behaves according to the rules of quantum mechanics, and the energy in the light is described by  $E = h\nu$ . The detection of a photon in a photodiode is a discrete process, the intensity of which is dependent on the number of e-h pairs produced. This means that the current in the external circuit will not consist of a continuous stream of electrons: these will be freed every so often (shots) in a discrete process. The current varies in proportion to the number of freed e-h pairs.

Shot noise is calculated using the formula:

$$i_{\text{sn}}^2 = 2 \cdot q \cdot i \cdot B$$

Formula 7-5

where  $q$  is the electron's charge ( $1.6 \times 10^{-19}$  Coulomb),  $i$  is the average generated current (signal current and dark current) and  $B$  is the receiver bandwidth. As the formula shows, shot noise increases the current with increased signal current and bandwidth. A certain amount of shot noise - called DC leakage current - occurs even in total darkness.

#### Calculation example

Typical values for a photodiode are:

dark current  $i = 3 \text{ nA}$  and a bandwidth of  $15 \text{ MHz}$

$$i_{\text{sn}}^2 = 2 \cdot q \cdot i \cdot B \Rightarrow$$

$$i_{\text{sn}}^2 = 2 \cdot (1.6 \cdot 10^{-19}) \cdot (3 \cdot 10^{-9}) \cdot (1.5 \cdot 10^7)$$

$$i_{\text{sn}}^2 = 14.4 \cdot 10^{-21}$$

$$i_{\text{sn}} = 12 \cdot 10^{-11} = 120 \text{ pA}$$

### Dark current

Dark current is the current generated by charge carriers leaving the surface of the diode, and by the formation of e-h pairs in the material without it being illuminated. The current is caused by the fact that atoms and molecules are always vibrating, which may occasionally cause an electron to be freed. The dark current is temperature-dependent and increases by about 10 % per °C.

### Integrated optical detector/amplifier

One means of reducing noise and other performance-limiting factors is to mount the photodiode with an amplifier (specifically manufactured for this purpose). This construction is then encapsulated in a normal integrated circuit. The amplification factor of these amplifiers may be as great as 40 - 50 V/W. This means that an optical signal of 20 mW generates a voltage of 0.8 - 1 V.



## Bandwidth

The bandwidth for a photodiode is entirely dependent on how rapidly an incident photon results in a current through the diode. This is generally called the rise time of the diode and is measured as the time between 10 % and 90 % of full amplitude. The bandwidth is limited primarily by three factors:

- diffusion time for charge carriers generated in the p-region and n-region, respectively
- drift time for charge carriers through the depletion region
- the capacitance of the p-n junction in combination with the diode's series and load resistances.

The bandwidth for a first-order RC filter can be calculated using the rise time  $t_{rt}$  and the following formula:

$$B = \frac{0.35}{t_{rt}}$$

Formula 7-6

The bandwidth can also be calculated by using the time constant RC. Figure 7-11 shows a simplified diagram of the diode, here with  $R_i$  is the internal resistance,  $C_i$  is the internal capacitance and  $R_L$  is the external load .

$$B = \frac{1}{2 \cdot \pi \cdot R_L \cdot C_i}$$

Formula 7-7

The rise time  $t_{st}$  is thus:

$$t_{rt} = 2.19 \cdot R_L \cdot C_i$$

Formula 7-8

The calculation that gives the broadest bandwidth for the photodiode will be used in system calculation.

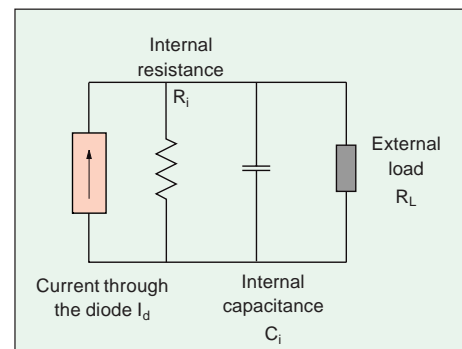

Fig. 7-11 Model of a PIN diode with internal resistance  $R_i$ , internal capacitance  $C_i$ , and external load  $R_L$ .

## Reverse voltage

Photodiodes require a reverse voltage. A PIN diode requires around 5 V, and an APD up to several hundred volts, which often means that an extra high-voltage power supply is required.

## Signal-to-noise ratio (SNR) and Bit Error Rate (BER)

In most signalling systems, the quality of the signal is indicated in relation to the signal-to-noise ratio (SNR). SNR is quite simply the average signal level divided by the average noise level.

$$SNR = \frac{S_{eff}}{N_{eff}}$$

Formula 7-9

Expressed in decibels, this gives:

$$\text{SNR} = 10 \cdot \log_{10} \left( \frac{S_{\text{eff}}}{N_{\text{eff}}} \right)$$

Formula 7-10

**Example:**

If the average signal level is 60  $\mu\text{W}$  and the noise level is 30 nW, the ratio will be 2000:1 or 33 dB.

A high SNR means that the signal is less disturbed by noise than if the SNR is low. Different applications require different signal quality, or SNR. A channel for audio transmission does not require as high an SNR as a television channel. In an optical link, the further the receiver is from the sender the less the SNR, since the strength of the signal decreases but the noise is constant in fiber, connectors, and any electric equipment used.

**Bit Error Rate (BER)**

In digital systems, SNR is generally replaced by a more useful expression, i.e., bit error rate (BER). BER is the number of erroneously detected digital bits per number of transmitted bits. A BER of  $10^{-10}$  means that one bit has been erroneously interpreted per 10 billion (thousand million) transmitted. For good quality systems, bit error ratios of  $10^{-9}$  -  $10^{-12}$  are common. As with SNR, different types of transmission require different transmission quality (low levels of BER). A digital audio channel can have a higher BER ( $10^{-7}$ ) than a data link BER ( $10^{-11}$ ). A few bit errors in audio transmission are not noticed, while a few erroneously transmitted bits can have catastrophic consequences in invoicing or order processing.

Generally, a high SNR gives a low BER (see Figure 7-12). In digital transmission, as in computer systems, there are sophisticated algorithms for error correction.

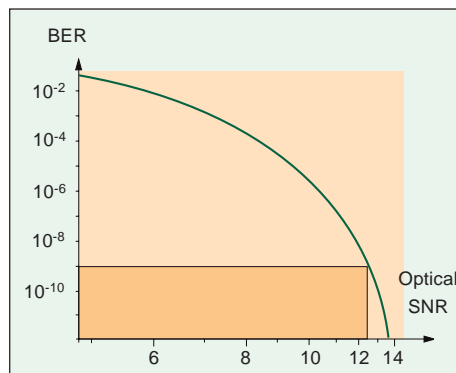

Fig. 7-12 Relationship between BER and optical SNR.

## Summary

- The most common types of optical detector for fiber optic communication are the PIN diode and the APD.
- The PIN diode is a relatively inexpensive component, while the APD requires more expensive, external circuitry with higher voltages.
- The APD can have over 100 times greater amplification due to photomultiplication. This can increase the dynamics of an optical link by 20 dB.
- Thermal noise and shot noise (or quantum noise) limit the dynamics and the sensitivity of the circuit.
- SNR and BER values are indicators of the quality of a system.
- The rise time (and thus bandwidth) of a photodiode is often determined by the RC filter formed by the load resistance and the photodiode's internal capacitance.
- Photodiodes can be mounted together with an amplifier in an integrated circuit.



## Chapter 8

# Optical fiber splicing

---

### Introduction

To link the different parts of a fiber optic communication system, it is necessary to splice and terminate optical fiber cables and connect transmitters and receivers. Rapid shifting between the various fibers in a cable is also necessary. Manufacturers generally produce cable in standard lengths; for example, 2, 4, 6 km. For this reason, when laying optical fiber cables for information systems it will always be necessary to join cable lengths to each other. Only for short distances of 2 - 6 km is it feasible to use only one cable length to cover the entire distance. Longer distances will consist of a number of cable lengths of 2 - 6 km each, which must be joined through some kind of splicing technique. The methods used result in two main groups of splices:

- Permanent splice
  - Fusion splicing (fibers melted together), which is the most common method of splicing fiber in long-distance networks
  - Mechanical splicing, which is primarily used in prefabricated networks for local installations

- Semipermanent splice

This type of splice is used primarily in networks where the subscribers move equipment around or where the entire network is being continually rebuilt, e.g., in local area networks (LAN).

The closer to the subscriber, the more complex the network structure becomes. The local networks of the future will contain countless permanent and semipermanent splices.

For long distances, amplification of the optical signal is usually required. This is done in amplifiers, called repeaters. In the traditional repeater, the optical signal is transformed into an electric signal which is amplified and “tidied up” and then retransformed into an optical signal. A new type of repeater is the erbium doped fiber amplifier, in which the optical signal is amplified through optical amplification in an erbium-doped fiber. The optical fiber cable is terminated with connectors at each repeater (amplifier); in each telephone exchange it is terminated in the cross connect panel (distribution frame).

This chapter describes optical fiber splicing, termination of optical fiber cable with connectors, and termination in telephone exchanges.

## Splices and connectors

Just like standard copper-based telecom networks, a fiber optic network requires splices and connectors. In a splice in a metal cable, the wires of the two cable ends are soldered or pressed together in order to form a joint with as low resistance as possible. Normally, the losses in such a joint are negligible. Connectors for metal cables have a similar function, but they must admit of being taken apart and put together again numerous times.

Making a splice in a fiber optic network involves getting two glass fibers with a diameter of 125  $\mu\text{m}$  to meet with an accuracy of a few thousandths of a millimeter or better. This matching can be achieved through a fusion process, or by making the fibers meet end to end with very high precision. Since 1980, connector and splicing techniques have been developed from laboratory level into being used by most of the major network engineering companies. Today's fusion splicer is almost completely automatic, and optical fiber cable is terminated with connectors by means of simple fixtures and pre-prepared material.

Installations to date have been primarily extensions of long-distance networks in most European countries, Japan, North America and Australia. As fiber optic technology begins to move ever closer to the subscriber, the networks will be constructed in the form of islands (LANs, cable TV and data networks, etc.) from different network engineering companies, using different types of materials and tools. In such a scenario it is very important that the interfaces between the islands be well-defined in terms of fiber dimensions, connectors and other equipment. This will facilitate future replacement of old equipment in conjunction with extensions and relocation of premises, or when - for a variety of reasons - certain parts of a network need to be bypassed.

### Requirements of splices and connectors

Today (1998), half a million telephone conversations can simultaneously pass through a fused or mechanical splice, or through an optical connector. To make this possible, stringent requirements are imposed on splices in fiber optic communications networks:

- Ease of installation. To terminate optical fiber cable with connectors, or terminating fibers, must be a simple process that can be carried out with relatively inexpensive tools and equipment, after only a short period of training.
- Low attenuation. A fiber optic network is a network with very low losses in the cable, and this must also apply to splices and connectors. Most fusion splices have a loss of less than 0.08 dB; the value for connectors falls below 0.5 dB.
- Good repeatability. It must be possible to screw a connector apart and together again many times without causing any noticeable increase in connector loss, despite a precision of within a few thousandths of a millimeter.
- Economical. A fusion splice costs less than 10 SEK (about \$1.50) but requires a large investment in tools. The price of a mechanical splice or connector is tenfold, but the tool costs are lower.

On account of these factors, the fusion splicing technique has come to be used mainly for long-distance networks, where demands for mechanical quality and low attenuation are particularly stringent. Mechanical splices are used mainly for indoor installations, such as LANs. Generally, a fusion splice is better than a mechanical splice, and similarly, an expensive connector will have lower loss than a cheaper one. It is, as always, a trade-off between quality and price. Most splices in future optical fiber networks, with fiber closer to the subscriber, will be fusion splices because of their low cost and high quality.

## Losses in a fiber optic link

This chapter only deals with losses related to splices. These losses fall into two categories:

- fiber-related losses
- losses related to the material in connectors and splices.

### Fiber-related losses

In the manufacture of optical fiber, certain deviations from the nominal values are permitted, because it is quite simply not possible to manufacture two exactly identical fibers. Tolerances are often in the vicinity of one thousandth of a millimeter, but even these small deviations contribute to losses during (fusion) splicing of optical fibers. In the chapter on the manufacture of fibers it was stated that an absolutely perfect fiber would still have its own minimum attenuation of around 0.16 dB/km theoretically and around 0.20 dB/km in production, at 1550 nm wavelength (due to a combination of Rayleigh scattering and IR absorption). Fiber-related losses are caused by the following factors:

- Mode field difference
- Different numerical apertures (NA)
- Different core diameters
- Different cladding diameters
- Non-circularity of core and/or cladding
- Core/cladding non-concentricity.

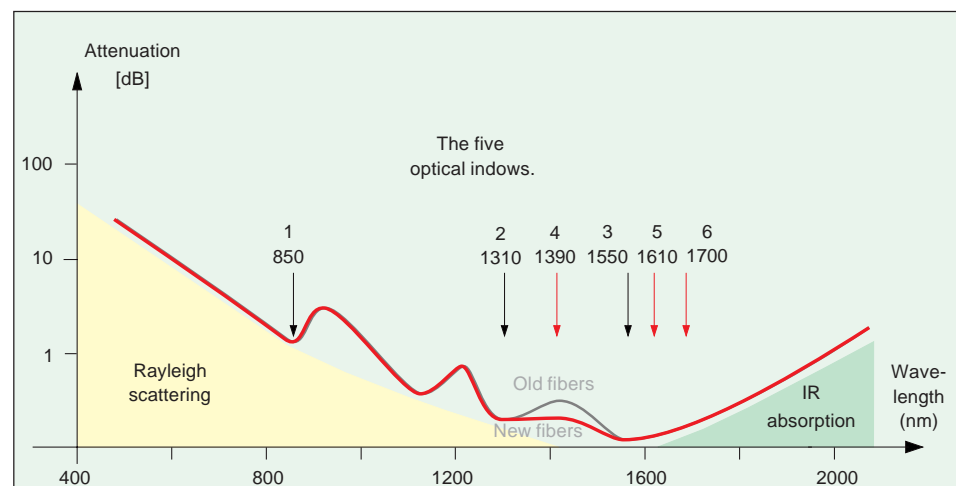

Fig. 8-1 Attenuation curve for silica optical fiber.

**Mode field difference**

If the diameter of the core of the transmitting fiber is different from that of the core of the receiving fiber, the mode field will become either wider or narrower. This will cause some attenuation of the light in both directions, which is sometimes experienced as an amplification of the signal in one direction when measured with an optical time domain reflectometer (OTDR), see Figure 8-2.

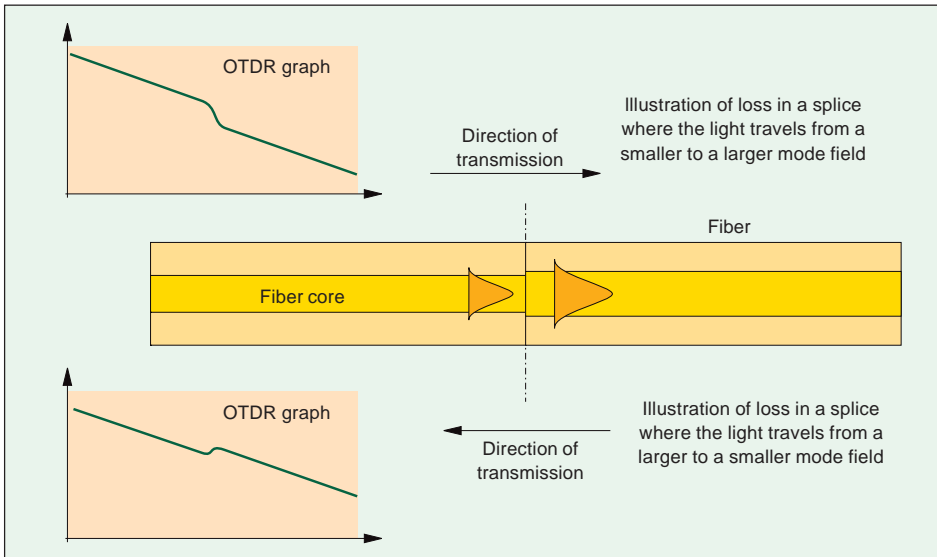

Fig. 8-2 Loss measurements in optical fiber networks - at splices between fibers with mode fields of different sizes - can give unexpected values.

**Different numeric apertures (NA)**

Losses occur when the transmitting fiber has a larger NA than the receiving fiber. The emitted light will be lost into the cladding of the receiving fiber (see Figure 8-3). When the  $NA_t$  of the transmitting fiber is larger than the  $NA_r$  of the receiving fiber, the loss is given by the following formula:

$$\text{Attenuation}_{NA} = 10 \log_{10} \left( \frac{NA_r}{NA_t} \right)^2 \quad \text{Formula 8-1}$$

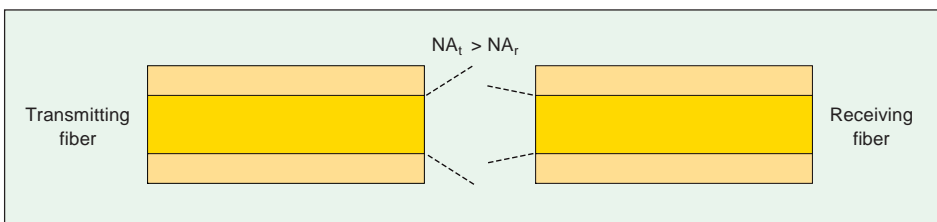

Fig. 8-3 Losses occur when the transmitting fiber has a larger NA than the receiving fiber.

**Different core diameters**

When the core diameter  $\varnothing_t$  of the transmitting fiber is larger than the core diameter  $\varnothing_r$  of the receiving fiber, losses occur because some of the light in the transmitting fiber's core is transferred to the cladding of the receiving fiber and is thus lost. Different core diameters also affect the mode field diameter (see Figure 8-2 and 8-4).



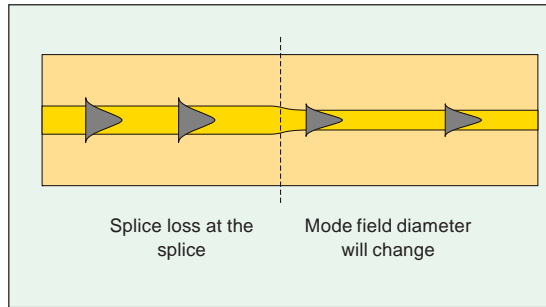

Fig 8-4 When fibers with different core diameters are spliced losses will occur and the mode field diameter of the lightpulse will change.

The loss due to the meeting of two different core diameters in a splice is given by:

$$\text{Attenuation}_\phi \text{ (multimode)} = -10 \log_{10} \left( \frac{\phi_r}{\phi_t} \right)^2 \quad \text{Formula 8-2a}$$

Where  $\phi_r$  and  $\phi_t$  are the core diameters of the jointed multimode fibers

$$\text{Attenuation}_\phi \text{ (single-mode)} = -20 \log \left( \frac{2 w_1 w_2}{w_1^2 + w_2^2} \right) \quad \text{Formula 8-2b}$$

Where  $w_1$  and  $w_2$  are the mode field diameters of the jointed single-mode fibers

### Different cladding diameters

In fiber manufacture, the tolerance (according to ITU) for the cladding diameter is  $\pm 2 \mu\text{m}$ . This means that a fiber with a diameter of  $123 \mu\text{m}$  may be spliced to a fiber with a diameter of  $127 \mu\text{m}$ . In fusion-splicing, the viscosity of the melted fibers ensures that they are relatively correctly aligned; but with a mechanical or semipermanent splice, such a difference can give rise to significant losses, especially for single-mode fiber (see Figure 8-5). The greatest loss occurs when two fibers with extreme differences meet. With a cladding tolerance of  $125 \pm 2 \mu\text{m}$ , the maximum loss is 1.4 dB. If the tolerance is lowered to  $125 \pm 1 \mu\text{m}$  (standard for serious manufacturer), the maximum loss is reduced to 0.7 dB. When cables containing single-mode fibers are terminated with connectors, the fibers and connectors are gaged (systematically tested) against each other to minimize losses caused by different cladding diameters as described above.

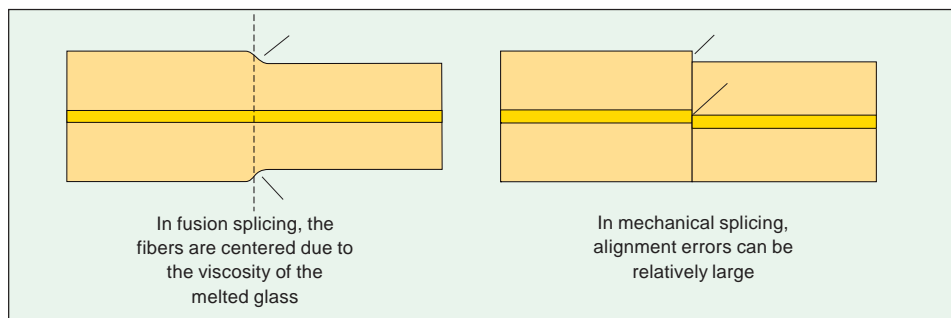

Fig. 8-5 Differences in core diameter have a greater effect on a mechanical splice than on a fusion splice.

### Non-circularity of core and cladding

Non-circularity of core and cladding can have the same effect as different core diameters. The effect is particularly obvious in semipermanent splices, where the connector does not have guiding slots, e.g., the SMA connector. Non-circularity will result in different loss values each time the splice is unscrewed and screwed

together again (see Figure 8-6), but it must be considerable to result in a marked loss increased.

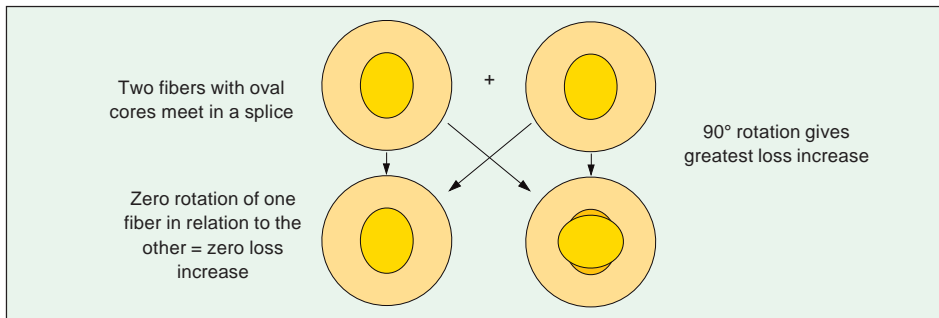

Fig. 8-6 Non-circularity of the core can affect the loss values for a splice. For connectors without guiding slots, this can mean different loss values after each disconnection/reconnection.

### Core/cladding non-concentricity

The core of an optical fiber should be located exactly in the center of the fiber; non-concentricity (see Figure 8-7) will cause splice losses.

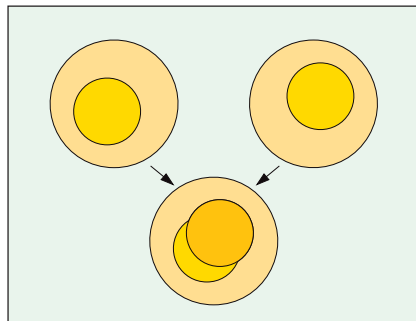

Fig. 8-7 Core/cladding non-concentricity can increase losses.

### Calculation example

Consider two multimode fibers with diameters of 62.5  $\mu\text{m}$  (transmitting fiber) and 50  $\mu\text{m}$  (receiving fiber), respectively. Their NAs are 0.25 and 0.15, respectively.

The attenuation due to the difference in numerical aperture is given by:

$$\begin{aligned} \text{Attenuation}_{\text{NA}} &= 10 \log_{10} \left( \frac{\text{NA}_r}{\text{NA}_t} \right)^2 = 10 \log_{10} \left( \frac{0.15}{0.25} \right)^2 = \\ &= 10 \log_{10} (0.6)^2 = 10 \log_{10} (0.36) = -4.43 \text{ dB} \end{aligned}$$

Attenuation due to the difference in core diameter is given by:

$$\begin{aligned} \text{Attenuation}_{\varnothing} &= 10 \log_{10} \left( \frac{\varnothing_r}{\varnothing_t} \right)^2 = 10 \log_{10} \left( \frac{50}{62.5} \right)^2 = \\ &= 10 \log_{10} (0.8)^2 = 10 \log_{10} (0.64) = -1.93 \text{ dB} \end{aligned}$$

The total loss through the splice when transmitting from the 62.5  $\mu\text{m}$  fiber to the 50  $\mu\text{m}$  fiber is around 6.4 dB.

## Losses related to connectors and splices

When two fibers are spliced, the splice will contribute somewhat to the attenuation of the signal through the fibers. This is minimized in a fusion splice between fibers that are thoroughly cleaned and precisely cut at right angles. Modern fusion splicers such as Ericsson's FSU 975, determine the cutting angle ( $90^\circ$ ) and the cleanness of the fiber before the fusion process is initiated. If all parameters are perfect, a fusion splice will not cause any measurable loss increase. The following connector- and splice-related errors apply primarily to semipermanent splices and mechanical splices, and - to a lesser extent - to fusion splices:

- radial misalignment
- longitudinal separation
- angular deviation
- vertex misalignment (applies primarily to PC-connectors)
- surface finish (semipermanent splices only).

To help the reader understand how these errors can occur, Figure 8-8 shows the main parts of a connector for optical cables.

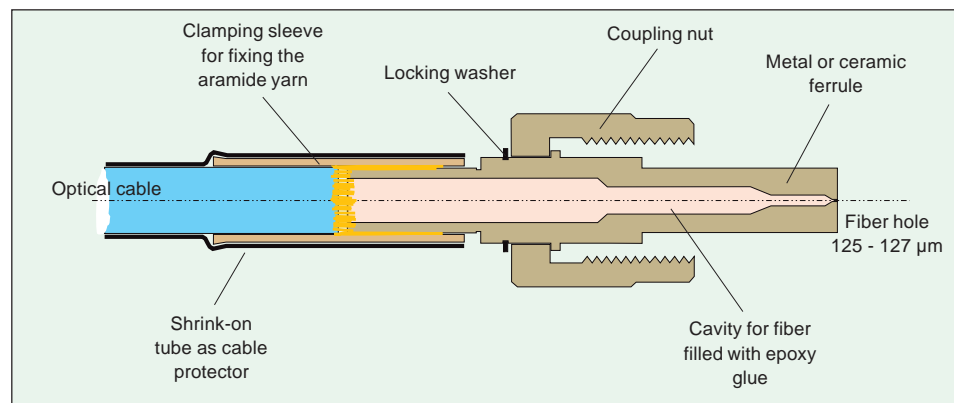

Fig. 8-8 An SMA connector in cross-section.

### Radial misalignment

A connector should be manufactured with great accuracy: the hole that the fiber is to pass through must be located exactly in the center of the ferrule. This hole should have the same diameter as the fiber, and the ferrule should have the same diameter as the coupling nut it is to be screwed into. The accuracy must be within 1 or 2  $\mu\text{m}$ . To eliminate differences between the fiber and fiber hole, each connector should be tested (gaged) against the fiber to be used. This is a time-consuming but necessary check. The radial error  $R_E$  is expressed in relation to the fiber's core diameter  $C_D$ .

From Figure 8-9 it can be seen that a 10 % misalignment results in a loss increase of approximately 0.5 dB. A 10 % misalignment for a single-mode fiber is no more than 1  $\mu\text{m}$ , which means that an accuracy of 0.5  $\mu\text{m}$  is required for each connector. A semipermanent splice between multimode fibers 62.5/125  $\mu\text{m}$  must have an accuracy of  $\pm 3 \mu\text{m}$  for the loss increase not to exceed 0.5 dB.

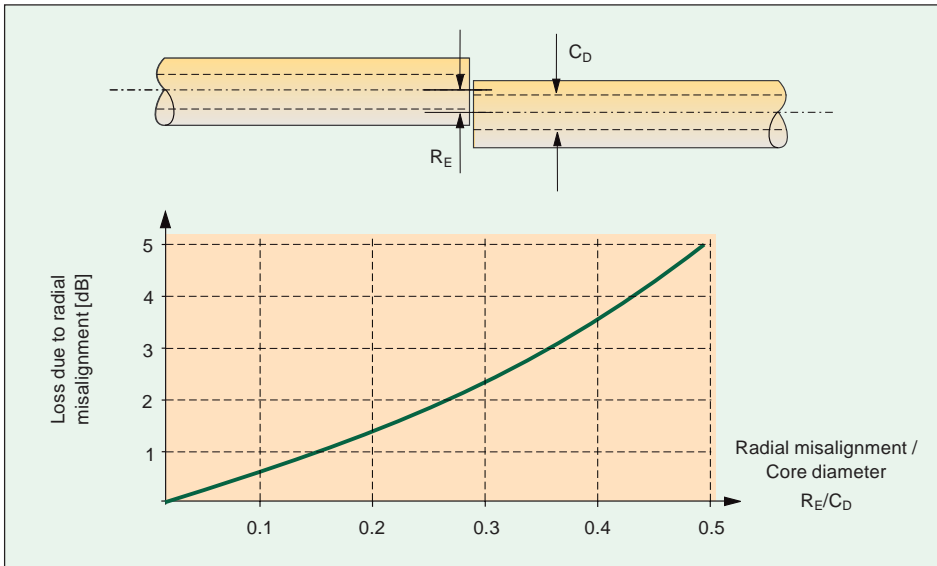

Fig. 8-9 Graph of loss through a connector with radial misalignment between the two fibers.

### Longitudinal separation

Some types of connector do not have spring loaded ferrules. To ensure the correct length, special fixtures are used when the ferrule's end surfaces are ground. Normally, the separation between the ends is a couple of  $\mu\text{m}$ , provided that the ferrule is not ground too much. Loss increases are directly related not only to the ratio of the longitudinal separation  $L_S$  to the core diameter  $C_D$ , but also to the fiber's numerical aperture. A large NA will result in larger loss increases than a small NA for the same longitudinal separation. Most modern connectors have a spring-loaded ferrule which means that the two ferrules will meet perfectly without the risk of damaging the fiber end (which was the case with the earlier LME and SMA connectors - see below in this chapter). Longitudinal separation also gives rise to Fresnel reflection at the end surface. This reflection is up to 4 % (-14 dB) if there is an air gap between the fiber ends. By using an oil with matching refractive index on the fiber ends, Fresnel reflection can be wholly or partially eliminated.

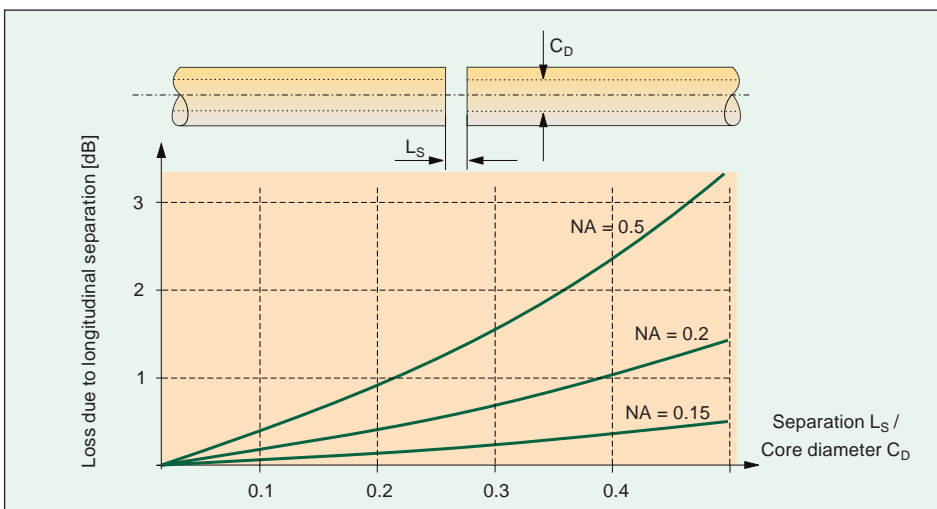

Fig. 8-10 Graph of loss caused by longitudinal separation.

### Angular deviation

As mentioned previously, the angle between the meeting fibers is an important factor in splicing. When the fiber is cut and subsequently ground, an angle of  $90^\circ$  to the fiber's longitudinal axis should always be aimed for. The meeting surfaces should therefore be parallel to achieve the lowest splice loss.

The loss increases with increased angular deviation. A small NA worsens the effect of angular deviation, while a large NA can compensate for this effect to a certain extent.

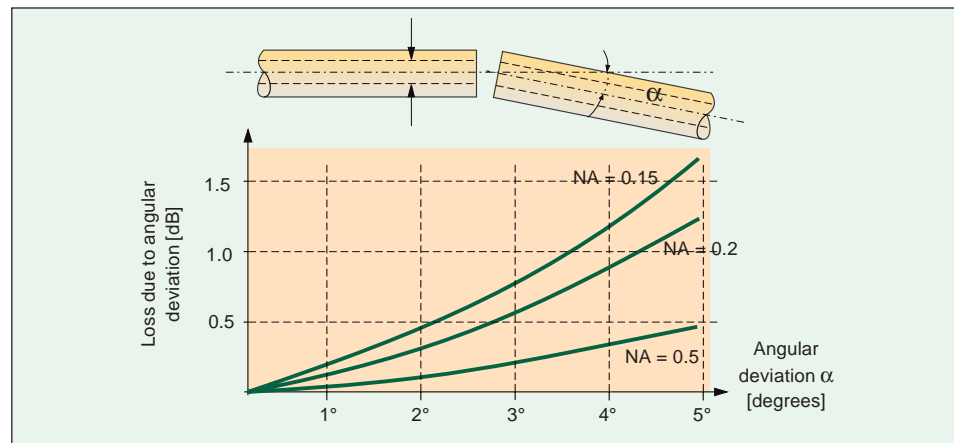

Fig. 8-11 Graph of loss caused by angular deviation between meeting fiber ends.

### Vertex and vertex misalignment

In a newer type of the FC-connector, the end surfaces of the ferrules are not only pressed gently against each other by springs but, to obtain the best possible transmission of light, (reduce reflexions) the ferrule's end surface is ground to a convex (hemispherical) shape, with a radius of curvature  $r_1$  (see Figure 12-12). This type of connector is generally called a PC connector (PC = physical contact).

There are currently two standard radii for the ground ends: 60 mm and 20 mm. FC/PC-connectors with a ferrule with 60 mm radius of curvature have existed for the longest time. However, experiments have shown that a radius of curvature of 20 mm results in better transmission, so the smaller radius is to be preferred. An additional advantage of the smaller radius is that temperature changes cause less

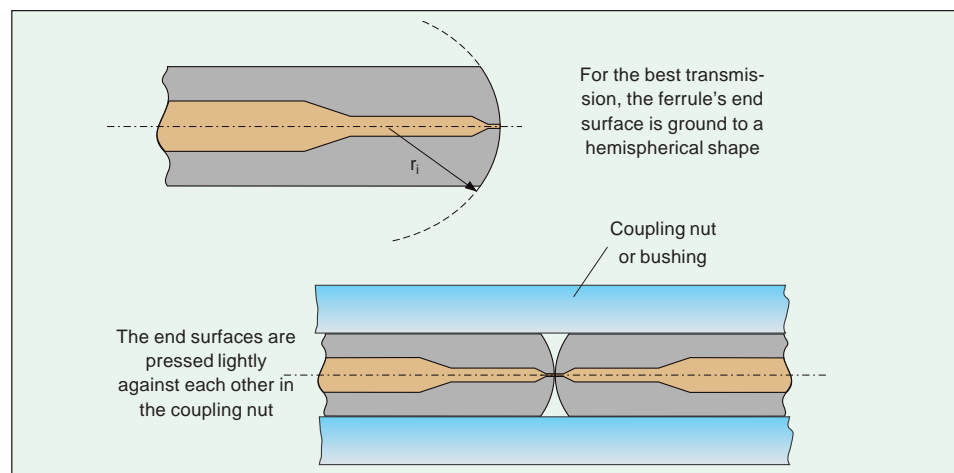
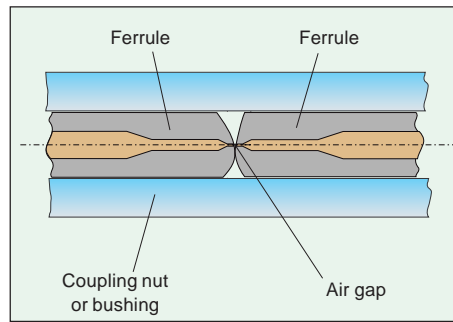

Fig. 8-12 The end surfaces of the PC connector's ferrules are ground to a hemispherical shape.

variation in reflection. On the other hand, a ferrule with a 20 mm radius of curvature is more sensitive to vertex misalignment.

Vertex misalignment is a form of displacement: the highest point on the ground ferrule is not at the exact center of the fiber. When the two connector parts are mated, an air gap will form between the ferrule ends (see Figure 8-13) at the fiber core with resulting losses (see Longitudinal separation above). If the width of the air gap is within the coherence length for the laser, the reflection loss may be as high as -8 dB!



*Fig. 8-13 If the mating parts of a PC connector are ground unevenly, an air gap may form between them. This air gap markedly reduces transmission for SM fiber when laser is used.*

### Surface finish

A process in steps of gradually increasing precision is used for the grinding of an optical connector. The first step removes any traces of glue, gives the ferrule its form, and adjusts the position of the vertex in relation to the fiber center. The subsequent steps polish the surface to remove any scratches and small cracks. Scratches and cracks in the fiber's end surface will reflect and disperse some of the light so that it cannot continue into the other ferrule end, resulting in increased connector loss.

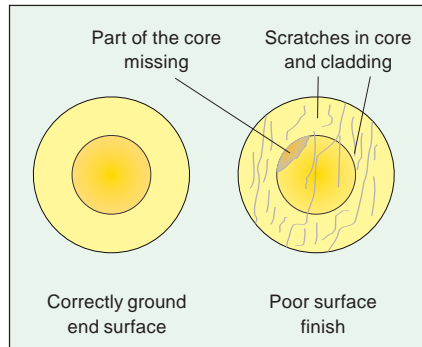

*Fig. 8-14 A poorly finished end surface results in increased splice loss.*

### Other causes of splice loss

Although it is recommended that the same type and make of fiber be used for an installation, it may sometimes become necessary to change the make and type and even the size of the fiber used. Normally, these changes have a detrimental effect on the final result. Factors which may be different are the NA, mode field diameter (core diameter) and cladding diameter.

### Fiber cleaving

Careful preparation of the fiber before making a mechanical splice or fusion splicing is decisive of the quality of the resulting splice. All the primary coating is stripped off by means of a special tool; the fiber is then washed with pure alcohol or isopropanol, and finally cleaved. The cleaved surface should form an angle of, ideally, 90° to the fiber's longitudinal axis. Modern fusion splicers have built-in programs to measure the cleaving angle. Deviations exceeding 1° are normally not permitted.



Fig. 8-15 The quality of the fiber cutter used can often determine the performance of a splice. A fiber cutter of high quality cuts the fiber rapidly and safely at a 90° angle, without deforming the cutting surface. The cutters above are from Sumitomo (left) and Ericsson (right). The Sumitomo cutter also cuts fiber ribbon.

## Fusion splicing of optical fiber

The most reliable method of splicing optical fiber is fusion. By heating clean, accurately cut fiber ends to their melting point, while simultaneously pressing them against each other longitudinally, the fibers will fuse and form a splice with very low loss (< 0.08 dB).

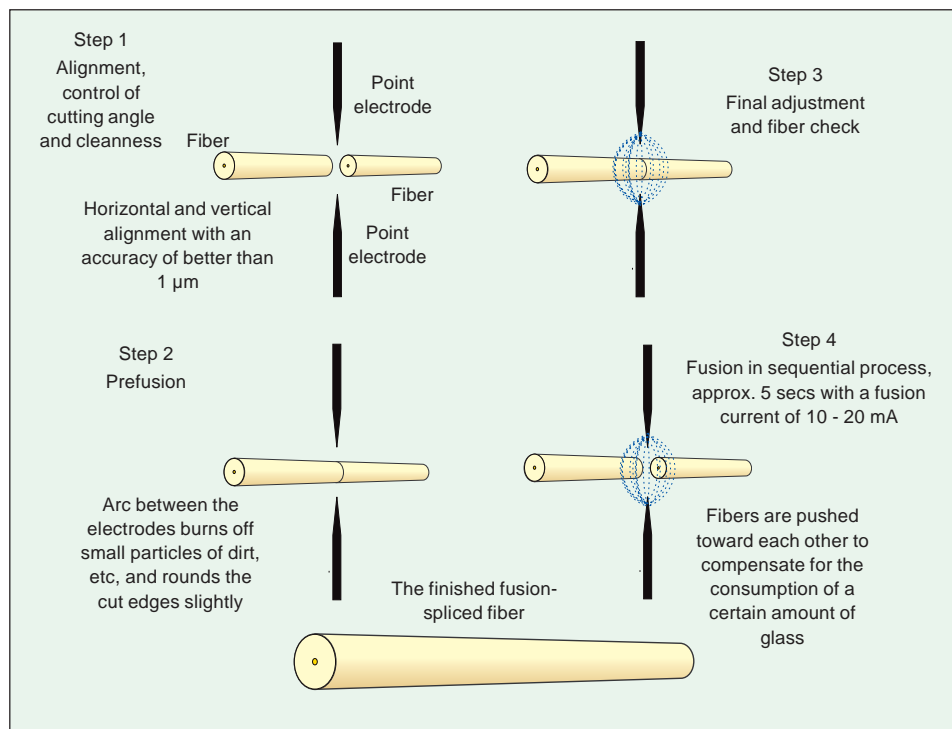

Fig. 8-16 Simplified illustration of the most important steps in fusion splicing.

## The fusion process

The fusion process is as follows: The fiber ends are positioned opposite each other, each fixed in a moveable V-block with magnetic closure. In the most modern fusion splicers, the entire process is automatic. By means of microprocessors, servo motors and advanced electronic scanning technology, the fiber ends are adjusted against each other with an accuracy of 1/10,000 mm. This alignment also involves controlling the angle of cut of the fiber ends, and their cleanness. The fiber ends are heated to their melting point with an arc between two point electrodes and then brought together to form a homogeneous splice.

In the fusion process, a number of electronic scan images are taken from which the quality of the splice can be assessed manually or through advanced mathematical analysis. After fusion, the splice is secured with a piece of plastic shrink-on tubing, often with a built-in plastic, ceramic or steel guiding pin.

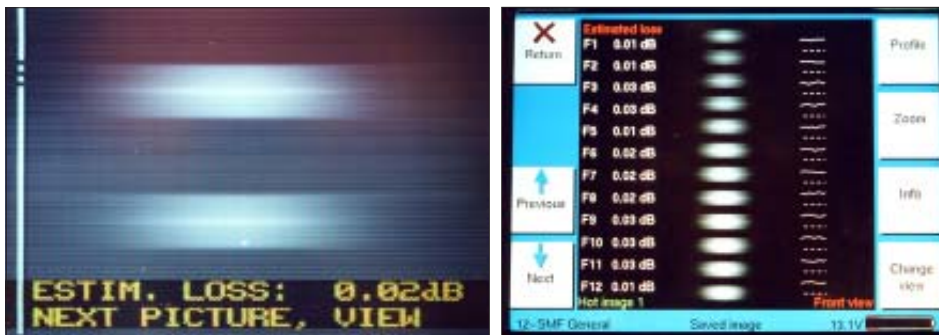

Fig. 8-17 Two electronically scanned images. The picture to the left shows a picture taken during the fusion process of a single fiber and the picture to the right shows the same for a 12-fiber ribbon splicer. The fiber core is visible as a light-colored stripe in the middle of the fiber (left picture only). This picture shows also the fiber in both horizontal and vertical direction. The picture with the 12-fiber ribbon is only in vertical direction.

## Fusion splicing of fiber ribbon

When splicing single fibers, the two fibers to be spliced can be positioned individually towards each other in x-y-z direction by electronically controlled motors. In a 2-, 4-, 8- and 12-fiber ribbon the fibers are locked to each other as the idea for fiber ribbon. This makes it not possible to individually align each fiber in x and y direction.

The bonding acrylate that holds the fiber together to form the ribbon is removed to about 40 mm from the fiber end. The stripped fibers are cleaned and cut as described for single fibers. The cutting of ribbonized fibers is even more vital for the final result as with the single fiber. All fibers must be cut at 90 degree angle and at exactly the same length. Length discrepancies of 1–2  $\mu\text{m}$  will make a less good splice.

The prepared fiber ribbon is placed in a V-groove matrix (Figure 8-18) that align all fibers in x and y direction. The fibers are heated to their melting point with an arc between the electrodes and brought together to form a homogeneous splice. The temperature must be equal for all fibers in the ribbon so that the outer and inner fibers are spliced with the same high quality.



In the fusion process for ribbon fibers, equal as for that of single fibers, a number of electronic scan images are taken from which the quality of the splice can be assessed manually or through advanced mathematical analysis. After fusion, the splice is secured with a piece of oval plastic shrink-on tubing, often with a built-in plastic, ceramic or steel guiding pin.

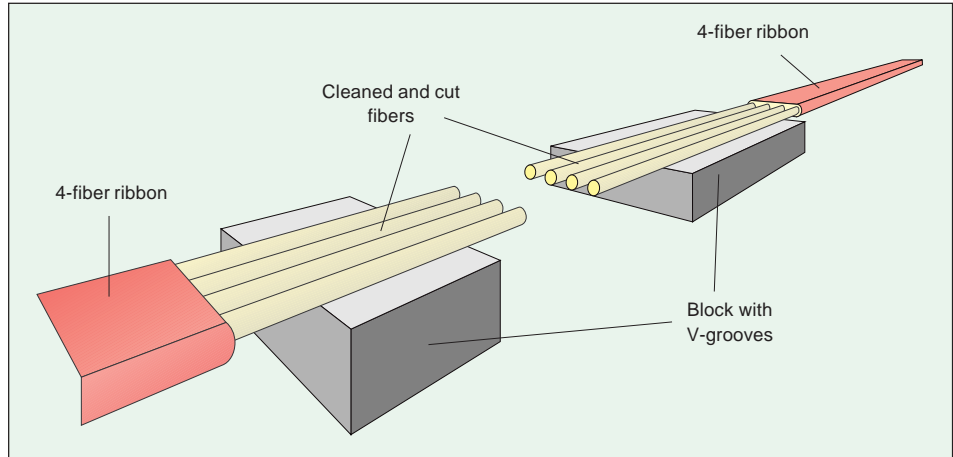

Fig. 8-18 The alignment in a fusion splicer for fiber ribbon uses V-grooves for x and y direction.

### Electronic image analysis

The electronically scanned images taken during the actual fusion process are analyzed mathematically. When the fiber is heated, the fiber core becomes visible (see Figure 8-17) as the lighter part of the fiber, which allows an operator to make a visual assessment of the quality of the splice. Special calculation programs based on curvature analysis of the fiber core give a rather accurate estimation of the splice loss. Figure 8-19 shows a number of errors that can occur when fiber is fusion-spliced. All these errors cause increased losses through the splice.

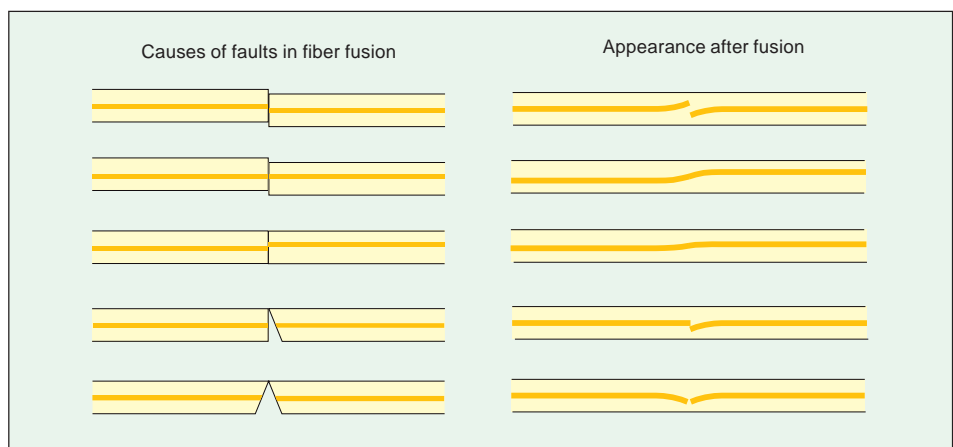

Fig. 8-19 The loss in a fusion splice can be affected by various parameters, such as cutting angle, poor alignment, or core/cladding concentricity.

## Mechanical splices

### V-block splice

The V-block is a simple form of a mechanical splice. A V-shaped groove is etched in a plastic block. The depth of the groove is such that when a plastic lid is placed over the block, with the fiber lying in the groove, the fiber is exposed to pressure from three directions (see Figure 8-20). The fiber ends are firmly pressed against each other and the lid is put on and fixed. If an oil with matching refractive index is used around the fibers, a low ( $< 0.2$  dB) splice loss can be obtained with this method. The V-block splice is used mainly for indoor installations and as a temporary (emergency) splice in long-distance networks.

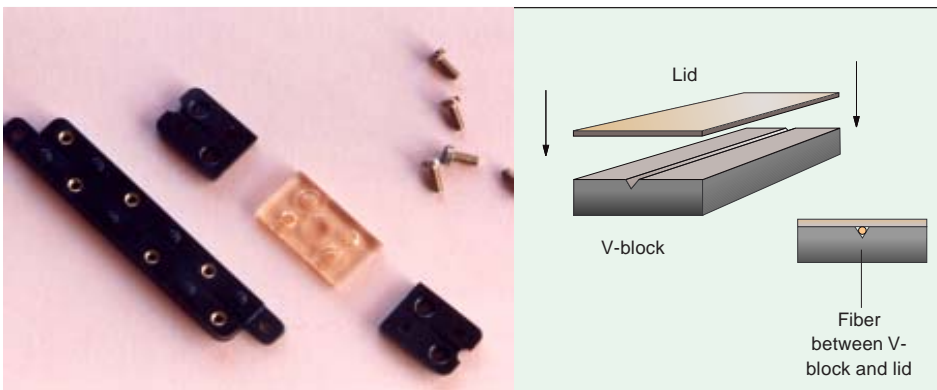

Fig. 8-20 V-block for simple mechanical splicing of optical fiber.

### Precision-drilled tubes

A number of different types of mechanical splice are based on the use of tubes. The two fiber ends meet inside some form of tube, often filled with an oil with matching refractive index. The splice is secured with curable epoxy glue (see Figure 8-21).

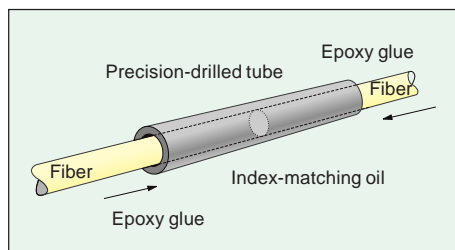

Fig. 8-21 The fibers are pushed from either end into a precision-drilled tube.

### Three-rod splice

The three-rod splice consists of three steel rods with a diameter such that when the rods are laid against each other lengthwise, the channel formed between them has exactly the same diameter as the fibers to be spliced (see Figure 8-22). Shrink tubing is used to hold the rods together. After an index-matching oil is injected, the cut fiber ends are pushed - from opposite directions - into the channel, thus forming a simple though

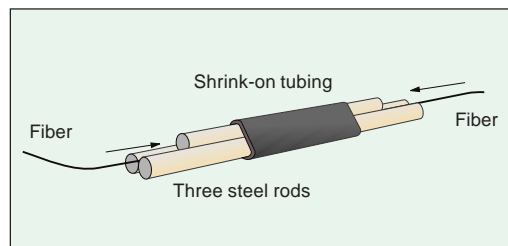

Fig. 8-22 A three-rod splice is quickly and easily made; it is often used in cable or fiber performance measurements.

not permanent mechanical splice. The three-rod splice is used primarily for various types of measurement where rapid connection of a laser or power meter is required. With index-matching oil, an average loss of around 0.2 dB can be obtained.



Fig 8-23 Three mechanical splices, to the left is the three rod splice, in the middle the Fiberlock® (3M) and to the right is the Fingersplice® (AMP).

### Fiber ribbon splices

A much more complex type of splice is required for mechanical splicing of cable of fiber ribbon. A common type of splicer is shown in Figure 8-24. Both ends of the fiber ribbons are cleaned and all primary and secondary coating stripped off. The fiber ribbon ends are then positioned opposite each other between two silicon plates, one of which has high-precision etched grooves. Before the two plates are fixed by means of a spring load arrangement, the fiber ribbons are pushed together end to end, and index matching oil is injected into the grooves. Several etched plates may be placed on top of each other to form a splicing matrix for multi-fiber cable with high packing density. Up to  $12 \times 12$  fibers can be spliced in this way. However, since 1992 such matrices have been more or less superseded by fusion splicers.

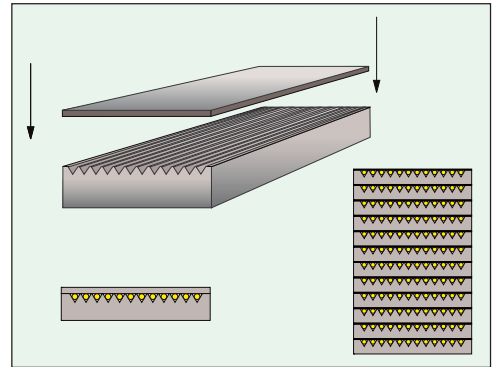

Fig. 8-24 A method of mechanical splicing of up to 12 fiber ribbons in a splicing matrix.

### Semipermanent splices

Quite different problems have to be solved in semipermanent splices. It must be possible to disconnect and reconnect a semipermanent splice many times without causing increased splice loss. This means that there are stringent requirements for mechanical precision and durability in the case of semipermanent splices, and this is particularly true of connectors intended for single-mode fiber.

The causes of faults in a semipermanent splice have been dealt with earlier in this chapter. A number of additional requirements may be mentioned:

- accurate concentricity
- effective protection against dust and moisture

- the splice must be capable of taking up longitudinal tensile stresses without causing increased loss
- it must be easy to attach the splice to an optical cable (even in field mounting)
- it must be easy to disconnect and connect the splice
- the splice must be durable.

In the market today, there are many different types of connectors, which can be divided into four categories:

- Cylindrical ferrule
- Conical ferrule
- Expanded beam
- Connectors for fiber ribbon.

## Connectors with cylindric ferrule

### The cylindrical ferrule

The most common and least expensive method of making a mechanical splice for optical fiber is to make the ferrule in the form of a steel or ceramic cylinder. The ferrule of one optical fiber cable is centered against the ferrule of the other optical cable in a cylindrical bushing (see Figure 8-25). The performance of this type of mechanical splice (several of which can be fitted in the field) is dependent to a large extent on the concentricity of the hole for the fiber through the ferrule and bushing. An average loss of 0.2 - 1 dB can be expected, depending on the shape of the end surfaces (plane or hemispherical).

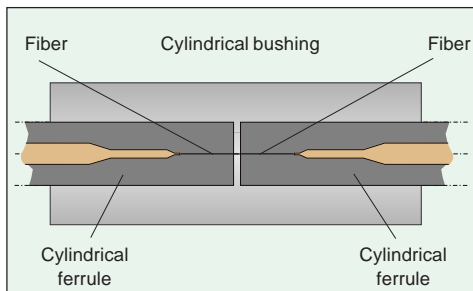

Fig. 8-25 Two splices with cylindrical, face-ground ferrule mounted in a bushing.

### LME connector

The LME connector, which is intended for use with multimode (MM) fiber, was designed and manufactured by LM Ericsson. At the time it was developed, there was no standard for MM connectors. The LME connector can be considered the predecessor of the SMA connector, since most of the dimensions and technical performance parameters are identical to those of the SMA. Unlike the SMA (which has become world standard), the LME connector has a guiding pin that forces the ferrule to take up the same position each time the connector parts are mated. The principal parts of the connector are shown in Figure 8-26.



Fig. 8-26 LME connector, one of the first connectors for optical fiber cable.

## SMA connector

The SMA connector was one of the first standard connectors for optical cables to be accepted by a large number of countries. The connector is only intended for use with MM fibers. The connector (shown in Figure 8-27) is cylindrical with a non-spring ferrule, the diameter of which is 3.174 mm. Because the ferrule is not spring-loaded, there must be an air gap between the two connector parts when they are screwed into the splice's bushing; otherwise there is a risk that they break when pushed against each other. The fibers are glued into the ferrule, which is then ground and polished. After polishing, the ferrule should be 9.808 mm long. This degree of accuracy is obtained by grinding the ferrule in a simple fixture. The cable's strength member (aramide yarn) is clamped by means of a metallic sleeve at the back edge of the connector. The SMA connector is highly suited to connection/disconnection in the field.



*Fig. 8-27 The SMA connector became an international standard. The figure shows one connector with ceramical ferrule and one with a metallic ferrule.*

SMA connectors are used primarily in data links, LANs, sensors and other equipment that uses MM fiber.

## FC connector

The FC connector was developed originally by Japan's NTT. Unlike the previously described connectors, the FC connector has a spring-loaded ferrule inside a cylindrical housing (see Figure 8-28). The ferrule has a diameter of 2.499 mm, which is somewhat smaller than that of the SMA connector's ferrule. The ferrule's end surface is face-ground, which has the disadvantage of resulting in reflection of light back toward the transmitter. The FC connector is therefore re-commended only for use together with transmitters that have an LED as the light source. The advantage of a spring-loaded ferrule is that the connector end surfaces can lie against each other and that the ferrule's length need not be within such narrow tolerances.



*Fig. 8-28 FC-FC/PC connector in bits and pieces. To the left is the mounting bushing to be fitted in the ODF box.*

## FC/PC connector

To reduce the reflection of light from the end surfaces, the FC connector was developed further. The ferrule's end surface was ground to a hemispherical shape

instead of plane (see Figure 8-29). The end was first ground to a radius of curvature of 60 mm, but to reduce reflection even more, the radius is now 20 mm, although both sizes still occur. For installations where the transmitter is a laser diode, the PC connector is always recommended because of its low level of reflection. The PC connector is also recommended for installations which are likely to change from an LED to a laser diode light source in the future.

Ferrules in FC and FC/PC connectors are made of either stainless steel with a ceramic capillary or they are completely ceramic. The latter type has certain advantages:

- Lower cost (not initially, but if the device is connected/disconnected frequently over a long period)
- Dependability. Ceramic is a hard material that is not worn by frequent connection/disconnection
- Better physical contact since ceramic materials have a lower Young's modulus than steel
- Ceramic material does not give off particles that may contaminate the parts of the bushing.

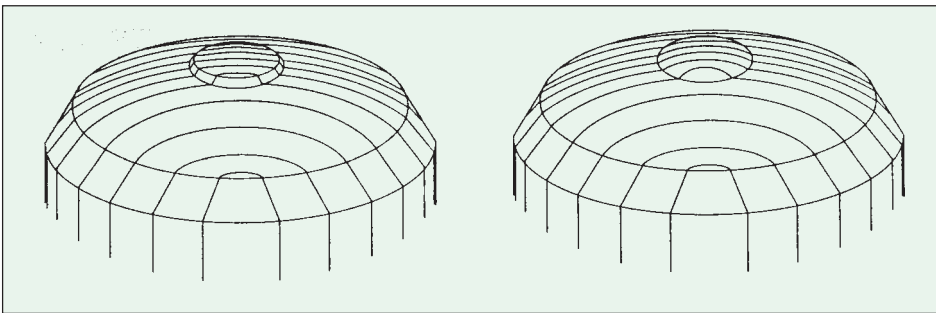

Fig. 8-29 The PC connector's ferrule is ground with a spherical curvature. The ferrule shown to the left has been ground according to the super PC method, and the ferrule to the right according to the ultra PC method.

The FC/PC connector is used primarily in telephone exchange optical distribution frames, repeaters, and along the line, for the connection of active elements or in high bit rate transmission (laser and low reflection required).

When the FC/PC connector's ferrules are to be ground hemispherical, they must be mounted by qualified personnel and ground in special machines. The connectors are mounted on 1- or 2-fiber cables (pigtailed) which are then spliced (either mechanically or by fusion) to the optical cable's fibers as a termination of line cables. Short lengths of 1- or 2-fiber optical cable - called patch cords - can be connected at both ends. These patch cords are used for connecting and disconnecting transmission equipment or measurement equipment. Both the FC and FC/PC connectors are screw-connected.

## SC connector

The SC connector, a new standard connector, was designed by Japan's NTT. The connector housing has a rectangular plastic casing with snap-in closure. The ferrule is spring-suspended and is pure ceramic (zirconium). The diameter of the

ferrule is the same as that of the FC or FC/PC connector. It has basically the same optical characteristics as the PC connector but, because of its rectangular shape, up to 8 times the packing density. All parts that do not affect the connector's optical performance are made of plastic. Its areas of application are the same as those of the previously described connectors.

A variant of the SC-connector is polished with an angle of 8 degrees. This gives the connector an extremely low value for return loss. The lower the value the less is the light that will be reflected back to the transmitting laser. Lasers developed for analog transmission (e.g. cable-TV system) are more sensitive regarding reflected light as it will distort the lasers transmitting performance.



Fig. 8-30 SC connector for standard applications.



Fig. 8-31 SC connector for analog transmissions, the ferrule is polished with 8 degree angle. These connectors are generally in green.

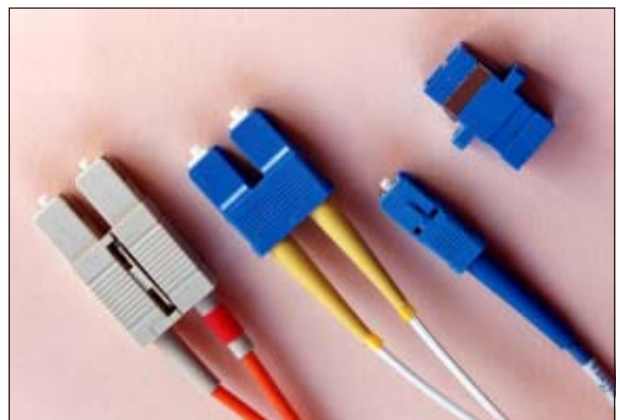

Fig. 8-32 The SC connector has high packing density thanks to its rectangular shape and snap-in closure.

### ST connector

ST connectors are manufactured for both single-mode and multimode fiber. The ST connector was developed with ease of handling as the prime consideration and has therefore a bayonet coupling to facilitate connection/disconnection. It resembles a BNC connector for coaxial cables. The ferrule is either metal/ceramic or completely ceramic.



Fig. 8-33 The ST connector with bayonet coupling and pure ceramic ferrule.

### FDDI connector

The first interface developed specifically for fiber optic data transmission was called the Fiber Distributed Data Interface (FDDI). As the name suggests, it was developed primarily for high-speed data networks that required long transmission distances (up to 2 km between nodes). The FDDI has a basic design of a double fiber ring, which means that a connector for an FDDI network must be in tandem format (ring in, ring out).



Fig. 8-34 Connector for FDDI network. The connector contains termination for fiber in and fiber out.

### Conical ferrule

A mechanical splice which is more complicated (in terms of manufacture) has conical ferrules. The end of the ferrules that are to meet are ground to a conical shape to facilitate centering (see Figure 8-35). The bushing into which they are pushed is biconically drilled. The performance of the splice is entirely dependent on the grinding of the conical end of the ferrules. Splices with this type of ferrule must be fitted in the factory. An average splice loss of 0.3 dB/connector is common.

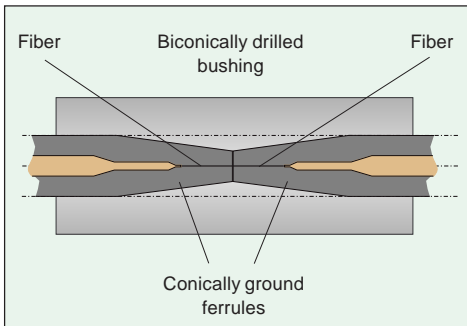

Fig. 8-35 Schematic diagram of a biconical splice.



Fig. 8-36 Biconical connector

### Expanded beam

For splices that will be exposed to dust, dirt and moisture, a more expensive method is used. The light from the transmitting fiber is expanded through a lens (see Figure 8-37) to produce a parallel beam of light rays which has a large diameter (compared to that of the fiber). After the splice, the rays

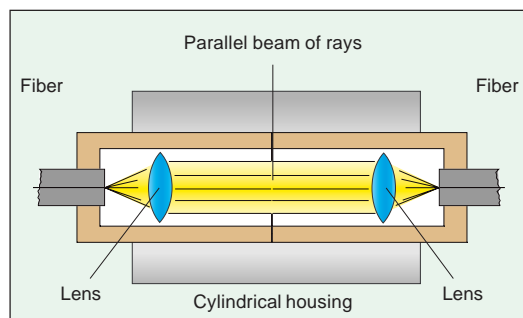

Fig. 8-37 Expanded beam splice. Usually, several fibers are terminated in a single splice.



are reconcentrated by a lens into the receiving fiber. This method is used mainly for splicing military field cable. The advantage of the method is that the mating end surfaces are not as exposed to pollutants as they are in other types of mechanical splice.

### Expanded beam connector or a connector for military field use

A special type of connector has been developed for use in particularly demanding environments and/or where stringent demands are placed on functionality. The fiber is protected by a lens at the end of the connector. The lens expands the beam from the fiber; the beam then passes through the connector to the other end, where an identical lens converges the light back into the receiving fiber end. Because the light beam is expanded, it is less sensitive to minor pollutants.



The expanded beam connector comes in different versions, for one to four fibers. It is used primarily in military applications.

Fig. 8-38 Military field connector utilizing the expanded beam concept.

### Connectors for fiber ribbon

Connectors for fiber ribbon do not have a cylindrical construction, for obvious reasons. A fiber ribbon consists of 2, 4, 8, 12 or more parallel, primary-coated fibers fixed together in a ribbon. The splice must therefore have a number of 125  $\mu\text{m}$  holes casted in a line. The distance between the holes in the connector must be close to the distance between the fibers in the ribbon, to avoid bending of the fibers. Figure 8-39 shows the basic design of a connector for fiber ribbon.

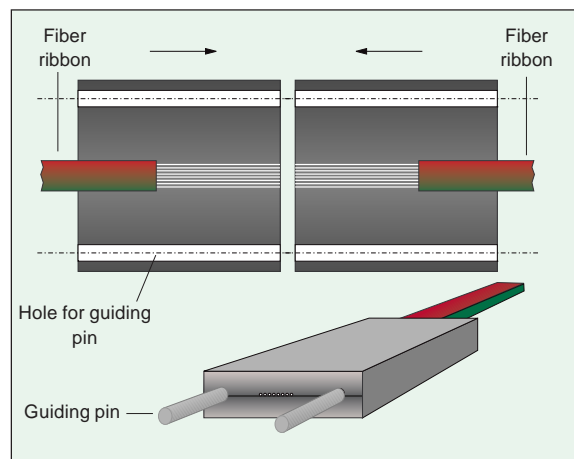

Fig. 8-39 Schematic diagram of a splice for a fiber ribbon

### MT connector

The MT connector is used for connecting cables of 2-, 4-, 8- or 12-fiber ribbons. The MT connector is exceptionally small; it measures only  $3 \times 7 \times 10$  mm. The connector has 2, 4, 8 or 12 holes casted side by side. To align the fibers, there are two metal rods which serve as guiding pins. The connecting surfaces are ground parallel and the connector is held together with a spring. The loss through the connector should be  $< 1$  dB.

The price of a MT-connector is slightly higher than the price for one single FC/PC or SC connector. In the future Access Networks or Fiber To The Home networks where cost will play an important role the possibility of connecting up to 12 fibers for the cost of previously connecting one fiber, will significantly reduce the total cost.



Fig. 8-40 Light coming out of a 12-fiber MT connector



Fig. 8-41 MT-connector for 4-, 8- and 12 fiber ribbon, note the guiding pin in middle connector.

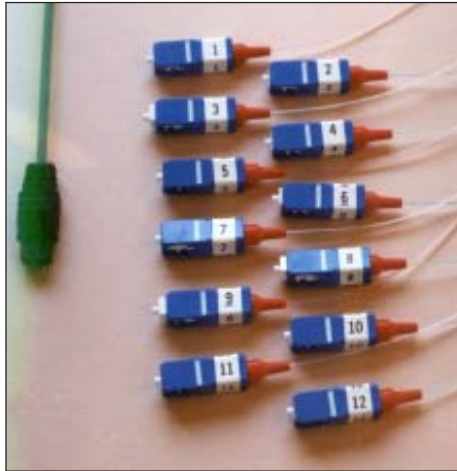

Fig. 8-42 Comparison between the 12-fiber MT-connector representing the ribbon technology and twelve SC-connectors representing the single fiber technology

## Summary

Optical fibers can be joined by either permanent or semipermanent splicing. The best splice is obtained by melting the fibers together using a fusion splicer. This method of splicing is inexpensive if a large number of splices are to be made. For smaller installations with less stringent demands on quality, mechanical splicing is the cheapest alternative.

A wide variety of connectors are available. For LANs and low-speed optical networks, connectors may be prepared, ground and polished on site, using special equipment, for each individual installation. Factory-ground connectors are always used for the termination of lines in telephone exchanges in large telecom networks, where performance and dependability are of paramount importance. Connectors are available for both single-mode and multimode fiber. In recent times, special connectors - e.g., FDDI - have been developed to meet network-specific requirements.

## Chapter 9

# The fiber optic link and system dimensioning

---

## Introduction

Most of the components that form part of a fiber optic link have been dealt with in detail in the preceding chapters: optical fibre cable, laser diodes and LEDs, optical detectors and the various types of splices and connectors. This chapter describes how these components together form a fiber optic system. We will look first at different types of network topology and then make some calculations for the dimensioning of a fiber optic link.

## Transmission media

One of the most important decisions to be made in the planning of a new installation, or the updating/expansion of an information network, is the choice of transmission media. Currently, there are four alternatives:

- copper
- optical fiber
- microwave (earth-bound)
- microwave (via satellite)

Decisions will most probably be based on the following factors:

- price: when a number of alternatives offer the same technical performance, the alternative with the best price/performance ratio should be chosen
- future technical potentialities: a new medium such as optical fiber offers new possibilities compared to an older medium

The advantages of an optical fiber based system compared to a copper based system are:

- extremely low losses
- broad bandwidth (almost unlimited for single-mode fiber)
- transmission is not affected by external interference, such as EMI and EMP
- an optical fiber based system does not generate interference
- an optical fiber based system is very difficult to tap
- future-proof capacity

On the basis of these advantages listed above, optical information networks are currently being built not only for long-distance communication, but also for:

- public local networks, access networks
- metropolitan networks
- large and small data communication networks
- cable TV networks
- security networks (bank and military networks)
- networks in severely disturbed environments
- alarm networks (optical sensors, etc).

## Network topology

An information network links two or more physical units (AXE exchanges, radio base stations, host computers, terminals, etc). There are three categories of transmission:

- simplex (transmission in one direction only)
- half-duplex (transmission in both directions, although not simultaneously)
- full-duplex (simultaneous transmission in both directions)

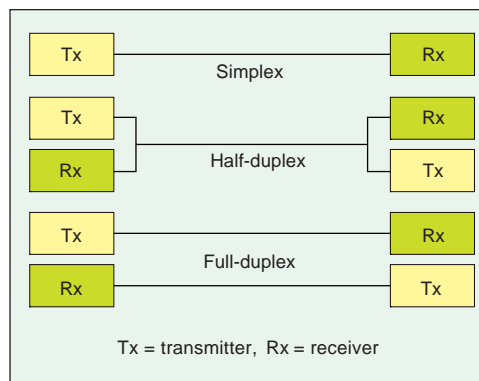

Fig. 9-1 Three different transmission methods: simplex, half-duplex and full-duplex.

The physical construction of a network is based on different principles:

- point-to-point
- star (single or multiple)
- tree (or snowflake)
- ring (single or double)
- bus

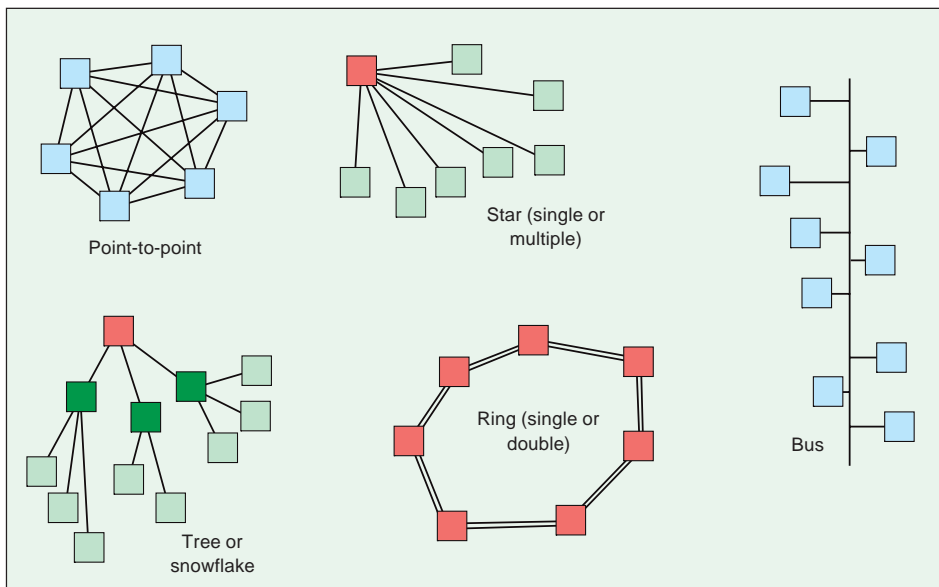

Fig. 9-2 Different network topologies.

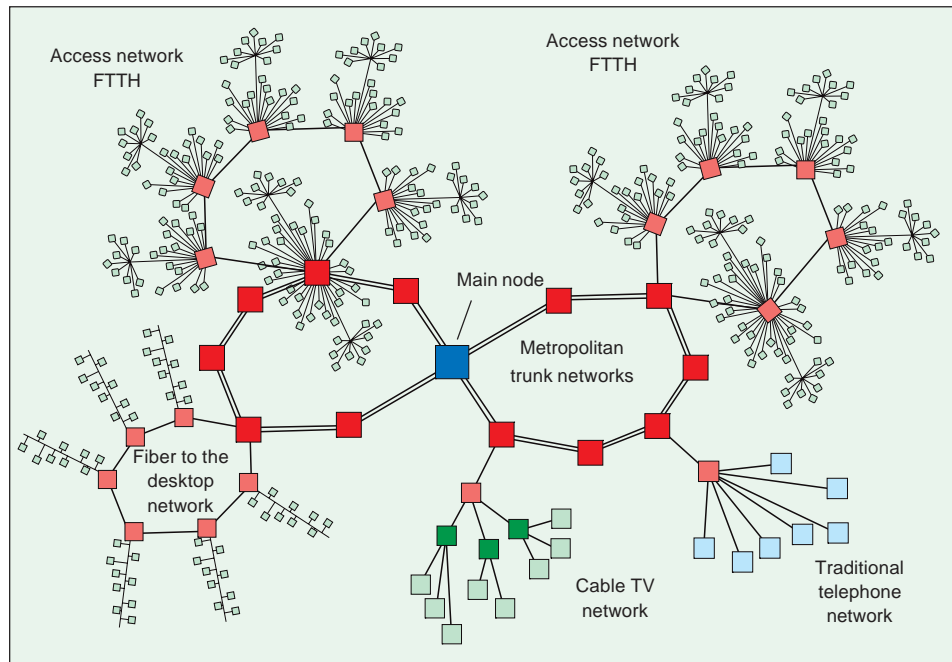

Fig. 9-3 Fiber optic infocom networks tends to be a mixture of different topologies. The above figure illustrates only a few samples of different networks.

## Requirements specifications for optical networks

Certain basic conditions must be taken into account in the planning of an optical network: a prescribed transmission capacity (bits per second), the transmission distance (km), and the required expansion capabilities. Normally, the applications used in a network also have a maximum permitted BER.

To fulfil these basic conditions, other network parameters are evaluated:

- choice of fiber (multimode or single-mode, step-index or graded-index fiber)
- the system's operating wavelength (850, 1310 or 1550 nm)
- type of transmitter (laser diode or LED)
- transmitter output power (into the fiber)
- type of receiver (photodiode or avalanche photodiode)
- transmission code
- BER
- type of interface (Token Ring®, Ethernet®, FDDI, etc)
- number of splices
- number of connectors
- security aspects
- environment protection aspects
- mechanical aspects.

For obvious reasons, a great deal of effort must be put into careful planning before any work can begin. One of the most uncertain factors is how future-proof the system will be, as regards physical expansion with more exchanges and in terms of requirements for increased transmission capacity. Can a fiber optic LAN

planned for 10 Mbit/s be upgraded to an FDDI for 100 Mbit/s? Will expensive investment in connectors, cable and network planning pay off if, in a couple of years, the time comes to upgrade the network? Those and many other questions must be dealt with in detail before the construction of a fiber optic network is begun. However, there are some simple, logical and rational rules to follow. The remainder of this chapter is devoted to some of these rules.

## Planning a fiber optic system

Planning an electric network involves taking into account many different factors between the transmitter and the receiver: resistance, resistance unbalance, capacitance, capacitance unbalance, impedance, crosstalk, electrical interference, etc. In the planning of a fiber optic network, all of these factors can be eliminated. In a fiber optic network, normally only the optical power budget, attenuation, bandwidth, and dispersion need to be calculated.

These factors determine whether or not a fiber optic system will function for a certain network topology, i.e., from the transmitter to the detector (receiver).

### Transmitter

As mentioned in a previous chapter, the average optical power that can be fed into a fiber is dependent on the type of transmitter, and on the bit rate. Figure 9-4 is a graph showing the bit rates for both a laser diode and an LED as transmitters. The graph shows that, with a laser diode, power levels of a couple of mW can be obtained; and with an LED, 100 - 200  $\mu$ W is usual. Note that both types give lower power as the bit rate increases. Generally, the input power to the fiber is 10–15 dB lower from an LED than that obtained from a laser diode. This is an important factor if noise at the receiving end's detector limits system capacity. The input power in a fiber is most often given in dBm.

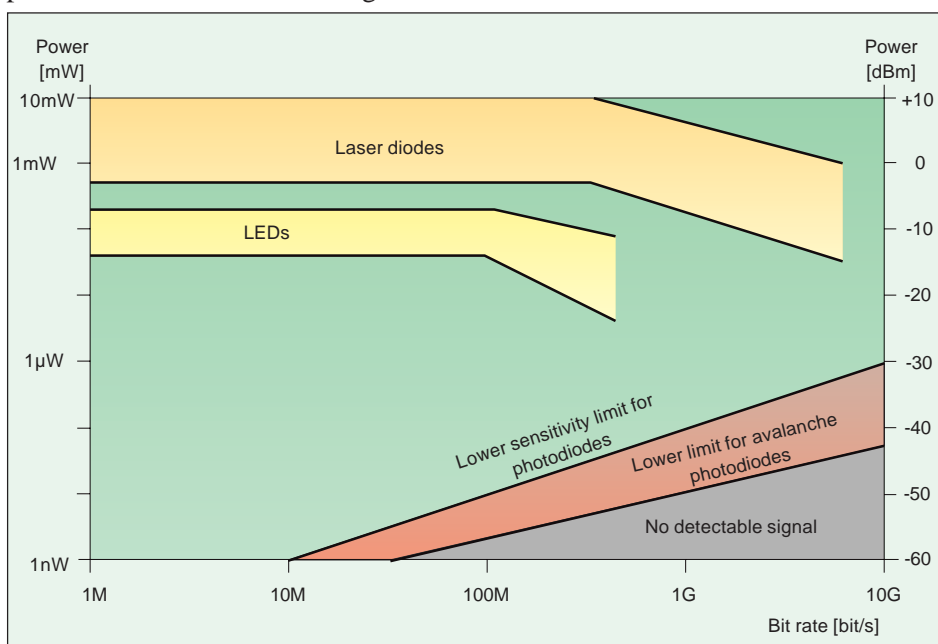

Fig. 9-4 Approximate limits for transmitters and receivers in fiber optic systems.

## Receiver

The sensitivity of a fiber optic receiver is determined by the combination of electric components that constitute the receiving end. The lowest detectable optical input power for a certain BER was dealt with in the chapter entitled “Optical detectors”. A BER of  $10^{-9}$  is used as the normal value. Normally, the lowest detectable input power for a photodiode is given in dBm related to a BER of  $10^{-9}$ .

## System dimensioning: Power budget

Calculating the power budget in an optical fiber based system is a simple means of analyzing and describing the losses in a network. The power budget provides the possibility of numerically establishing whether or not a network in the planned system will allow communication. The power budget is the input power into the fiber reduced by the receiver’s sensitivity. If the combined losses in the network are less than this value, sufficient light will reach the receiver to permit detection. Losses in a network are caused by:

- the fiber’s attenuation [dB/km]
- coupling of light from the transmitter to the fiber [dB]
- transition from one fiber diameter to another [dB]
- transition from one NA to a different NA [dB]
- connector losses [dB]
- splice losses [dB]
- branching [dB]
- coupling of light from the fiber to the receiver [dB]

All fiber optic systems must also have a power budget margin. The following examples - one simple and the second one more complex - will help you understand how a power budget is calculated:

### Power budget calculation - Example 1 (simple case)

A fiber optic link consists of the following:

- a transmitter with a power output coupled into the fiber  $P_t = 125 \mu\text{W}$
- a receiver with sensitivity  $P_r = -33 \text{ dBm}$
- fiber, 3.5 km long, with an attenuation  $A_f = 3.2 \text{ dB/km}$
- one splice with a loss  $A_s = 0.25 \text{ dB}$
- four connectors, each with a connector loss  $A_c = 1 \text{ dB}$
- a required power margin of  $P_m = 5 \text{ dB}$ .
- transmitter output power  $P_t = 125 \mu\text{W}$

$$\text{Power budget} \quad P_t - P_r = -9.03 - (-33) = 23.97 \text{ dB}$$

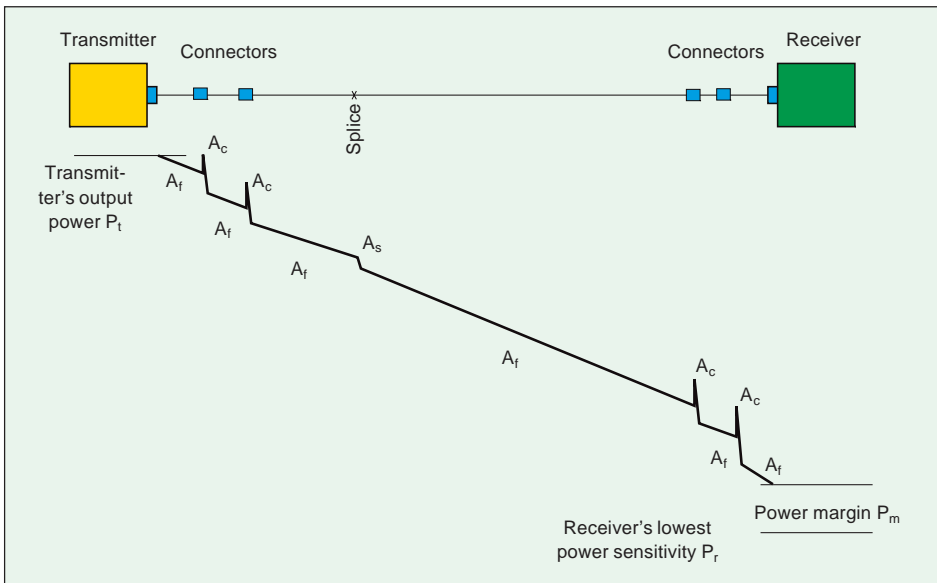

Fig. 9-5 Example 1: The constituent components and the OTDR curve, which shows the attenuation in the fiber optic link from transmitter to receiver.

Fiber attenuation	$A_f = 3.5 \times 3.2 = 11.2 \text{ dB}$
Connector attenuation	$A_c = 4 \times 1 = 4 \text{ dB}$
Splice attenuation	$A_s = 1 \times 0.25 = 0.25 \text{ dB}$
Power margin	$P_m = 5 \text{ dB}$

$$P_t - P_r > A_f + A_c + A_s + P_m$$

$$23.97 > 11.2 + 4 + 0.25 + 5$$

$$23.97 > 20.45;$$

The system has a margin for further losses.

**Conclusion:** The installation will function with respect to its optical power.

### Example 2 (complex case)

In this example, the power budget is calculated for a fiber optic link in a long-distance network. The network consists of both indoor and outdoor single-mode fiber cable. In total, eight cable lengths of 6 km each have been used. Some values for the cable in sections 3 and 7 differ from those for the rest of the sections.

The following is known:

- The optical transmitter has an output power of  $250 \mu\text{W}$ , an  $\text{NA} = 0.14$  and a diameter of  $14 \mu\text{m}$
- The transmitter is connected to a short patch cord with a core diameter of  $11 \mu\text{m}$ , an  $\text{NA} = 0.12$  and a connector loss of  $0.5 \text{ dB}$
- The patch cord is connected directly via an ODF box to an outdoor cable
- The outdoor cable for sections 1, 2, 4, 5, 6 and 8 has an attenuation of  $0.22 \text{ dB/km}$ , a core diameter of  $9.5 \mu\text{m}$  and an  $\text{NA} = 0.11$
- The outdoor cable for sections 3 and 7 has an attenuation of  $0.35 \text{ dB/km}$ , a core radius of  $10.5 \mu\text{m}$  and an  $\text{NA} = 0.12$



- All splices are fusion splices with a loss of less than 0.15 dB
- The coupling to the receiver is identical to the coupling at the transmitting end.
- The receiver has a sensitivity of 200 nW, a diameter of 25 μm and an NA = 0.4.

How large a power margin can be expected? The differences between NAs and core diameters assumed in the example above are quite common in real installations.

Figure 9-6 shows a simple sketch of all the constituent components for Example 2 and marks each point where calculation is required. The letters refer to the calculations given below.

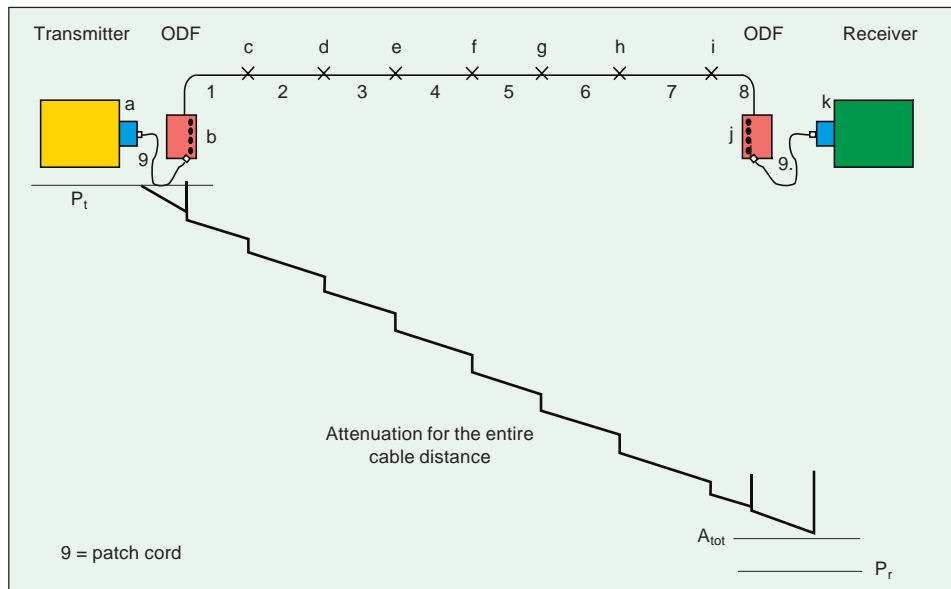

Fig. 9-6 Example 2: Each point where calculation is required is marked with a lower case letter.

### Calculations

- **Coupling loss at the transmitter (a)**

At the transmitter, losses will occur due to mismatch between NAs and between fiber core diameters, and at the connector (0.5 dB/each).

$$\text{Loss}_{NA} = -1.4 \text{ dB}$$

$$\text{Loss}_{\varnothing} = -2.1 \text{ dB}$$

$$\text{Connector loss} = -0.5 \text{ dB}$$

$$\text{Transmitter attenuation (A}_t\text{)} = \underline{4.0 \text{ dB}}$$

- **ODF box (b) at transmitting end**

Here, too, there is mismatch between NAs and between fiber core diameters, and connector loss.

$$\text{Loss}_{NA} = -0.8 \text{ dB}$$

$$\text{Loss}_{\varnothing} = -1.3 \text{ dB}$$

$$\text{Connector loss} = -1 \text{ dB}$$

$$\text{ODF box attenuation (A}_{ODF}\text{)} = \underline{3.1 \text{ dB}}$$

- **Fiber loss for the entire distance**

Six sections of fiber with a loss of 0.22 dB/km  
 $6 \times 6 \times 0.22 = -7.9 \text{ dB}$

Two sections of fiber with a loss of 0.35 dB/km  
 $2 \times 6 \times 0.35 = -4.2 \text{ dB}$

Fiber attenuation ( $A_f$ ) 12.1 dB

- **Power loss in fusion splices**

The entire cable length has seven fusion splices.  
 $7 \times 0.15 = -1.1 \text{ dB}$

Combined splice loss ( $A_s$ ) 1.1 dB

At c, f and g, there are no other losses.

- **Loss caused by the splicing of cable sections 3 and 7**

The splicing of cable sections 3 and 7 results in power loss, due to mismatch between NAs and fiber core diameters, only when the light leaves cable section 3 and 7 (at points e and i, respectively). At points d and h, power is lost only through splice loss as calculated above.

$\text{Loss}_{\text{NA}} = -0.8 \text{ dB}$

$\text{Loss}_{\emptyset} = -0.9 \text{ dB}$

Attenuation due to splicing of sections 3 and 7 ( $A_{df}$ ) 3.4 dB

- **Power loss ODF box at the receiving end (j)**

At the ODF box at the receiving end, power loss occurs only in the connector.

Attenuation at the ODF box, receiving end ( $A_{\text{ODF}}$ ) 1 dB

- **Power loss at the receiver (k)**

Because the receiver's NA and diameter exceed those of the connecting fiber, power is lost only in the connector.

Attenuation when the light is coupled into the receiver ( $A_r$ ) 0.5 dB

### Power budget

When all power loss (attenuation) values have been added together, the total power budget can be calculated.

$$P_t - P_r = (A_t) + (A_{\text{ODF}}) + (A_f) + (A_s) + (A_{df}) + (A_{\text{ODF}}) + (A_r) + (P_m)$$

Transmitter output power 250  $\mu\text{W}$  ( $P_t$ ) = -6 dB

Receiver sensitivity 200 nW ( $P_r$ ) = -37 dB

**Power budget ( $P_t - P_r$ ) = 31 dB**

#### Losses

Coupling loss, transmitting end ( $A_t$ ) 4.0 dB

ODF box, transmitting end ( $A_{\text{ODF}}$ ) 3.1 dB

Attenuation in the fiber ( $A_f$ )	12.1 dB
Loss in fusion splices ( $A_s$ )	1.1 dB
Splicing of sections 3 and 7 ( $A_{df}$ )	3.4 dB
ODF box, receiving end ( $A_{ODF}$ )	1.0 dB
Coupling loss, receiving end ( $A_r$ )	0.5 dB
<b>Total attenuation, entire link (<math>A_{tot}</math>)</b>	<b>25.2 dB</b>
<b>Power budget (<math>P_t - P_r</math>)</b>	<b>31.0 dB</b>
<b>Power margin (<math>P_m</math>)</b>	<b>5.8 dB</b>

As can be seen from the two examples, power budget calculation is relatively simple and straightforward. Power budget calculation only ensures that, in spite of attenuation, sufficient power will reach the receiving end for detection to occur. However, the bandwidth is another limiting factor for the performance of a link, i.e., for the transmission distance and signal characteristics.

### Summary of system dimensioning: Attenuation

A systematic method of dimensioning an optical fiber link in terms of attenuation may be summarized as follows:

- Define the optical interface between the transmitter and receiver.
- Determine the transmitter's optical power output level in its optical interface by measurement or from data sheets [ $P_t$ ].
- Determine the optical sensitivity threshold in the receiver's optical interface; i.e., the value required to achieve the desired signal characteristics in the receiver's electrical interface.
- Calculate the total transmission loss between the two optical interfaces (coupling into the fiber from the transmitter; through cable, splices and connectors; and coupling into the receiver from the fiber) [ $A_{tot}$ ].
- Calculate the system's power margin [ $P_m$ ];  $P_m = P_t - P_r - A_{tot}$

The system's power margin should cover:

- Degradation of the transmitter/receiver (should be replaced at a degradation of 3 dB)
- Temperature variations
- Possible repairs to the cable
- Connector wear.

## System dimensioning: Bandwidth

To ensure a minimum level of distortion of the signal (analog or digital) transmitted on a link, the bandwidth of the link must be sufficiently broad. A rule of thumb in digital signaling is that the minimum transmitted pulse duration should be 1.5 times greater than the link's total rise time.

Dispersion, rise time and bandwidth are related to each other according to constants, whose values vary with the shape of the optical pulse. Calculations in which Gaussian pulses are used give the most realistic results (see Figure 9-7).

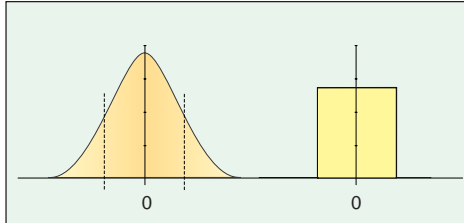

Fig. 9-7 Gaussian pulse compared to a digital pulse. In high-speed systems, the Gaussian pulse is closer to reality.

## Chromatic dispersion

Chromatic dispersion is in fact a combination of material dispersion and waveguide dispersion but in general usage, the term chromatic dispersion means the sum of both material dispersion and waveguide dispersion. Chromatic dispersion is waveguide and wavelength dependant and is negligible for systems with low (<100 MHz) transmission speed and for short transmission distances (< 5 km). Chromatic dispersion is also negligible in broadband links which use LEDs as the transmitting light source. Modal dispersion can be a limiting factor for links using multimode, step-index fiber, but is rarely so for links using graded-index fiber. This type of dispersion varies linearly with the length up to the coupling length ( $L_c < 0.5 - 1$  km) and then as  $\sqrt{L}$ .

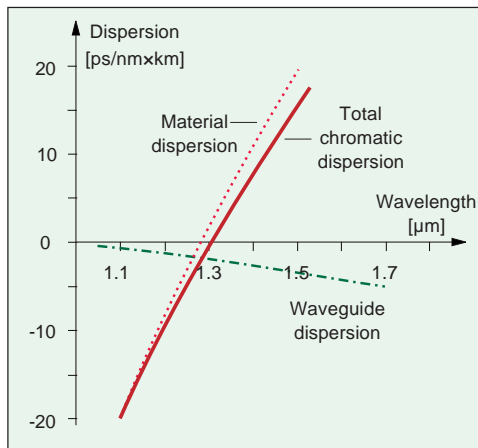

Fig. 9-8 The chromatic dispersion is the sum of material- and waveguide dispersion.

## Pulse broadening due to chromatic dispersion $\sigma_{\text{chrome}}$

Pulse broadening due to chromatic dispersion is calculated according to the formula given below. The constant  $D(\lambda)$  is given in the data sheets for each fiber.

$$\sigma_{\text{chrome}} = D(\lambda) \cdot \Delta\lambda \cdot L [\text{ps}]$$

Formula 9-1.

where  $D(\lambda)$  is the chromatic (material and waveguide) dispersion

- $D(\lambda) \approx 100 + 0.4 (850 - \lambda)$  [ps/nm×km] for  $800 < \lambda < 900$  nm
- $D(\lambda) \leq 3,5$  ps/nm×km for  $1285 < \lambda < 1330$  nm
- $D(\lambda) \leq 17$  ps/nm×km for  $1525 < \lambda < 1575$  nm
- $\Delta\lambda$  = transmitter's spectral bandwidth
- $L$  = length of fiber link (km)

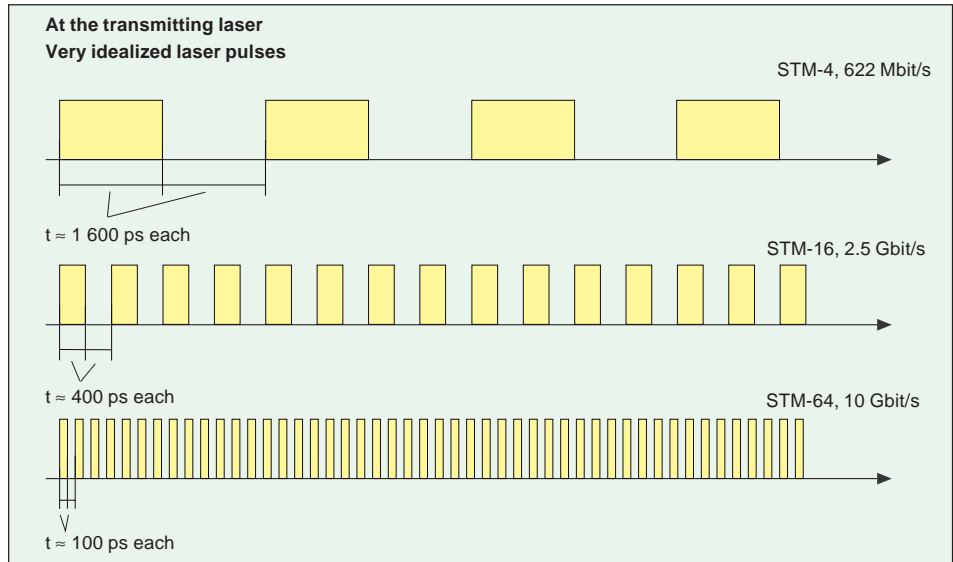

Fig. 9-9 Illustration of light pulses representing a digital “1” and a digital “0” (no light). Timing refer to an idealized system.

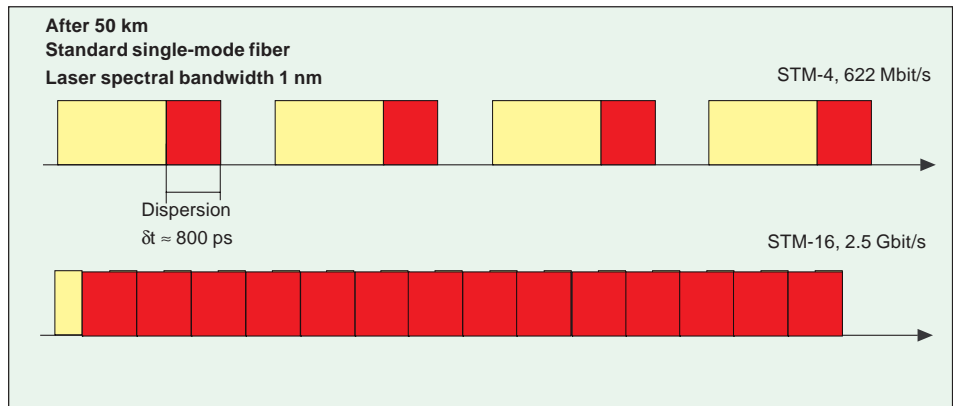

Fig. 9-10 Chromatic dispersion for a standard single-mode fiber after 50 km. The chromatic dispersion is 16 ps/nm×km. The spectral bandwidth of the transmitting laser is set to 1 nm. Both the STM-16 and the STM-64 system will fail.

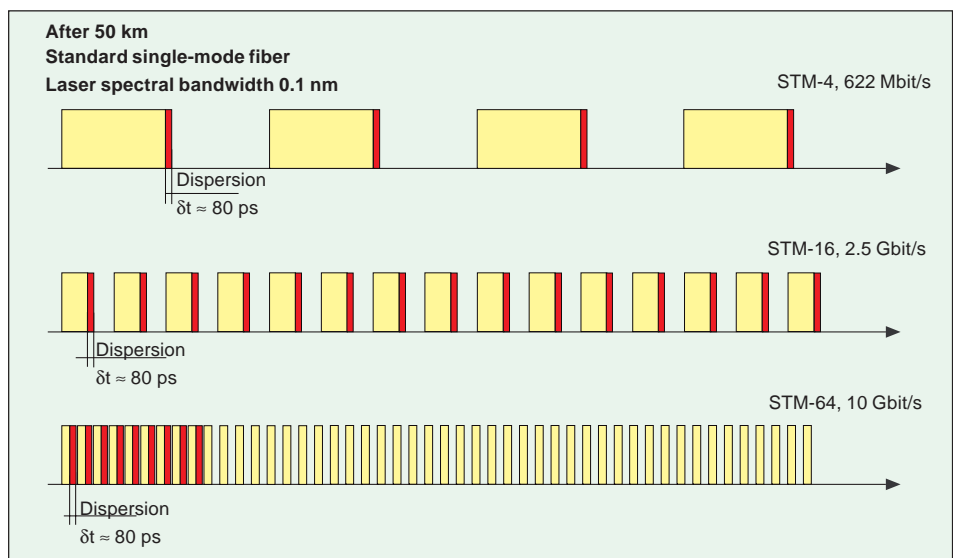

Fig. 9-11 Chromatic dispersion for a standard single-mode fiber after 50 km. The chromatic dispersion is 16 ps/nm×km. The spectral bandwidth of the transmitting laser is set to 0.1 nm. Only the STM-64 will fail.

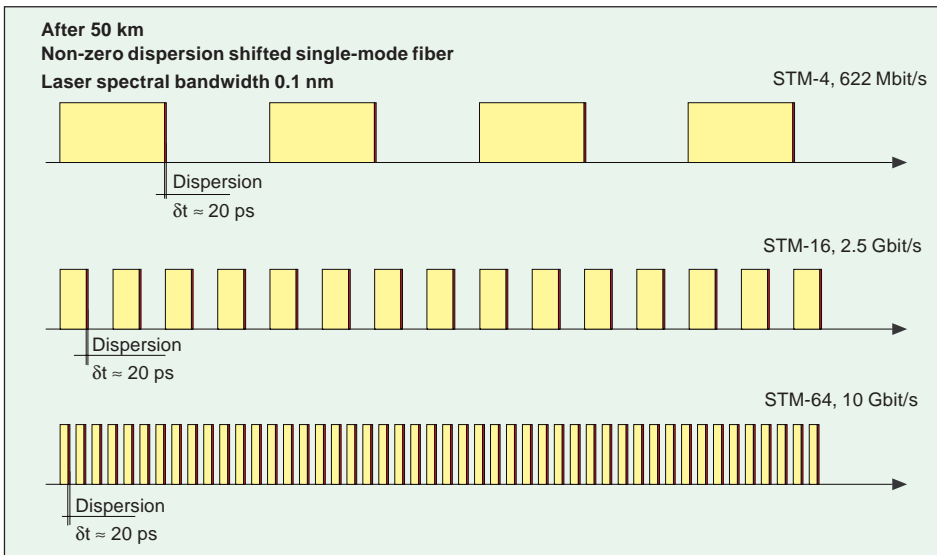

Fig. 9-12 Chromatic dispersion for a non-zero dispersion shifted single-mode fiber after 50 km. The chromatic dispersion is  $4 \text{ ps/nm} \times \text{km}$ . The spectral bandwidth of the transmitting laser is set to  $0.1 \text{ nm}$ . All the three systems will function properly.

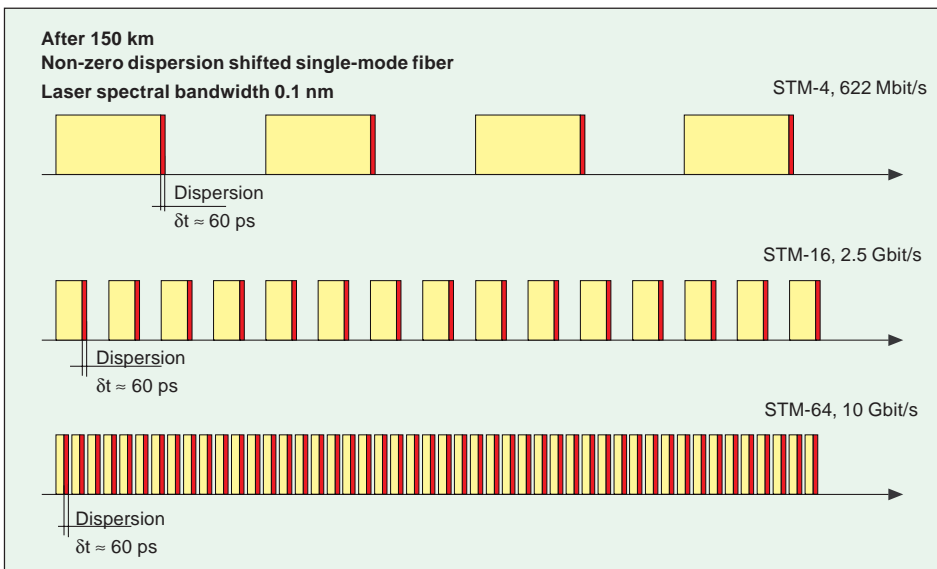

Fig. 9-12 Chromatic dispersion for a non-zero dispersion shifted single-mode fiber after 150 km. The chromatic dispersion is  $4 \text{ ps/nm} \times \text{km}$ . The spectral bandwidth of the transmitting laser is set to  $0.1 \text{ nm}$ . All the three systems will function properly.

The series of figures (Figure 9-9 – Figure 9-13) on the two previous pages illustrate what happens to an idealized light pulse when guided through different types of single-mode fibers at the 1550 nm wavelength. For 1310 nm the chromatic dispersion is close to zero thus making the chromatic dispersion less critical for long transmission spans at high bit rates. Illustrated is also the importance of using narrow spectral bandwidth lasers, especially for extreme long distance between repeaters. Not illustrated, but has to be taken into consideration for long distance communication is the complete power budget.

### Time delay ( $\delta T_{\text{modal}}$ ) and pulse broadening ( $\sigma_{\text{modal}}$ ) due to modal dispersion

Time delay and pulse broadening caused by modal dispersion (occurs only in multimode fibers) is due to different modes propagating in the fiber core. The greatest modal dispersion, which occurs in multimode, step-index fiber (as mentioned in the chapter entitled “Optical fiber and fiber optic parameters” can be reduced dramatically by increasing the refractive index closer to the center, i.e., a graded-index profile. For single-mode transmission, there is no modal dispersion. Time delay difference and pulse broadening due to modal dispersion can be calculated according to the following formula:

Time delay difference in a step-index multimode fiber

$$\delta T_{\text{step}} = \frac{L \cdot n_2^2}{c \cdot n_1} \left( \frac{n_2 - n_1}{n_2} \right) \approx \frac{L \cdot (NA)^2}{2 \cdot c \cdot n_2} \quad \text{when } \Delta = \frac{n_2 - n_1}{n_1} \ll 1 \quad \text{Formula 9-2}$$

and rms pulse broadening

$$\sigma_{\text{step}}^2 = \frac{1}{3} \left( \frac{\delta T_{\text{step}}}{2} \right)^2; \text{ hence substituting } \delta T_{\text{step}} \quad \text{Formula 9-3}$$

$$\sigma_{\text{step}} \cong \frac{L \cdot n_2 \cdot \Delta}{2 \sqrt{3} \cdot c} \cong \frac{L \cdot (NA)^2}{4 \sqrt{3} \cdot n_2 \cdot c} \quad \text{Formula 9-4}$$

Time delay difference in a graded index multimode fiber (parabolic)

$$\delta T_{\text{graded}} \cong \frac{L \cdot n_2 \cdot \Delta^2}{2 \cdot c} \cong \frac{(NA)^4}{8 \cdot n_2^3 \cdot c} \quad \text{Formula 9-5}$$

and the rms pulse broadening in a graded index multimode fiber

$$\sigma_{\text{graded}} = \frac{L \cdot n_2 \cdot \Delta^2}{20 \sqrt{3} \cdot c}; \text{ where } \Delta \approx \frac{n_2 - n_1}{n_1} \quad \text{Formula 9-6}$$

### Total pulse broadening due to dispersion in multimode fibers

The total (rms) pulse broadening due to chromatic (intramodal) dispersion and modal (intermodal) dispersion can be calculated according to the following formula:

$$\sigma_{\text{tot}} = \sqrt{\sigma_{\text{chrome}}^2 + \sigma_{\text{modal}}^2} \quad \text{Formula 9-7}$$

### Bandwidth in multimode fibers

As described in the chapter on optical detectors, the active components have a finite rise time in relation to the incoming signal: there is a certain delay between the incoming and outgoing signals. This results in the components having a certain usable frequency range — the bandwidth. In the same way, dispersion limits the fiber’s usable frequency range — the fiber’s bandwidth.

The formula below applies only to a Gaussian pulse shape. The bandwidth is calculated for a pulse duration that is 3 dB less than the maximum value.

$$\text{Optically, } B_{3\text{dB,optical}} = \frac{0.44}{\sigma_{\text{tot}}} \quad \sigma \text{ in (ns) gives B (GHz)} \quad \text{Formula 9-8}$$

$$B_{3\text{dB,optical}} = \sqrt{2} \cdot B_{3\text{dB,electrical}} \quad \text{Formula 9-9}$$

$$\text{Electrically, } B_{3\text{dB,electrical}} = \frac{0.33}{\sigma_{\text{tot}}} \quad \sigma \text{ in (ns) gives B (GHz)} \quad \text{Formula 9-10}$$

The optical bandwidth is as seen above not identical with the electrical bandwidth due to the fact that the optical power produces a received current. Therefore, one has to use two different expressions:

$^{10}\log(A)$  on the optical side

$^{20}\log(A)$  on the electrical side

For example, if the optical signal power has decreased to 50%, we will have  $^{10}\log(0.5) = -3$  [dB]. This means, of course, that also the electrical current has decreased with 50%, that is  $^{20}\log(0.5) = -6$  [dB]. Alternatively, if we calculate the electrical power values we again get  $^{10}\log(0.5^2) = -6$  [dB] on the electrical side as it should be. This effect causes a factor  $\sqrt{2}$  difference in 3 dB bandwidth between the optical and electrical side.

In technical specifications for multimode fibers the bandwidth is normally expressed in MHz×km. For a given length of fiber it therefore easy to calculate if the specified fiber bandwidth is sufficient for the application in question [Bandwidth required (MHz) × fiber length (km) ≤ Specified bandwidth (MHz × km)].

## Bandwidth in single-mode fibers

The situation in a single-mode fiber is somewhat more complicated and the calculations are not within the aim of this book. A rough approximation may be gained from the formula below:

$$\text{Bandwidth}_{(\text{single-mode})} \approx \frac{0.44}{\Delta\lambda \cdot D(\lambda) \cdot L} \quad \text{Formula 9-11}$$

where

$D(\lambda)$  = Chromatic dispersion of the fiber [ps / nm×km]

$\Delta\lambda$  = Spectral width of the light source [nm]

$L$  = Length of fiber [km]

Studying the terms above yields that a greater dispersion and a wider spectral width of the source the lower will the bandwidth be.

## Fiber rise time

In a singlemode fiber, it is the chromatic dispersion alone that sets the upper limit to the fiber bandwidth. For common standard fiber, the bandwidth exceeds



100 GHz×km for 1310 nm. For multimode fiber, modal dispersion sets the upper limit to the bandwidth and, thus, the rise time for the fiber.

The rise time is calculated according to the following formula:

$$t(\text{ns}) = \frac{0.35}{\text{bandwidth}(\text{GHz})} \quad \text{Formula 9-12}$$

The rise time is dependent on the length of the fiber, which means that it must be calculated for a given fiber section. If a multimode fiber is specified for 800 MHz×km and the fiber section is 4 km, the bandwidth will be only 200 MHz and the rise time  $t_f = 1.75$  ns.

The link's total rise time (T) is calculated as the square root of the sum of the squared rise times for the transmitter, receiver and fiber.

$$T = \sqrt{t_1^2 + t_2^2 + \dots + t_{n-1}^2 + t_n^2} \quad \text{Formula 9-13}$$

The transmitter's and receiver's rise times are obtained from data sheets or by measurements. The fiber's rise time is determined by two components: chromatic dispersion and modal dispersion.

### Rise time of the optical link (multimode system)

A systematic method of determining the bandwidth of an optical fiber link may be summarized as follows:

- Determine the transmitter rise/fall time from the data sheets or by measurement [ $t_t$ ].
- Determine the receiver rise/fall time from the data sheets or by measurement [ $t_r$ ].
- Calculate the rise/fall time of the optical fiber cable from the data on material dispersion and modal dispersion [ $t_f$ ].
- Calculate the total rise/fall time [T] of the link as follows:

$$T(10-90\%) = \sqrt{t_{\text{transmitter}}^2 + t_{\text{fiber}}^2 + t_{\text{receiver}}^2} \quad \text{Formula 9-14}$$

- Calculate the bandwidth of the link as follows:

$$B_{3\text{dB,electrical}}(\text{GHz}) = \frac{0.35}{T(\text{ns})} \quad \text{Formula 9-15}$$

For digital transmission, a rule of thumb says that  $T_{\text{pulse}} \geq 1.5 \times T$ . This gives a transmission speed in Gbit/s for data transmission in accordance with the NRZ method of:

$$\text{NRZ}_{\text{data speed}}(\text{Gbit/s}) = \frac{1}{T_{\text{pulse}}(\text{ns})} \leq \frac{0.67}{T(\text{ns})} \quad \text{Formula 9-16}$$

**Calculation example**

Consider a fiber optic network with a transmission speed of 100 MHz and a longest transmission distance of 6 km. The transmitter's and receiver's rise times are each 1 ns. There are two types of graded-index fiber available: one with a bandwidth of 400 MHz×km and the other with a bandwidth of 800 MHz×km. Can both be used?

The system requires a rise time of less than 3.5 ns.

The fiber with the 400 MHz×km bandwidth has a bandwidth of only 66.6 MHz for a 6 km long section, which results in a rise time of 5.25 ns! In other words, it is not possible to use this fiber.

The fiber with the 800 MHz×km bandwidth has a bandwidth of 133.3 MHz for a 6 km long section and a rise time of 2.63 ns. This means that the rise time lies under the value specified for the system. Taking into account the other components, a rise time for the system is calculated according to:

$$T(10-90\%) = \sqrt{t_{\text{transmitter}}^2 + t_{\text{fiber}}^2 + t_{\text{receiver}}^2} \quad \text{Formula 9-17}$$

$$T(10-90\%) = \sqrt{1^2 + 2.63^2 + 1^2} \approx \sqrt{8.91} \approx 2.98 \quad \text{Formula 9-18}$$

The system should function with the second fiber, even though the margin is small. A better result would be obtained with a faster transmitter and receiver.

## Summary

For an optical fiber link, power budget calculation is used to determine whether or not the total attenuation (loss of power) in connectors, in fiber and in the coupling into and out of the fiber exceeds the available power. There must always be a certain margin above the power budget.

A similar calculation is carried out for the rise time of all system components. The combined rise time must not exceed the value specified for the system.

## Chapter 10

# Optical fiber measuring instruments and testing in single-mode fiber networks

---

## Introduction

This chapter is somewhat different from the previous chapters, in that it primarily contains directions about measuring and testing optical fiber installations of single-mode fiber.

The business of optical fiber measuring instruments is flourishing: new instruments offering better performance and facilities are being developed all the time. This chapter on measuring instruments therefore deals with general principles only - not with any specific instrument.

Measuring principles and routines will undoubtedly change in the future, so this chapter only provides general advice and instructions. It deals primarily with measurement and testing in the installation of optical fiber cable networks, and with the final documentation of completed installations.

NOTE: Measurement requirements - including a specification of mandatory measurements - are always stated in the contract for the project in question and may vary from installation to installation. The contract or project description should therefore be checked for details of measurement and testing procedures.

## Optical fiber measuring instruments

Generally, three types of measuring instrument are used when optical fiber cable is installed:

- Optical Time Domain Reflectometer (OTDR)
- Stabilized light source (laser diode module)
- Optical power meter with optical sensor.

## Optical Time Domain Reflectometer (OTDR)

The OTDR is used for most measurements and is more or less the “universal” optical fiber measuring instrument. The OTDR is used for quality control of cable on drums and after laying, and for determining splice loss, verification of an installation, and fault tracing.

Modern OTDR instruments allow easy change of the laser diode module with a click of a switch, which facilitates measurements at different wavelengths.

The different fiber parameters should be verified at the same wavelength as that of the system to be connected to the installation. For single-mode fiber cable, 1550 nm is the most common wavelength, but fibers should also be tested at 1310 nm.

As a rule, the instruments have built-in printers that provide a hard copy of measurement results. An external video plotter can also be connected to an OTDR.

Today are, in general, three different types of OTDR instruments available in the market:

- Stationary, highly qualified instruments mainly intended for optical fiber and optical fiber cable manufacturer. They can perform automated measuring in the production lines and controlled by computer programs, thus creating protocols to be handed over with the manufactured product. The measuring precision exceeds the normal need for in the field use, eg. installation of fiber optic cables in distances less the 80–100 km.
- Portable light weight OTDR for network installation companies. These portable instruments contain not only the measuring instrument but also a complete computer that analyze the measured results, present the analyzed results in event tables, storage of measured results are available in the form of diskettes, hard disk or printed documents that can be used for final documentation of a fiber optic network. The different variants of portable OTDRs are in most cases sufficient for all measuring needs when installing fiber optic networks from long distance trunk networks to a local fiber to the home network.
- An alternative to a complete OTDR is an OTDR printed board assembly, which can be installed in most PCs. Measurements are carried out in the same manner as with an OTDR instrument, but the results are stored in the PC - for printout or storage on a diskette. These types of instruments are losing their importance in favour to the portable OTDR.

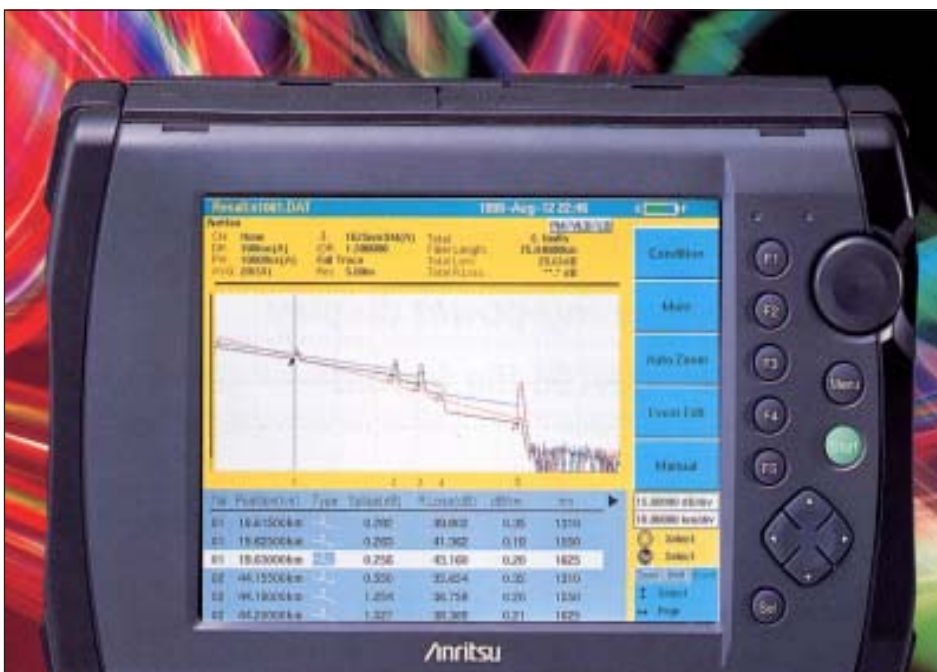

Fig. 10-1 Portable OTDR. Photo courtesy of Anritsu Inc.

## Usability

OTDRs may be used for different types of measurement:

- Distance measurement (fault tracing)
- Attenuation measurement in fibers, optical fiber links and splices
- Splice loss after fusion splicing
- Connector loss
- Detection of local attenuation variations (stepwise or gradual increases)
- Reflection at connectors or the end reflection pulse (end pulse).

## How the OTDR works

As its name suggests, the OTDR's function is based on the propagation of light in an optical fiber during a specific length of time. Figure 173 is a schematic illustration of an OTDR instrument.

In a pulse generator, short (e.g. 0.01 to 10  $\mu$ s) electric pulses with specific time intervals are generated. The electric pulses are transformed into light pulses in the laser diode. A light pulse passes a directional coupler before it is sent out to the fiber. Because the fiber is not completely transparent a certain amount of light will be returned into the instrument, due to Rayleigh scattering or reflections. The returned light is detected by an avalanche photodiode (APD). The signal from the APD is amplified by an amplifier and processed by a microprocessor. The optical signal is weak, and the process is therefore repeated several times to provide a basis for an average value.

The signal strength is represented by the vertical axis of a coordinate system, and time (often transformed into distance) is represented by the horizontal axis.

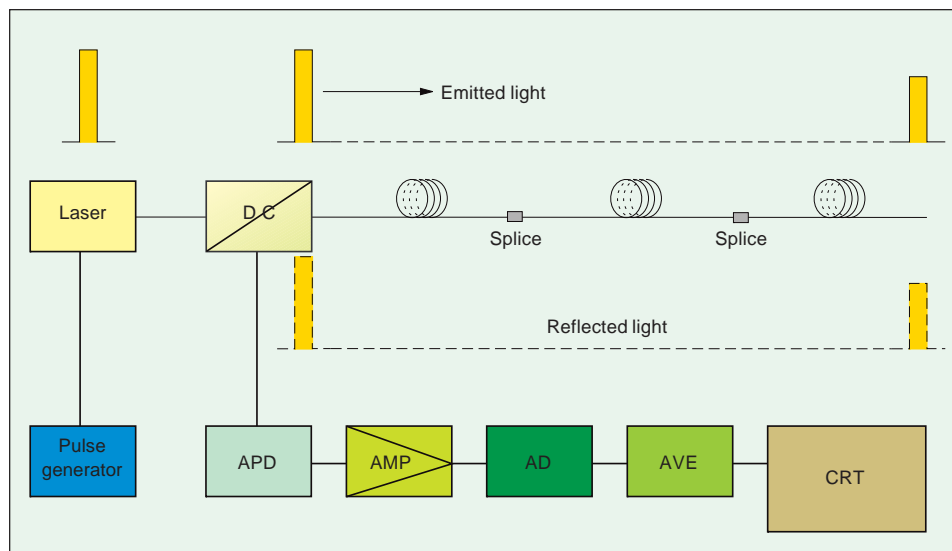

Fig. 10-2 Schematic illustration of the main parts of an OTDR.

The coordinate system is shown together with other useful information on a video screen. The optical signal from the fiber is shown as a curve sloping from left to right. Normally, the video screen image is printed out directly on a built-in printer or stored on a diskette or built-in hard disk. A printout is then saved together with the disk files for the final documentation of the installation. An idealized printout is shown with a simple analyze in the next page

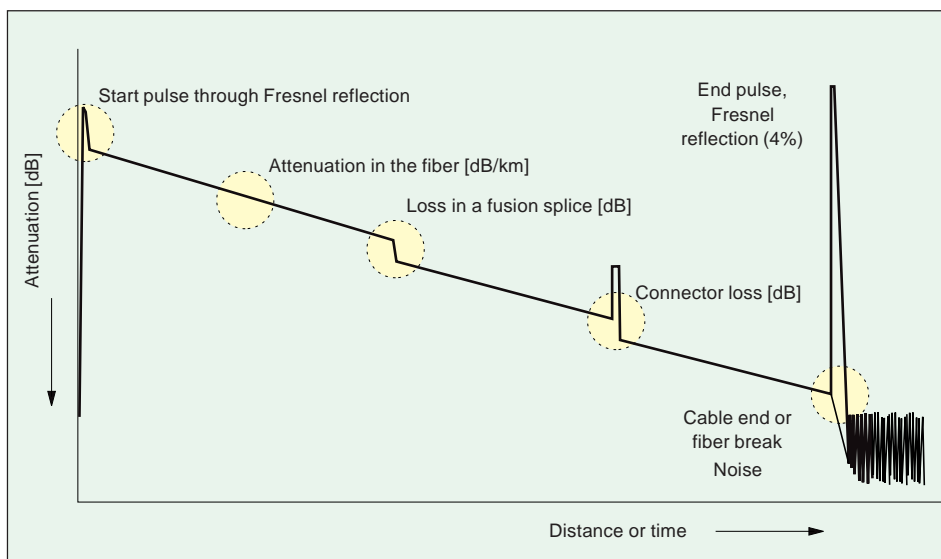

Fig. 10-3 Simplified graph from an OTDR.

### Different types of OTDR measurement

Only simple descriptions of the different types of measurement that can be carried out with an OTDR are given in the following. For more detailed information, refer to the instrument manufacturer’s manual.

#### Distance measurement

Using an OTDR, the length of an optical fiber can be determined with a high degree of accuracy. This is especially useful when determine the distance between splices and the length of the completed installation. It is also the only method to determine the distance to faults like a cut cable, broken fiber or an increase of attenuation in the fiber caused by preassure, water or what ever may be the cause of attenuation increase.

It is of importance to know the meaning of setting the correct IOR (index of refraction) in the OTDR. The wrong setting will give the wrong length of cable or the wrong distance to a fault. In a network situation the distance to measure is nearly always the length of the cable. The fiber is always longer then the cable as the fiber is stranded in the cable thus making a circumpherial loop around the cable core.

Note: Use a long cable with known length and measure it with the OTDR. Set the IOR so that the measured length corresponds with the known cable length. Make a note of the IOR and fix it to the OTDR instrument.

$$L = \frac{v \cdot t}{2} = \frac{c \cdot t}{2 \cdot n}$$

Formula 10-1

- v = velocity of light in the optical fiber [m/s]
- t = propagation time [s]
- L = length of the optical fiber [m]
- c = velocity of light in a vacuum [m/s]
- n = group refractive index of the core

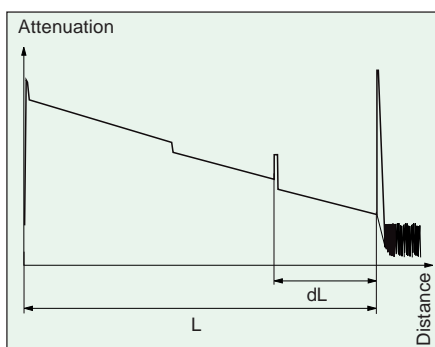

Fig. 10-4 OTDR curve and how it is used for distance measurement.

**Optical power loss - attenuation**

Because power is shown on the vertical axis, the power loss can be calculated by subtracting one power level from another.

Optical power loss  $A(\alpha)$

$$A(\alpha) = \frac{P_1 - P_2}{2} \quad \text{Formula 10-2}$$

Optical power loss per unit of length (dB/lu.)

$$A(\alpha) = \frac{P_1 - P_2}{2 \cdot L} \quad \text{Formula 10-3}$$

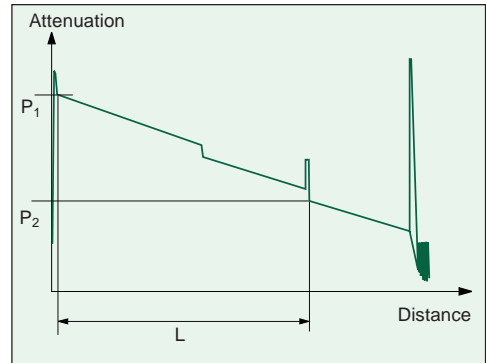

Fig. 10-5 OTDR curve and its use in attenuation measurement.

**Splice loss measurement**

When an OTDR is used for measurement, the graph obtained shows the attenuation in a cable section. If the section contains splices (either mechanical or fusion splices) these are normally shown as knees on the graph. The loss in each splice can be determined by measuring in these points - either according to the two-point method or the “many-point method”

**The two-point method**

Two measurement points on the graph: at  $(x_1, y_1)$  and at  $(x_1, y_2)$

The splice loss  $A(s)$  is calculated according to:

$$A(s) = y_1 - y_2 \quad \text{Formula 10-4}$$

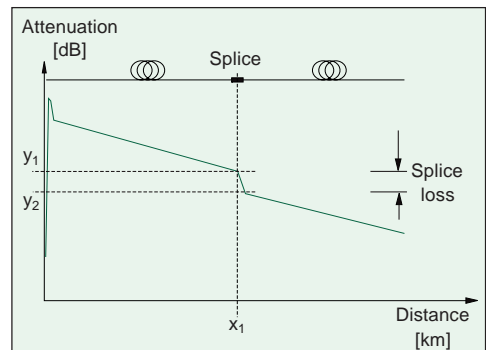

Fig. 10-6 Two-point method.

**The many-point method**

Measurements are made with a help of a number of points (four, five six or seven are common) on the graph in such a way that at least two of the points are before the splice and at least two beyond. A central point is positioned in front of and close to the splice. Here is described the method using five points.

A line  $y_1 = a_1x + b_1$  is drawn through the two points before the splice, and a second line  $y_2 = a_2x + b_2$  is drawn through the points beyond the splice.

The splice loss at  $x_s$  is thus:

$$A(x_s) = y_1 - y_2 = x_s (a_1 - a_2) + (b_1 - b_2) \quad \text{Formula 10-5}$$

The calculation shown on previous page is done by a microprocessor-based program, and the value of the equation is displayed on the video screen.

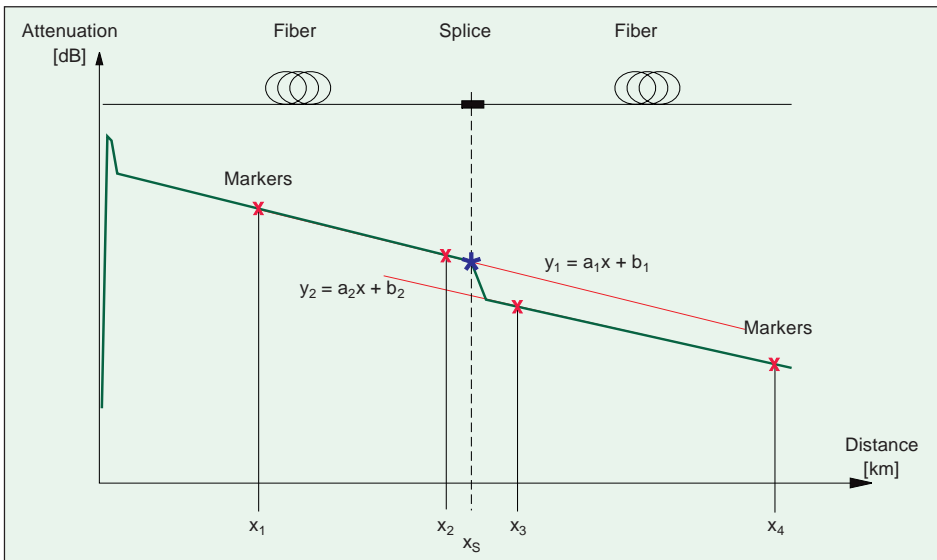

Fig. 10-7 Five-point method.

### Getting the splice loss value

It is important to remember that documented splice-loss is the sum of the measured splice-loss in both directions divided with two.

$$Splice\ loss = \frac{Splice\ loss_{A \rightarrow B} + Splice\ loss_{B \rightarrow A}}{2} \quad \text{Formula 10-5}$$

Example:

$$Splice\ loss = \frac{0.08\ dB_{A \rightarrow B} + (-0.04\ dB)_{B \rightarrow A}}{2} = 0.02\ dB$$

### Remarks

The OTDR instrument has a lot of settings that will effect the quality of the graph, thus effecting the quality of the measured result.

#### Dead zone

Every splice or connector cause a disturbance in the optical signal both transmitted and reflected. The disturbance will create a zone in the fiber after the splice or connector that is not possible to study. Typically a splice in an optical distribution frame (ODF) can not be measured as it is to close to the connector where the optical signal enters the ODF. The quality of the same splice can not be measured in the opposite direction either as the splice will be to close to the strong end pulse caused by the same connector.

If a fiber is spliced twice within a couple of meters the graph will show the splices as being a single splice with an accumulated splice loss

#### Pulse width

Setting a short pulse width (ns), makes it possible to study the installed fiber after just a few meters making the “dead zone” as short as possible, note the above. Unfortunately a short pulse width will create a more distorted signal the longer the distance. A long pulse width (μs) must be used for long distance measuring as it creates a better and more useful graph, on the other hand the dead zone increases.



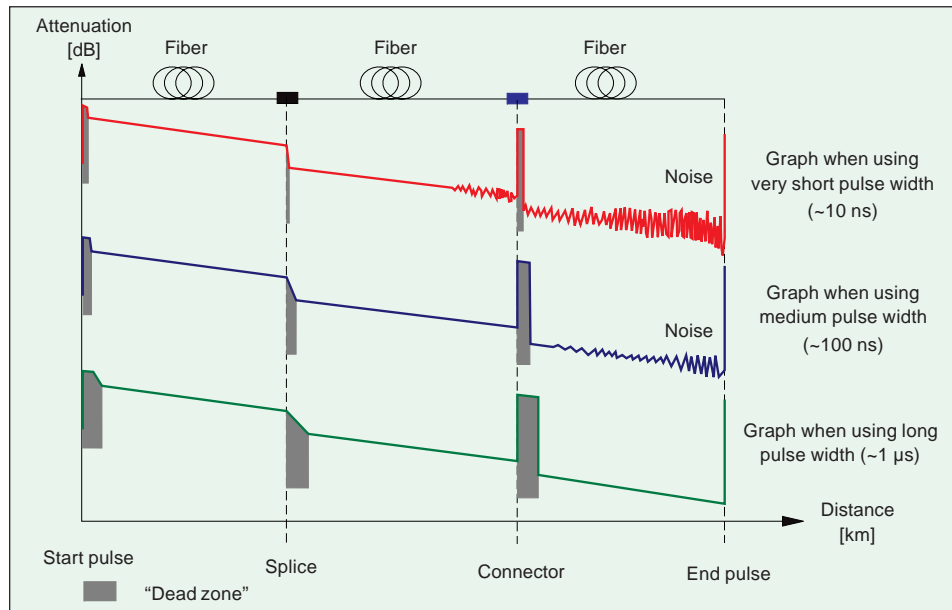

Fig. 10-8 Three graphs with different pulse width showing “dead zone” and noise caused by the pulse width. The time set to the left, is only to give an indication of the time interval commonly used.

Available on the market are OTDRs that dynamically increase the pulse width the longer the measured distance. The sampled graph presented has an equally good quality for the total distance measured.

### Dynamic range

The dynamic range of an OTDR is a measure of how strong the transmitting laser diode (LD) is and how sensitive the receiving avalanche photo diode is. The higher the value is the better the instrument can be used for long distance measuring with high accuracy. Instruments with a high dynamic range are normally much more expensive than the low dynamic instruments. Generally a portable OTDR has a dynamic range to measure up to a 100 km which is more than sufficient for most applications. As an example, for a distance of 100 km the attenuation in the fiber itself will be 35 dB (on 1310 nm) add to this attenuation in ODFs and splices and it can easily be seen that an instrument with a dynamic range exceeding 40 dB must be used. Remember that the signal at the far end must pass a distance double the installation distance (first out then reflected back).

### A few advices

- Minimize the “dead zone” by using short pulse width
- Attenuate the signal if needed, to measure the beginning of the installation
- Minimize noise by increasing pulse width or decreasing attenuation of the signal
- To obtain a better graph use the averaging facility
- For long distance measuring, several intermediate settings must be used, thus creating a beginning, a middle and one last section to get the most accurate picture of the complete installation
- Remember that the quality of all measuring is up to the quality of the instrument and the skill of the instrument operator

## Stabilized light source

A stabilized laser (LD) or light emitting diode (LED) light source is used together with an optical power meter to measure the composite attenuation of an installation, i.e., from connector to connector. The light source comprises a LD or LED module, an automatic power control circuit (APC), a thermo-control circuit, and an oscillator (see Figure 10-9).

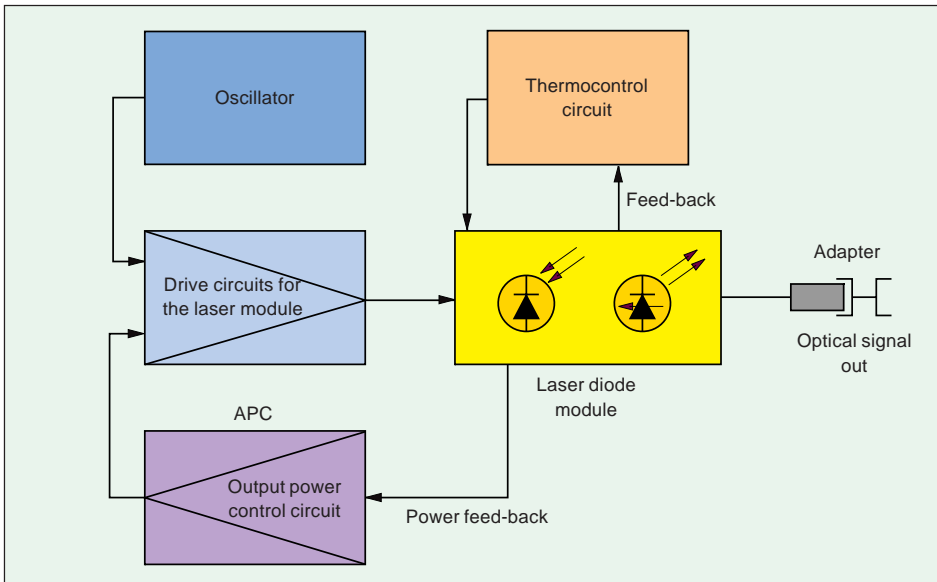

Fig. 10-9 Block diagram of a stabilized light source with laser diode module.

The light from the laser (or LED) module is sent into the fiber via a system of lenses. Light from the rear face of the module is monitored and the value fed back via the APC. This gives a constant output power during measurement. The temperature of the laser (or LED) is monitored and controlled by a Peltier element and the thermo-control circuit, which means that frequency variations are counteracted. Intensity modulation is achieved by means of a built-in oscillator. It should be noted that all light sources require a heating time of around 10 minutes before the laser reaches its operating temperature and a stable output power is obtained.

The light sources used today allow both internal and external modulation of the emitted light. Continuous wave (CW) light should always be used for measurement of composite attenuation in installations.

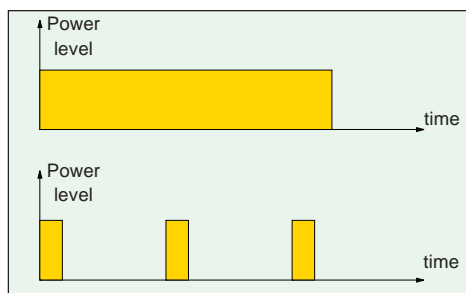

Fig. 10-10 The light from a stabilized light source is often continuous (upper graph), while the light from an OTDR is pulsed (lower graph).

## Power meters and sensors

Power meters and sensors are used to measure the output power of the incident light from both the light source and the installed fibers.

The power meter normally has built-in calibration for the wavelengths most frequently used, but can be calibrated for other wavelengths as well.

On older types of power meters and sensors it may be necessary to recalculate the reading if output power is measured at wavelengths other than 1310 nm.

Different types of sensors (optical receiver) are available depending on the type of measurement to be made and the wavelength range. The sensors normally used permit a measurement range from +10 to -80 dBm. Sensors are normally calibrated for 1310 and 1550 nm. If several power meters and sensors are used simultaneously, they must be calibrated against each other in order to produce congruent results.

## Handheld light sources and power meters

During routine maintenance testing of telecom network installations, and for testing relatively short distance installations, such as metropolitan trunk networks, distribution networks and access networks of all kinds, handheld light sources and power meters are a perfect choice. These instruments are often combination instruments containing both a light source and a power meter in one instrument. Software programs make them very simple to use. Calibration is made by the push of a button. Connected to one another at each end of the fiber to be measured they start to interchange data and results. A very accurate average value is then presented to the operator. These handheld instruments have a somewhat limited range and not the same reliability as those described above.

A common facility in these instrument is that they have a built-in speech channel facilitating the fiber as transmission media. This makes it possible for the operators at each end to communicate with each other.



*Fig. 10-11 Photo showing a stabilized light source and power meter. Both are intended for handheld field use. Photo, courtesy of Anritsu Inc.*

## Measuring with a stabilized light source and power meter

### Practical attenuation measurement

Attenuation measurement is carried out on the installed cable section by means of a stabilized light source and a power meter. Transmission is measured in both directions, at both 1310 and 1550 nm.

The connectors must be cleaned thoroughly before connecting the fibers and taking readings, since a dirty connector can affect the reading significantly.

To prevent the light source's connector from becoming worn out, a dual-connector patch cord should be connected to the output of the light source; the other end of the patch cord should be provided with a bushing. The patch cord must remain connected to the light source for the entire period of measurement (removing it might change the coupling loss readings). Before measurement, the light source and the laser diode module should be turned on for at least 10 minutes (heating time) to ensure a stable light flow. Measurements should be carried out with unmodulated (CW) light.

The light source is placed at the cable's termination point, depending on the direction in which measurement is to be made. A reference value is then obtained from among five separate measurements, i.e., after connection and disconnection of the bushing (see Figure 10-12).

The second lowest reading is selected as the reference value. For example, if the following readings were obtained: -1.82, -2.10, -1.85, -1.92 and -1.88 dBm, **-1.85 dBm** would be selected as the reference value.

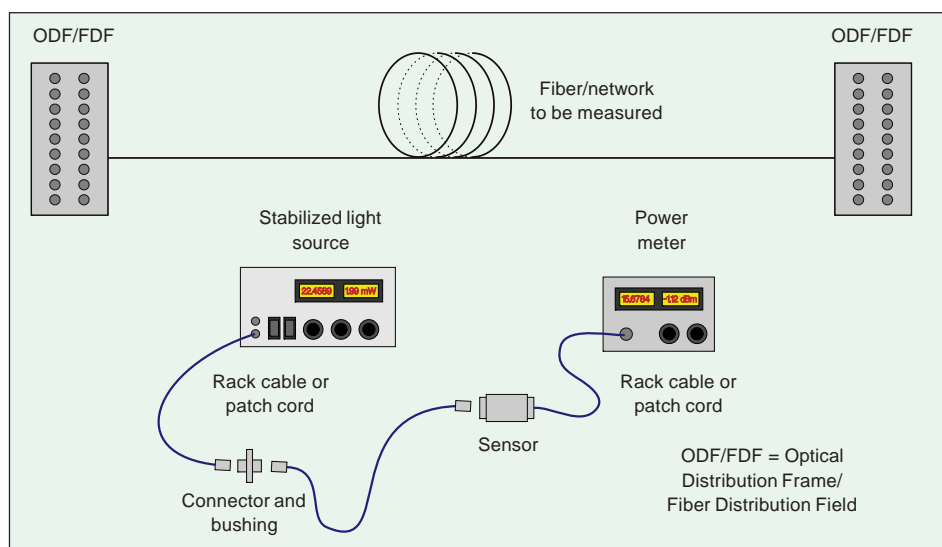

Fig. 10-12 The connection of a stabilized light source and power meter for determining the reference value.

The power meter is then shifted to the other end of the cable installation and each fiber is connected to the transmitter and receiver. Five readings are again taken. Note that the fibers are connected and disconnected at the ODF, i.e., the connection to the light source or the power meter should not be broken (see Figure 10-13).

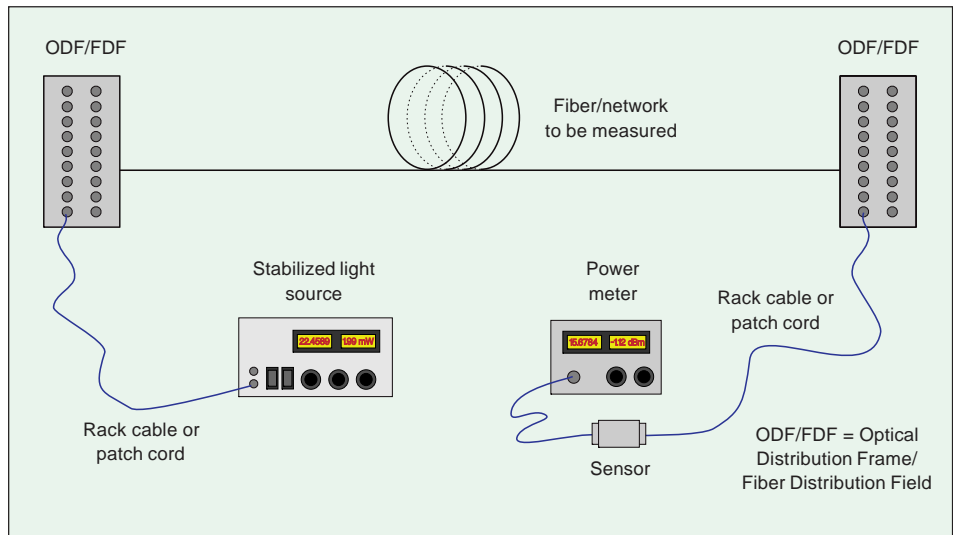

Fig. 10-13 Setup for measuring the cable attenuation of an operational installation.

When all readings have been taken, the attenuation value for each fiber can be calculated. Only the second lowest reading is used in this calculation. For example, if the following readings, -10.56, -10.45, -10.49, -10.66 and -10.37 dBm, were obtained, the value for the calculation would be -10.45 dBm. The total attenuation in the fiber is obtained by subtracting this value from the reference value.

Example:

$$(-1.85) - (-10.45) = 8.6 \text{ dB}$$

The total attenuation including the connectors in the ODFs is 8.6 dB

## Measuring connector and splice loss

“Cut-back” is one of the methods used to measure the quality of a connector or splice. The power  $P_1$ , after passage through a length of fiber, is measured by means of power output measuring equipment. The fiber is then cut and terminated with connectors, or mechanically spliced or fusion-spliced. The power  $P_2$  is measured

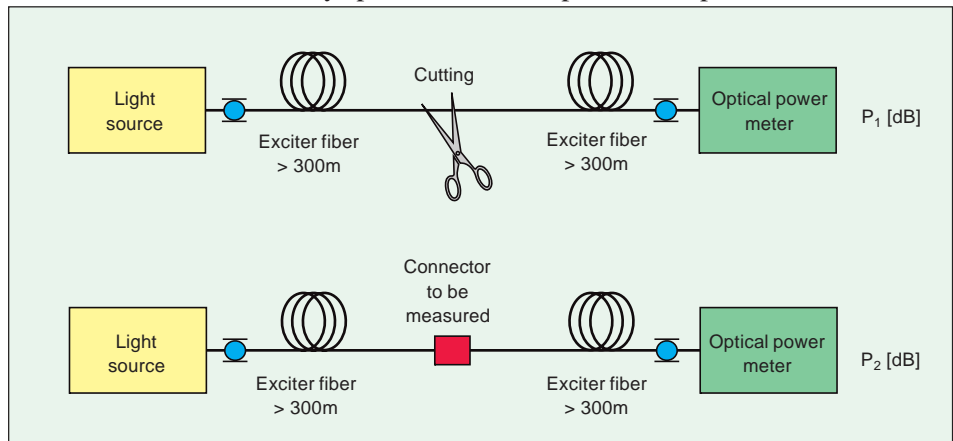

Fig. 10-14 By first cutting the fiber, then terminating it with connectors or splicing it, the losses caused by the fiber itself can be disregarded.

in the length of fiber thus restored (see Figure 10-14), and the loss through the connectors/splice is obtained by subtracting  $P_2$  from  $P_1$ . This method means that the losses caused by the fiber itself can be disregarded.

The standard IEC 60874-1 gives a detailed description of how different connectors and connector parameters are to be measured.

## Test accessories

Field measurements require patch cords with connectors adapted to the connectors available in the installation and on the instruments to be used. For this purpose, special testing kits have been developed for both single-mode and multimode fiber.

A testing kit should consist of at least three single-connector and three dual-connector patch cords, a number of bushings for connecting them together, and a bare-fiber adapter for connecting bare fiber to an instrument's patch cord. To clean the connectors, 96% ethanol and a bottle of compressed air will be needed. Acetone or similar solvents can destroy connectors.

For single-mode-fiber installations equipped with PC connectors, measurement should always be carried out with patch cords terminated with PC connectors.

After repeated connection and disconnection, the alignment surfaces of the bushing will become worn, so care should be taken to observe changes and to replace the bushing as soon as wear is suspected. Normally, the manufacturer will guarantee that a connector can be connected and disconnected 200 times without any noticeable deterioration of its optical parameters.

## Testing an installation

The purpose of testing is to check that the optical fiber cable has been handled and installed in such a way that its quality and transmission characteristics have not been altered.

## Instances of testing

### Delivery testing

Delivery tests are performed at the time of delivery of cable drums from the factory. Drums and cables should be visually inspected to reveal any transportation damage prior to shipment to the work site. This inspection normally takes place at the depot where the cable drums are stored. Measurements are to be taken on all cable drums that are included in the delivery for the project in question. The inspector should also check the identity of the drums against the delivery documents. Optical parameters are measured with an OTDR instrument.

### Measurements are to include:

- Optical length [m]
- Attenuation per unit of length at 1310, 1550 and (1625) nm [dB/km]

## Inspection after laying

An inspection is carried out to check that the cable has been laid in such a manner that it is not subjected to abnormal stress. The measurements taken during this inspection also underlie the warranty given by the contractor responsible for cable laying. All fibers in the buried cable sections are to be measured. The measurements should be made at the earliest one week after the cable was laid to allow the ground to settle. It is also advisable to test the cable when repairs are carried out and in conjunction with the mounting of splice boxes.

Testing is done with an OTDR at both 1310 and 1550 nm and also for the new wavelength 1625 nm. It is especially important to measure the longer wavelength, since it is easier at these wavelength to discover cable subjected to stress and to detect any cable bends with too small radius.

### Measurements are to include:

- Optical length [m]
- Attenuation per unit of length at 1310, 1550 and (1625) nm [dB/km]

## Splice loss measurement

All spliced fibers are to be measured with OTDRs. Readings should be taken at both 1310 and 1550 nm (1625nm); preferably from the cable's termination point, i.e., the exchange, but measurements can also be made from the cable ends or from a splice, if necessary.

Because of the instrument's dead zone it may prove difficult to obtain splice loss readings at termination points and at splices between indoor and outdoor cables. One way of overcoming this problem is to measure a terminal box splice from the outside, i.e., from the indoor cable's other end, for example. The cable should then be laid within the exchange in the appropriate place and the box spliced in at the rack. Measurements are made from the cable drum's inner end. The splice loss reading is obtained with the two-point method. The indoor cable should be longer than 40 m and measurements should be made with a short pulse.

Splices between two different types of cable can also be measured according to the same principle, i.e., measurements made with the instrument placed at the first line splice.

When all fibers are spliced and the box has been closed and mounted in its intended place, all fibers should be tested again and the results checked against the previous values. To allow for this test, the middle splice points should be left disconnected (or unspliced) so that attenuation can be measured from the middle of the fiber to both its ends. When the midpoint is finally spliced, transmission through the fiber is again measured in both directions from the cable end points.

When measuring splice loss in shorter cable lengths, the shortest possible pulse and the two-point method should be used.

Due to the above mentioned problems in measuring splice losses within an ODF-box an acceptable accurate value to be used in documentation is the estimated splice loss value given by the modern type of fiber splicing equipment during splicing.

## Verification of the complete installation

An installation is verified through both OTDR tests and attenuation measurement. Normally, measurements should be taken at both 1310, 1550 and if customer request, 1625 nm. For high performance installations, measurements should be done regarding the PMD value as well.

### OTDR tests

The fibers are measured with an OTDR in both transmission directions and at both 1310, 1550 and (1625) nm. The final splice loss values for each fiber and each splice are recorded. The total length of each fiber is also measured.

The attenuation per unit of length should also be measured. This reading is then used for the testing of composite attenuation. Overview diagrams should be printed out from the OTDR instrument to be included in the installation documentation.

### Attenuation measurement

Attenuation should be measured with a stabilized light source and a power meter, preferably between two exchanges and in both transmission directions. The readings should not exceed the estimated value. The difference between the readings for the fibers in a cable section should not exceed 2 dB if the cable section is longer than 5 km.

## Fault tracing

OTDRs are used for fault tracing. Before measurement is begun, it should be checked that the transmitter and receiver have been disconnected from the fiber to be measured. This is necessary to avoid potential damage to the OTDR, and to the transmitter or receiver.

Network maps, splice plans and possibly overview diagrams are required to facilitate fault tracing. Measurements - primarily on fibers that have caused an alarm or fault registration - are normally made in two stages: first approximate localization and then more accurate pinpointing of the fault.

### Approximate localization

The OTDR should be set up to show the entire cable length on the screen. The pulse length normally used is 1 to 4  $\mu$ s.

If the fiber is broken, the curve will show considerable reflection (end pulse) in the installed fiber, and if there is greatly increased attenuation at an isolated point in the fiber, this will show as a sharp knee on the curve. Such points should then be expanded to provide better reading resolution. The approximate position of the fault is also determined.

It should be noted that if the fiber break is located in a cable section between two splices, the thixotropic jelly filling in the cable will reduce the end pulse.



### Pinpointing the fault

For the final pinpointing of the fault (C), (see Figure 10-15) as short a pulse as possible should be used, and the graph should be expanded maximally around the area where the fault is suspected. After averaging, the distance to the fault is determined.

To determine the position of the fault more exactly, a known point in the cable - such as a certain splice - may be chosen as a reference point. The distance to the fault is measured with the OTDR set to reference measurement. In this way, the distance from the known point to the fault will be obtained.

Measurements are made from both end points to check that the sum of the distances from A to C and from B to C is equal to the length of the faulty cable.

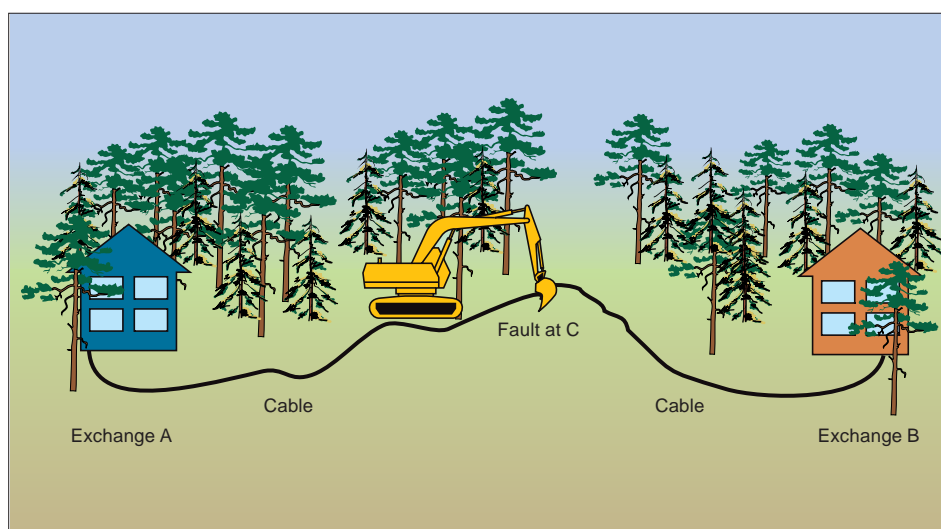

*Fig. 10-15 Pinpointing the fault at C.*

The distance to the known point is determined with the help of network maps and splice plans. The refractive index (IOR) of the instrument should be adjusted so that the distance shown on the instrument is the same as the actual physical cable length. The position of the fault is then measured with the adjusted refractive index value.

After visual inspection and final localization of the fault, the cable should be repaired in accordance with the instructions and guidelines that apply to the particular type of cable.

## Final documentation

Before the completed installation is handed over to the customer, it must be finally documented. This final documentation will form the basis of future maintenance work, and future expansions. Exactly what is to be included in the final documentation should be clearly specified in the agreed contract. Generally, the following documents should be included:

- Delivery testing results
- Measurements after cable laying
- Splice loss measurements
- Verification of the completed installation
- OTDR-printouts
- Protocol from measuring with stabilized light source and power meter.

## Maintenance testing

Maintenance tests should be performed in order to discover and rectify changes in the transmission parameters for a fiberoptic information network. These tests should be scheduled to take place at two-year intervals, for example. All the parameters measured for the final documentation should be included in maintenance testing, and all readings should be checked against the readings obtained during the previous maintenance testing or for the final documentation. All changes should be notified and attended to.

## Summary

Normally, only two instruments are used for the testing of fiberoptic installations. A stabilized light source with power meter is used to determine the total attenuation between two connection points. An optical time domain reflectometer (OTDR) is used to analyze in detail the attenuation in a fiber, per unit of length, for the entire cable section, and for connectors and splices - and to obtain printouts of the installation's "fingerprint". These documents are saved as reference material for use in the routine maintenance testing of the installation.

## Chapter 11

# Installation of optical fiber cable

---

### Introduction

Among the twentieth century's greatest inventions can be counted the method of transforming telephone conversations and other types of analog and digital telecommunication signals into short light pulses, and then transmitting these pulses through extremely fine glass fibers. Light pulses replace electrical signals, and glass fibers replace copper cables. Optical fiber technology for information transfer is having the same impact on telecommunications as did the railroad for transportation during the 19th century.

Through the introduction of fiber optics into telecommunication networks, the user is offered a wider range of services, e.g., telex, telefax, data and broadband services, such as videophone, radio, TV and high definition TV (HDTV). The tremendous impact of Internet in telecommunication introduces the possibilities of interactive services such as distance study through ITV, homeshopping, working from home, information gathering from all over the world, home control, –such a list can be made almost endless.

Success for mobile communication relies on a well planned fiber optic network. Every new generation of services introduced in the mobile network demands a more and more dense fiber optic network structure.

Probably the most significant feature of optical fiber technology is its almost unlimited capacity for transferring information over long distances (exceeding 100 km) without the signal needing to be amplified. And because optical fiber is completely immune to strong electric fields, lightning and electromagnetic pulses (arising from electrical discharges), optical fiber cables can be laid in environments which would be impossible for conventional copper cables e.g. transformer stations, roadbeds, railway embankments, power lines, close to X-ray equipment. Optical fiber cable is also ideal for the transmission of secret information, e.g., for military installations, bank networks and in hospitals.

The trend in optical fiber based networks is increasingly towards the use of singlemode fiber (standard step index, non-zero dispersion shifted or pure silica), primarily where there is a need for high capacity and/or when long distances between points of amplification are required (see Figure 11-1).

Multimode, graded index fiber is used in networks with a limited geographical spread, i.e., local area networks (LAN) inside buildings with up to several kilometers' distance between equipment. Capacity and bandwidth requirements are limited to around 500 - 2 000 MHz×km.

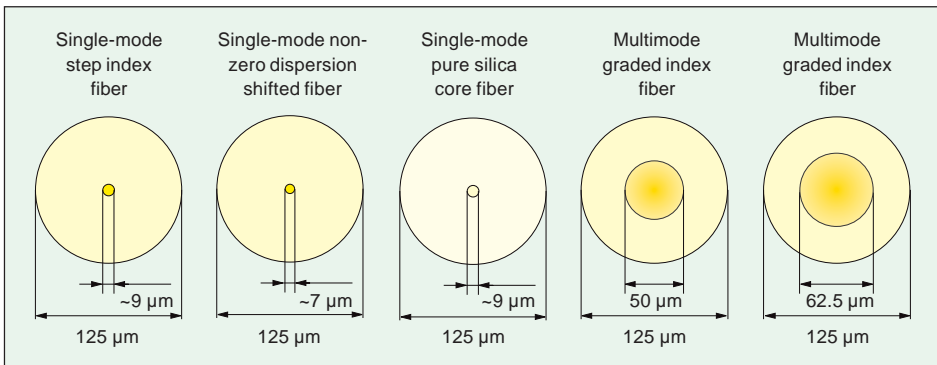

Fig. 11-1 Presented here are five standard types of fiber used in information networks.

Optical fiber cable is considerably lighter and more flexible than copper cable. This means that installation of optical fiber cable is physically less demanding and much quicker (see installation comparison in Figure 11-2). The low weight of optical fiber cable makes it possible to manufacture much greater lengths; up to 8 km is common for outdoor cable for long-distance networks.

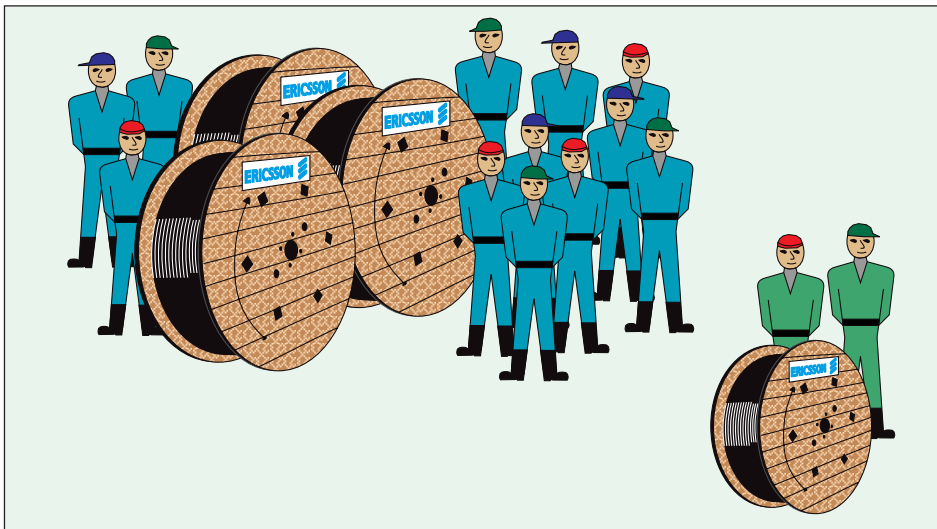

Fig. 11-2 Installation comparison between copper cable (left) and optical fiber cable (right) for long-distance networks.

The tools and techniques for laying copper cable can also be used to a large extent for laying optical fiber cable. However, there are some important differences requiring special caution. An optical fiber cable must **NEVER** be stretched or pulled so hard along its length that the fibers are subjected to tensile stress; neither may the fibers be subjected to a bending radius which is too tight when the cable is bent. Whenever an optical fiber cable is pulled a microprocessor or dynamometer controlled pulling device **must** be used.

Optical fiber cable should be laid so that it is not compressed by earth or in any other way subjected to radial stress. This also applies to indoor cable during renovation and expansion of LANs, for example.

The experience from more than ten years of installation in the most diverse environments has shown that thorough planning is always necessary before installation can begin.

## Direct buried cable

This section provides guidelines for the laying of optical fiber cable directly into the ground (plowing or digging).

In either case, the cable is laid in such a way that it is in direct contact with the soil, gravel, stone and clay. When all matters involving land ownership have been dealt with and the cable route has been determined, the engineering department can plan the laying of the cable in detail. The proposed cable route must be carefully surveyed, staked out and marked on site before any work is begun. Bridges, culverts, buried power cables, gas and water pipes, as well as other telecom cables, should be marked on maps that accurately show the planned position and laying depth of the optical fiber cable and the points at which it will cross the routes of other cables.

Splice boxes and splicing points should be determined and marked. Before plowing or excavation work begins, samples of the soil should be taken along the entire route to ensure that the right type of equipment is used. These samples will also be valuable in filling and complementary work. The need for extra armoring of the cable - or blasting work - must be determined and any such work carried out as required.

When ordering cable, the extra length that will be required for cable loops must be taken into account. The cable must also be sufficiently long to permit splicing above ground. Where the cable is looped, or bent, the bend radius may not be smaller than 15 times the cable diameter (or as specified). Serious damage to the optical fibers can result from bending the cable too sharply.

## Supervision

It is very important that optical fiber cable - whether buried through plowing or digging - should be carefully supervised while supervision is possible. Both methods are relatively quick, and the laying technique makes final visual inspection of the cable's location impossible. Everything must be right, from the very start.

## Plowing

Plowing the cable directly into the ground is the quickest and most economical method of laying optical fiber cable. However, for some types of soil - swamps or marshes, ditch-banks or very stony ground - it may be necessary to bury the cable through digging.

When the plowing method is to be used, always ensure that:

- pre-plowing has been done
- a sufficient amount of cable is being fed
- the cable is being fed without jerks
- the plow is not raised or lowered steeply
- the correct depth is maintained
- the plow is not tilted sideways
- the permitted bend radius is not exceeded
- tension does not build up in the cable.

If the plow needs to be taken up, the place should be exposed by digging. The plow is lowered and raised gradually in the excavated hole to avoid sharp “knees”. If the plow needs to be backed, the cable must first be disengaged so that the plow can reverse without damaging the cable.

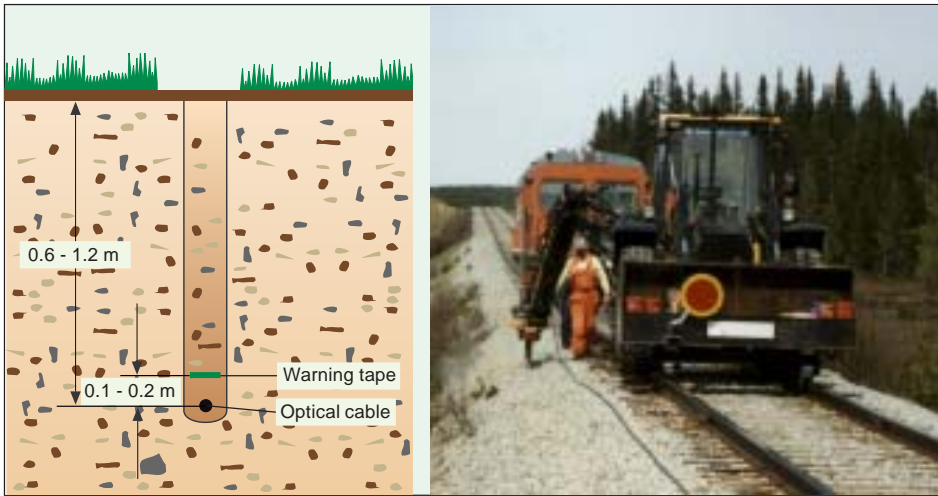

Fig. 11-3 Direct plowing of optical fiber cable with a specially equipped tractor. Here, in the embankment along a railway.

When restarting the plowing after any form of break, the operators should ensure that the cable already laid does not glide backwards (which would expose it to linear strain). The cable should be disengaged from the plow and inspected if it has been subjected to sharp bending or level differences during laying.

In Sweden the plowing technique has successfully been used by both the Swedish PTT (Telia) and the Swedish Railroad (Banverket). More than half of all installed fiber optic cables in Sweden have been laid by this method.

Plowing is a very fast method for laying cable. Directly laying a 6 km length of cable can be achieved in one day. Vibrating plows will not only cut through the ground more easily but will also restore the ground better after laying. These types of plow are recommended when installing cable along railway embankments.

The plowing technique can also be used for laying the ducts that will be used for the installation of duct cables.

Cables to be used with the plowing technique must be equipped with an extra reinforcement such as steel or aluminum wire, corrugated steel tape or heat expandable tape (see Fig 11-4).

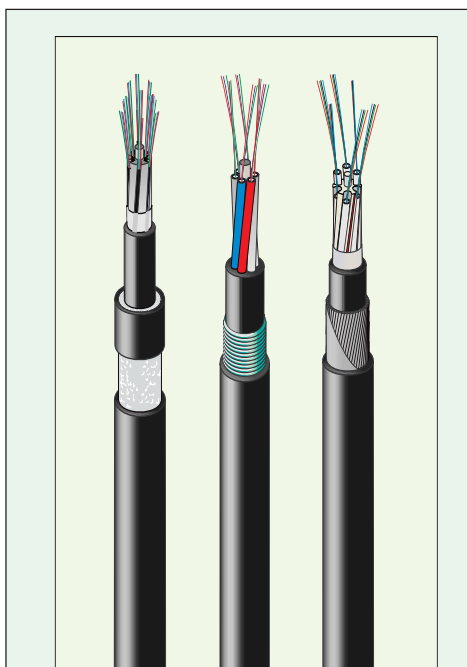

Fig. 11-4 Three typical samples of cables made for direct burial. Left is the HET-reinforced GASLLDV perfect for laying along electrified railroads. In the middle is the GRHLWLV for lighter ground and to the right is GRSLTLV for rough terrain.

## Digging

In cities and towns - and in other places where cables have already been laid - plowing is a less suitable method of laying optical fiber cable. In such areas, a cable trench is required - at least 12–15 cm wide. The bottom of the trench is covered with sand up to a depth of 5 cm to even out any irregularities. The trench should lie in a straight line between the cable's splicing or break points to avoid bending the cable unnecessarily. The cable is then laid in the trench and covered with about 5–10 cm of fine sand. Normally, the cable is laid directly from the drum down into the trench. If it needs to be drawn a greater distance (or under a road, under pipes or under other cables) sharp objects in the ground must be avoided. In situations like these the cable is normally placed in a protective duct. Tension must not be permitted to build up inside the cable.

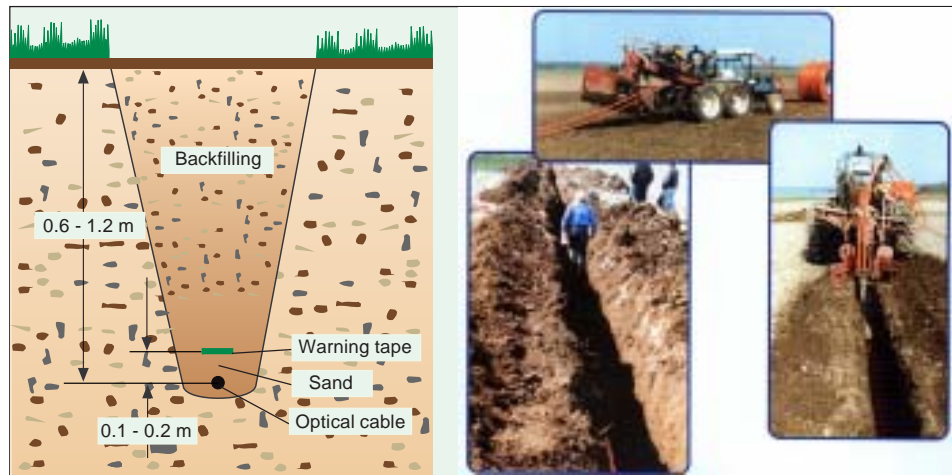

Fig. 11-5 Laying of optical fiber cable with a specially equipped excavating tractor.

The most common method is for the tractor to first dig the trench, and then - with its wheels on either side of the trench - slowly lay the cable along the trench directly fed from the drum.

An alternative method is as follows: The excavating tractor pulls the cable off the drum, alongside the route. The cable drum is disengaged from the tractor, which returns to the starting point and excavates the trench. The cable is then laid in the trench; the tractor covers it and refills the trench. Needless to say, care should be taken to avoid driving over the cable with the tractor.

Cable trenches are normally 0.6–1.2 m deep. Cable in routes through arable land should be buried deep enough so that normal crop farming will not expose the optical fiber cable to any danger.

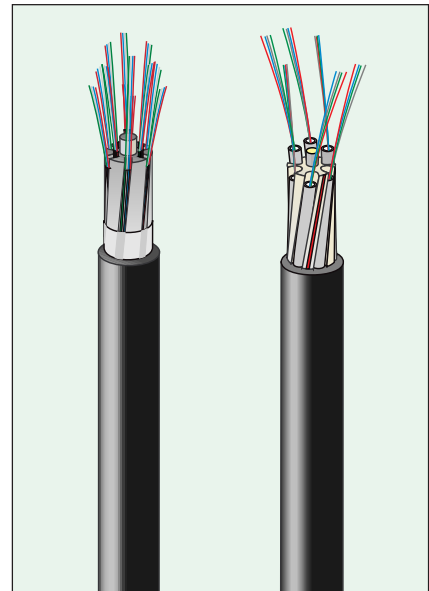

Fig 11-6 Two duct cables the can be used for direct burial installation if precautions are taken, GASLDV and GRSLDV.

It is recommended that cables to be used for direct burial installation are recommended to have an extra reinforcement like the cables for plowing, see Fig. 11-4. To reduce the cost for the cable, duct cables that contains a central slotted core profile can be used in the direct burial installation. Extra precautions must be taken by surrounding the buried cable with at least 10 cm of sand before the backfilling is done.

### Warning tape

An aluminum or plastic tape with a warning text is placed 15 - 20 cm over the optical fiber cable, so as to prevent excavation damage to the cable.

## Installation in cable ducts

When laying optical fiber cable in cities, it is practical to use existing cable ducts (pipes or tunnels). Detailed instructions for the installation must be prepared after careful on-site investigations along the entire path of the cable.

Instructions should indicate what work needs to be done before the laying operation is started: manholes in need of repair, cable racks required, cleaning of ducts or repair of damaged ducts, or just a tidying-up along the entire cable route.

To minimize the risk of damage to the cable during installation, the pipe system, other cables in the tunnel or pipe, and the ducts in which the cable is to be laid, should be inspected. Level differences and other positional shifts should be avoided. Normally, optical fiber cable is laid in a separate duct. If this is not possible, it may be laid together with other telecommunication or electric cables without any of these affecting its performance.

The capacity of a wide duct can be increased through the use of PVC tubing as a subduct. This makes future expansion of the cable network much easier, since previously installed cables need not be disturbed (see the section on subducts below).

### Subducts

As has been mentioned already, the capacity of wide cable ducts can be significantly increased by using a system of subducts. Up to four 30 - 33 mm PVC tubes can be inserted in a normal 100 mm duct. The advantages are apparent when a cable needs to be repaired or replaced, or if more cables are to be installed later.

When using subducts, the maximum number of PVC tubes that can be inserted into a duct should be installed at the same time and secured at both ends.

Figure 11-7 shows four cable ducts with subducts of PVC tubing inserted. Poorly secured tubes will probably cause problems when cable is subsequently laid, since the tubes will then move

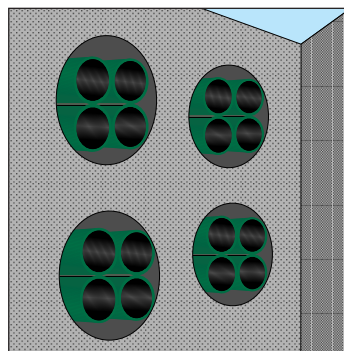

Fig. 11-7 Ducts with subducts inserted.



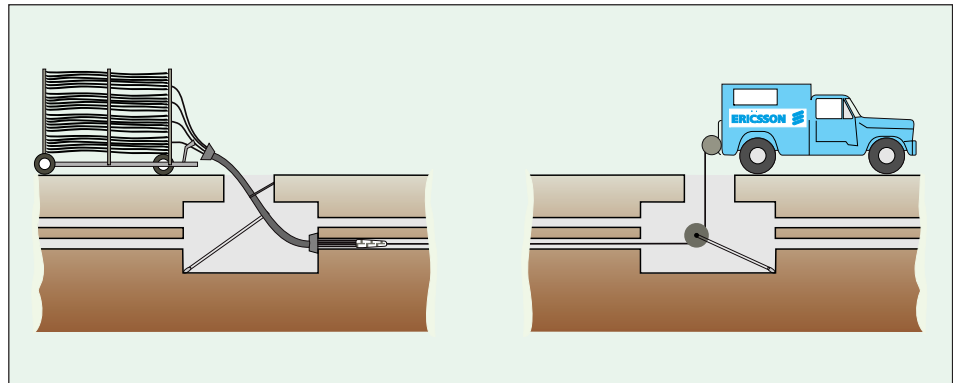

Fig. 11-8 Insertion of PVC tubes as subducts in a primary duct.

inside the duct. The use of subducts permits the laying and replacement of cables without affecting or damaging other cables in the duct.

## Different methods for installing the cable into the duct

The following method is suggested for installation of cable in ducts.

- Traditional pulling by using a pulling rope
- Blowing with compressed air
- Floating with water

Only the first method, traditional pulling will be described in detail. Important for all methods is that the duct to be used must be layed properly. This means that it should be layed with a minimum of bends. All duct splices must be made carefully to avoid sharp edges between the ducts. For the use of compressed air or water the attainable installation distance depends very much on the quality of work done. Distances between 4–6 km are possible without splicing the cable, thus saving a lot of time.

### Traditional pulling

If the cable route has many sharp bends, the cable drum should be placed close to these bends, in order to reduce the pulling force on the cable during the laying process.

When a cable is laid in a duct, it is normally guided from the drum into the duct (i.e. past the edges of the manhole opening) through a plastic or steel pipe. This pipe is also used to apply grease: The cable can be lubricated with a suitable lubricant to reduce the friction between the cable sheath and the duct. Figure 11-9 shows the application of lubricant in a typical manhole installation.

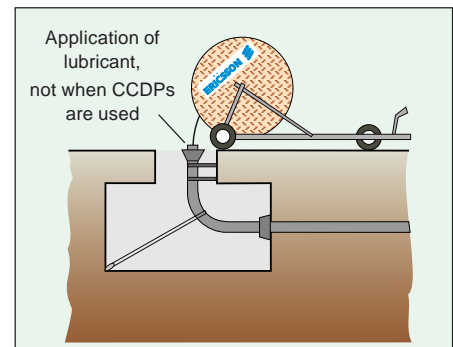

Fig. 11-9 Installation of cable with simultaneous application of a lubricant.

During installation, simple corner blocks and cable drums are used to ease the cable over sharp bends and to bridge level differences between the manhole's inlets and outlets.

The cable is drawn through the duct by means of a non-ductile rope. A swivel prevents the cable from being twisted.

Specially adapted towing eyelets should always be used for fastening the pulling rope to the cable. The towing eyelet must have a pulling link for fixing the cable's strength member (see Figure 11-10).

If the cable route has many sharp bends, the cable drum should be placed close to these bends, in order to reduce the pulling force on the cable during the laying process.

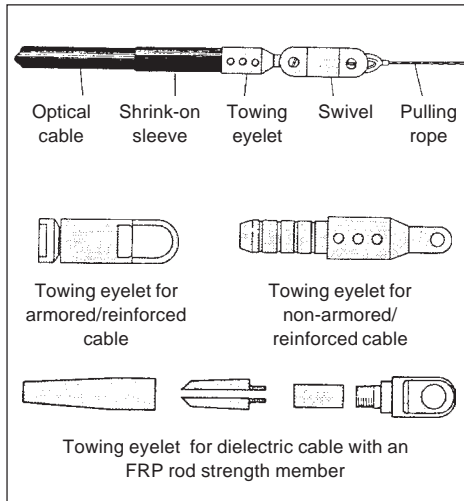

Fig. 11-10 Different types of installation device.

Cable sections with a length exceeding one kilometer should be laid by placing the cable drum in the middle of the laying section; then laying one half of the length of cable up to one of the splicing points. The remaining length is then wound off the drum and laid up to the other splicing point. To use this method, there must be sufficient space above ground to be able to wind the cable off the drum. Special care must also be taken to protect the exposed cable from being driven over by trucks or other vehicles (see Figure 11-11).

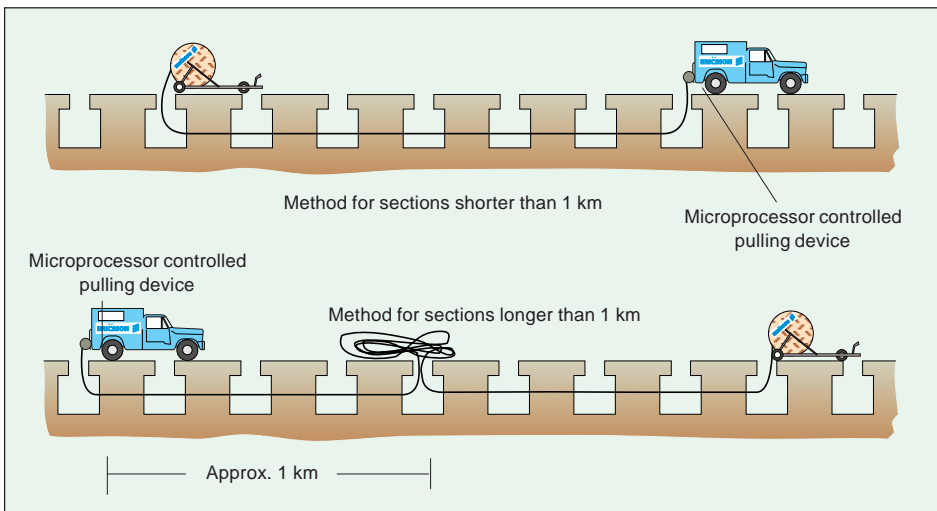

Fig. 11-11 Suitable methods of cable laying in ducts.

If the method just described is not practicable, CCPDs (Caterpillar Capstans Pulling Devices) can be used instead. The CCPDs - purpose-built pulling devices that are anchored to the ground - should be positioned at appropriate intervals (see Figure 11-12). The cable is drawn through the duct by means of motor-driven bands that lie hard against the cable sheath.

By synchronizing the operation of several CCDPs, lengths of up to several kilometers can be laid. CCDPs with powerful electrical or hydraulic pump motors may be used anywhere in the field; they may also be equipped with a small, portable gasoline-driven power supply.

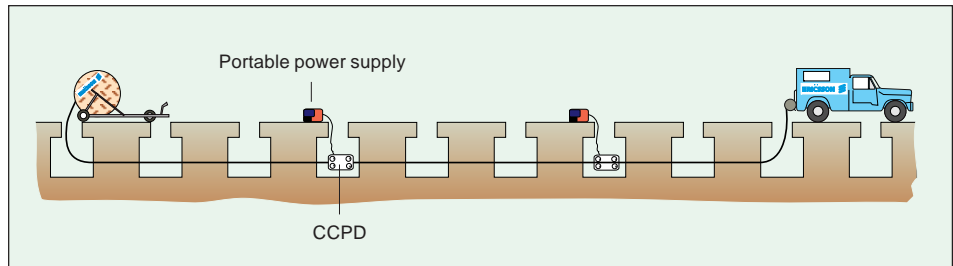

Fig. 11-12 The use of CCDPs (Caterpillar Capstans Pulling Devices) in the laying of long cable sections.

The pulling force applied to the cable must be carefully monitored throughout the laying operation, to prevent the cable from being subjected to excessive axial strain during any part of the pulling process. Purpose-built winches for the laying of optical fiber cable are available. These winches normally use an electric motor with variable speed transmission from 0–30 m/min. Figure 11-13 shows a cable winch for optical fiber cable laying.

The pulling force on the cable is monitored by microprocessor-controlled equipment on the winch. This equipment can be preset to prevent the maximum permissible pulling force from being exceeded. In some cases, a record of the pulling force, pulling speed and pulling length may be printed out directly on a built-in printer.



Fig. 11-13 Microprocessor-controlled winch for cable laying in ducts. (Photo, courtesy of Riteco AB)

### Pulling forces

To simplify the installation of cables into duct, much effort has been put into reducing friction thus allowing longer cables to be used. Friction between the cable and the duct increases in proportion to the length of cable being installed. Formula 11-1 gives an approximate value for the force that must be applied to pull a cable through a straight duct.

$$F=10 \cdot \mu \cdot m \cdot l \quad \text{Formula 11-1}$$

F = pulling force [N]

$\mu$  = friction coefficient between duct and cable

m = cable weight [kg/km]

l = cable length [km]

**Calculated example**

Calculate the pulling force applied to a 1 km GASLDV cable, with a weight of 180 kg/km when installed into a duct. The coefficient of friction between the duct and the cable is 0.35 (a typical value between PE-PE).

Formula 11-1:

$$F = 10 \cdot \mu \cdot m \cdot l \Rightarrow 10 \cdot 0.35 \cdot 180 \cdot 1 = 630$$

The pulling force will be 630 N

**Effect of bends in duct installation**

When during a duct installation the cable route rounds a bend the accumulated pulling force before the bend will increase significantly when passing the bend as described below.

$$F_{out} = F_{in} e^{\mu \Phi}$$

Formula 11-2

$F_{in}$  = accumulated pulling force before bend

$F_{out}$  = pulling force after bend

$\Phi$  = bending angle in radians

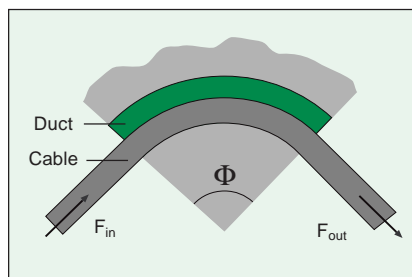
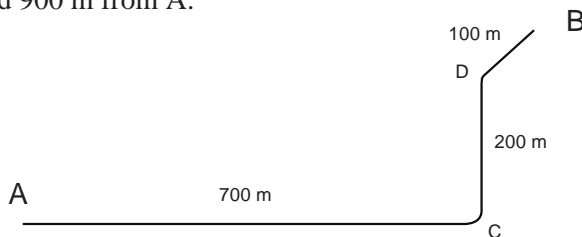

Fig 11-14 Illustration of pulling forces through a bend

For the above values a bending angle of 90 degrees will give an increase of 1.73 and 45 degrees will give 1.32

**Calculated example**

Same installation as above but with a 90 degree bend at 700 m from A and a 45 degree bend 900 m from A.



Calculate the applied pulling force when pulled towards B.

From A to C (700 m):

$$F = 10 \cdot \mu \cdot m \cdot l \Rightarrow 10 \cdot 0.35 \cdot 180 \cdot 0.7 = 440$$

$$\text{After the bend: } F = 440 \cdot 1.73 = 763$$

$$\text{To the next bend D (900 m): } F = 763 + 10 \cdot 0.35 \cdot 180 \cdot 0.2 = 890 \text{ N}$$

$$\text{After the bend: } F = 890 \cdot 1.32 = 1175 \text{ N}$$

$$\text{To the end: } F = 1175 + 10 \cdot 0.35 \cdot 180 \cdot 0.1 = 1238 \text{ N}$$

If the calculation is done for an installation in the opposite direction the force will be 803 N.

Conclusion: Bends in an installation will increase the pulling force. This force also depends on the pulling direction. Pulling from A to B increased the force with nearly 100 percent. In direction B to A with only 27 percent !!

In Figure 11-15 the pulling force for a number of different installation methods, is shown graphically. Illustrated are conventional pulling, pulling with intermediate CCDPs, compressed air with tight plug, compressed air with plug that lets a part of the air pass between plug and duct wall and finally floating with water.

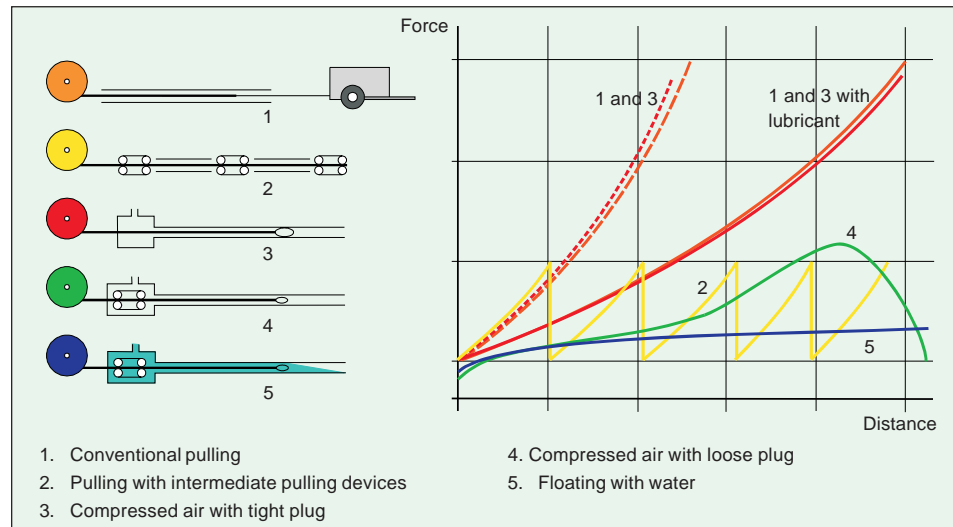

Fig 11-15 Graphs showing relative pulling forces for different installation methods.

## Installing duct cable using compressed air or floating with water

As described in Fig 11-14 the pulling force can be reduced significantly by using either compressed air or floating with water.

### Compressed air

There are two ways of applying compressed air for installing cable into the duct. The first method is to have a tight fitting the beginning of the cable this results in an installation similar to conventional pulling. The compressed air functions as the pulling rope. In this case there is no gain in pulling distance compared to the conventional pulling method. The only advantage is that no pulling rope is needed.

If on the other hand the plug is loose fitting and will let the air pass between the plug and the duct wall, the streaming air will “carry” the cable through the duct and in fact the pulling force will decrease when reaching distances above 1–2 km. Installation distances up to 5–7 km have been reported. The attainable distance depends on the amount of compressed air, the quality of the duct installation and the type of cable.

Figure 11-16 shows the type of equipment needed. The compressed air enters the duct through a special valve that is fixed to the duct. The cable enters the valve on the opposite side through tight fitting gasket. The cable is pushed into the duct by a “cable cat”. The amount of compressed air need depends on the size of the duct and the size of the cable.



Fig 11-16 “Cable cat” in connection with compressed air equipment  
Photo: Courtesy of Sahlins, Sweden

### Floating with water

Instead of compressed air, water can be used. Almost identical equipment is used as can be seen in Figure 11-17. The plug is of the tight fitting type but as the cable density is similar to the density of water the cable will float through the duct, thus experiencing no or very little friction. Once again it must be emphasised, that the quality of laying and installation of the ducts is the main factor for reaching long cable installation lengths. The remaining water in the duct can be blown out by compressed air. Floating with water is the most gentle method for installing cables into ducts.



Fig 11-17 Floating with water, equipment set-up.  
Photo: Courtesy of Sahlins, Sweden

### Cables for duct installation

As described in chapter 5 “How to choose the right optical fiber cable” there is a large variety of cables intended for duct installation to choose from. There is the concentric cable GRHLDV that needs the full protection of the duct, but also the GASLWLV that only uses the duct to ease the installation.

Figure 11-18, shows different types of duct cables.

- the concentric cable, GRHLDV, with up to 144 fibers in 12 loose tubes,
- the slotted core cable, GASLBDV-S, with 24 ribbonized fibers, intended for both outdoor and indoor use
- the slotted core cable, GRSLDV, with 48 fibers in 6 loose tubes
- the slotted core cable, GASLBDV, with 192 ribbonized fibers, intended for both outdoor and indoor use
- the slotted core cable, GASLWLV, with 192 ribbonized fibers, intended for both outdoor and indoor use, this cable has also a corrugated steel tape as extra protection against rodents etc.

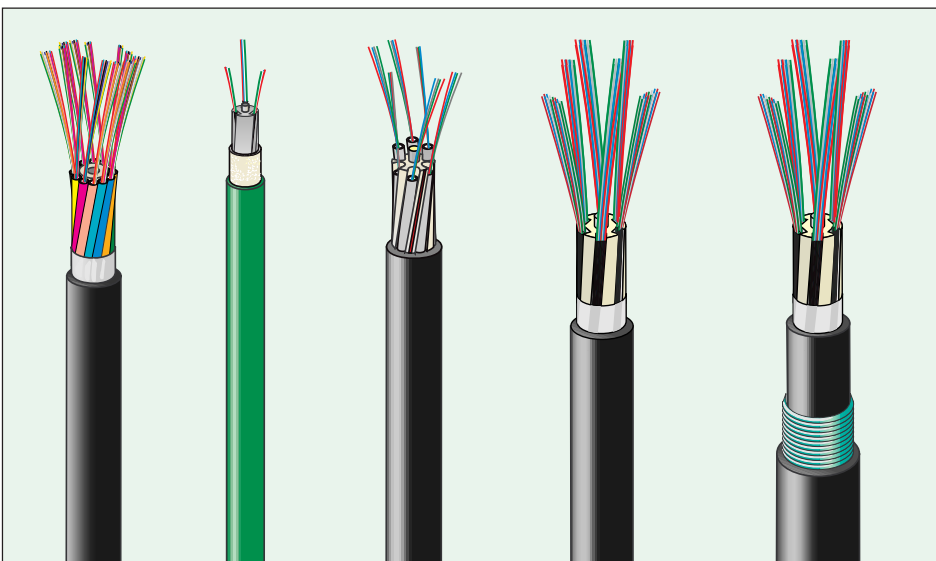

Fig. 11-18 Typical examples of different duct cables.

## Precautionary protection of optical fiber cable in manholes

Normally, optical fiber cable requires no extra protection in manholes between splicing points. However, if it is anticipated that some major work is to be done in any of the manholes, the cable may be fitted with extra protection in the form of a split PVC or PE tube placed over it. Cable clamps or cable stripes should be used for fixing the tube to cable racks or suspension fittings.

Installed optical fiber cable should be marked with self-adhesive warning tape which clearly states that the cable is operational and that special care must be taken.

## Installation of aerial optical fiber cable

Generally, it can be said that there are currently two different methods of installing aerial optical fiber cable. The first method requires that the cable be armored during the manufacturing process - in such a way that axial strains do not affect the transmission capability of the optical fiber. This is called self-supporting cable. The second method means that existing cables or wires (the ground wire in a high tension installation or a railroad electricity network) are used as points of suspension for the optical fiber cable. The two methods have resulted in two different manufacturing procedures dealt with in chapter 5 entitled “How to choose the right optical fiber cable”.

If the terrain permits, a motor vehicle can be used to position the cable along the intended route. The cable is then laid on installation rollers temporarily fitted to the transmission line’s suspension structures, and finally placed onto permanent

fixing devices at the top or along the poles of the structures.



Fig. 11-19 Installation roller

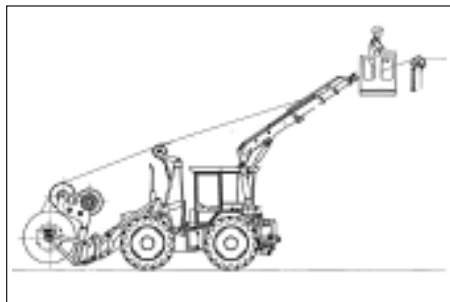

Fig. 11-20 Motor vehicle to ease the installation of aerial cable



Fig. 11-21 Permanent fixing of the cables at the top of the pole.

## Self-supporting aerial cable

It is recommended that the distance between suspension structures should not exceed 1 km. Intermediate supports should be arranged between the suspension points in such a way that the maximum allowed span width for the cable is not exceeded. Even if long cable sections are used (4–8 km), the cable should be fixed every kilometer. The permissible pulling force for aerial cable and the recommended sag in meters are

listed in the instructions from the cable manufacturer. Modern cable winches (see Figure 11-24) have microprocessor controlled settings of pulling forces. To even



Fig. 11-23 Fixing device for self-supporting cable.

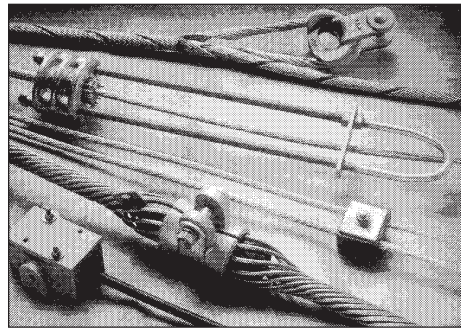

Fig. 11-22 Guy-grips and different cable fixing devices

out the differences in pulling force, the sag should be equally distributed along the length of the entire cable section between splicing points. Fixing devices, normally called guy grips, are used to fix the cable at each intermediary suspension structure, see Figure 11-21. Guy grips are galvanized clamps in the form of a long double spiral, see Figure 11-22. The diameter of the spiral decreases when the spiral is stretched, which means that the cable will be secured to the fixing device. Other fixtures used are the same as those used for conventional cable.



Fig. 11-24 Gasoline powered winch for installing aerial cable.  
Photo: Courtesy of Sahlins, Sweden.

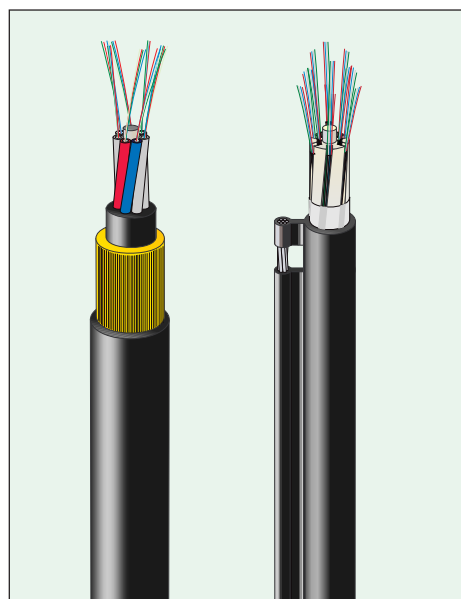

Fig. 11-25 Two samples of self-supporting aerial cable. To the left is a dielectric self-supporting cable and to the right is a cable utilizing a suspension wire.



## Installation of aerial cable by lashing or wrapping

The simplest way of installing aerial cable is to suspend it from an existing cable (in a power transmission or telecommunications line), from the return circuit of a railroad power line or from a special suspension strand. The optical fiber cable is lashed to the other cable or suspension strand, see Figure 11-26. This technique is relatively simple and quick, and is identical to the technique that has been used for conventional copper cable for over a hundred years. The distance between lashings should be 50–60 cm.

If the optical fiber cable is relatively heavy, clamps of galvanized sheet or UV-resistant plastic may be used instead of lashing wire. Over the years, the cable's own weight may result in damage to the sheath. Non-metallic lashing cord must be used if the cable is lashed to existing high power lines.

Wrapping the optic cable around the ground wire or phase wire is a means to cover both short and extremely long cable spans. This relatively new technique has rapidly become very popular. As the electric power companies have seen the possibility of further utilize their power networks not only for electricity but also for telecommunication. They have for more than a hundred years planned and administered the power networks; the planning and construction of a telecom network is much the same. Wrapping the optical fiber cable around power lines in an existing network has given them, in many countries, the position of the second largest network operator only surpassed by the PTTs.

The planning and preparation is very simple compared to ground installation. The installation is carried out by the wrapping machine that moves along the power line (ground wire or phase wire). The installation starts from the middle of a 2–3 km section. The cable is placed on two drums. One of the cable drums is placed on the wrapping machine which then is lifted up to the power line. After attaching it to the power line the machine is either pulled by hand or by a small gasoline motor in one of the installation directions. During the movement the machine twists the cable drum around the power line (wrapping) with a pitch of 50–60 cm. After completing the installation in one direction the machine is removed from the power line and transported back to the starting point where the installation in the other direction is carried out. Installing 2–3 km is typically done in one day. The cable is finally spliced to the cable of the next section.



*Fig. 11-26 Lashing optical fiber cable along a railroad. The cable is lashed to the neutral wire.*



*Fig. 11-27 Wrapping the optical cable around the high voltage power lines.*

## Laying of submarine cable

During the last few years the number of submarine fiber optic cables installed has increased rapidly. The never ending need for more bandwidth, higher bitrates and longer installation distances without amplifiers and/or repeaters has really favored the installation of submarine cables. The demand for bandwidth is met by wavelength division multiplexing and non-zero dispersion shifted fiber. High bitrates are met by new types of lasers and receiving equipment. Long haul communication is achieved with the help of erbium doped fiber amplifiers (EDFA).

Long haul communication (2.5 Gbit/s or more) sometimes exceeding 300 km are today possible without the need for intermediate electronic equipment. Connecting coast-line near cities with submarine cables are often a more cost-effective alternative than the direct burial or even aerial installed cable.



*Fig. 11-28 Especially equipped vessel for laying submarine cable (Telia's Pleijel).*



*Fig. 11-29 Oil-rigs using submarine cable along the pipe-line for remote control of production.*

*Photo: Courtesy of Statoil, Norway*

Many oil-rigs along the coasts are connected to the mainland by repeterless submarine cable systems. The production control is then supervised from mainland instead of having crews onboard the platform. The oil-rigs are also used as intermediate transit points in order to bridge long distances between the mainland and islands (The Carribian, Indonesia etc.) or between countries (Britain–Norway etc.)

## Planning

The laying of submarine cable requires detailed preparations for all the phases involved. Optical fiber cable does not differ significantly from conventional cable in this respect.

Optical fiber cable is much lighter than copper cable, extra weight is therefore introduced by heavy steel wire armoring of the optical fiber cable. The armoring also protects the cable against anchors, trawlers, damage from submerged rocks etc. As the submarine cable will be laid permanently underwater, a metallic water-proof sheath of copper or aluminum is added between the optical fiber cable and the steel-wire armoring. This extra sheath protects the optical fiber from the ingress of water and hydrogen.

A common method for protecting the submarine cable is to plow or water-jet a trench in the seabed in which the cables is buried. At the coast the cable is conveyed in a trench thus protecting it in the shallow waters and from ice in areas subject to freezing conditions.

Cables and splice materials for use underwater at a depth of several hundred meters are being developed to match manufacturers own cable designs.

For submarine cable, each individual installation has its own special problems that often require unique solutions, which means that no specific rules can be given. Close co-operation between the network operator, the installation company and the cable manufacturer is always advisable.

## Cable and jointing equipment

As already described in chapter 5 “How to choose the right optical fiber cable” the construction of a submarine cable is a very complicated task. The jointing of a submarine cable introduce new parameters such as extreme strength and pressure tolerance. The fewer the number of joints the easier and safer is the installation of the cable. If cables can be delivered in lengths of several hundred kilometers in a single length without the need for field jointing, much time and trouble is saved. Ericsson has developed a submarine cable with up to 192 fibers and a delivery length of up to 300 km, pre-jointed at the factory.

The submarine joint closure is made of corrosion resistant alloy (normally stainless steel or copper). A number of gaskets makes the closure water-proof. The joint closure is filled with filling compound to withstand the enormous pressure from the surrounding water at depth down to several kilometers.



*Fig. 11-30 The submarine joint closure SJC 240 ready to go down.*

# Installation of access networks

## Access network

Today the access network is mostly based on the old copper cable network installed during the 20th century. As mentioned previously the new interactive applications will demand a high capacity network. The need for capacity seems to double every 12 month or even faster. To manage this exceptional increase in capacity demand, the copper based access network is now being replaced by optical fiber based networks.

Building and fire safety standards in most countries require that the fiber optic cables are non-flammable, so as not to spread fire in buildings. The sheath is therefore made from self-extinguishing, flame-retardant, halogen-free polyethylene (PE). These types of cable are described in chapter 5 “How to choose the right fiber optic cable”.

The ultimate access network is of course two or more single-mode fibers all the way from one end user to another end user. This would create a revolution in telecommunication but in the mean time we will see a lot of hybrid solutions.

## Different types of access networks

### Fiber to the home (FTTH), the all optical access network

Fiber to the home, the ultimate access network? To change the telecom network from the twisted-pair copper cable to a complete optical fiber based network may be one of the largest challenges at the beginning of the new millenium. Changing to a high capacity fiber optic network is not only an investment in cables, but also in exchanges, receiving and transmitting equipment, hardware and software must be developed an so on.

If a single-mode fiber pair is used, this type of access network will give an almost unlimited capacity. The limitation in such a network is set by the opto-electronic equipment. A special method for installing such an access network will be described later in this chapter.

An intermediate fiber optic access network will be based on multimode technique, owing to the higher cost for single-mode opto-electronic components.

### Fiber to the desktop, FTTD

This network is identical with FTTH but is used in officies

### Fiber to the curb, FTTC

A type of access network that will utilize copper cables for the last hundred meters. The optical fiber cable is used from the switch, router etc. to a central point in the block and terminated in an optical netowk unit (ONU). From the ONU different types of copper cable will be used:

- standard twisted pair copper cable
- coaxial cable (cable-TV)
- high quality copper cables such as cat-5, cat-6 and cat-7
- power cables

## An all optical access network

A complete optical access network is a network where a single fiber or a fiber-pair covers the complete distance from an Access Node to the User Node outlet in the apartment, house or office, see Figure 11-31. This Figure describes the most elegant network solution where no active components are used between the access node and the user node.

By the planning phase the access network must incorporate all possible connections within the area covered by the access node. This is to minimize the costs for excavation and the installation of ducts and to avoid the need to upgrade this part of the access network at a latter stage.

The same applies to the passive parts, fibers and cables. If all end users (homes, apartments and work-places) are connected to the fiber distribution field at the access node by a single fiber or a fiber-pair by the first installation phase, money will be saved in the future as the passive network will be complete and active equipment can be installed incrementally.

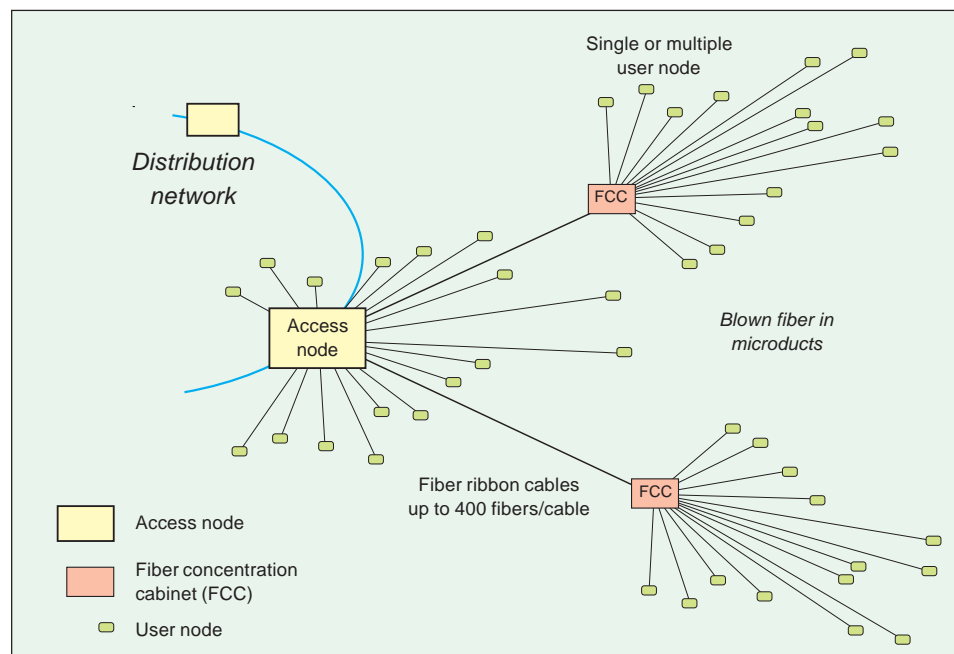

Fig. 11-31 Drawing illustrating one possible solution for a FTTH network.

### Planning

To plan such a network is a delicate task. It must be done with CAD-programs developed entirely for this purpose. The Ericsson engineering support system, ESS is such a program. The program must be able to import drawings of buildings as well as city maps. All connections will be marked on the drawings and the program will produce the best allocation of both the trunk cables, distribution nodes, distribution cabinets, microducts and connector panels. The program will also create an estimate of the costs.

## Traditional indoor installation of an access network

Large buildings of several stories often house large numbers of both high power cables and cables for information transfer. These cables are normally laid on racks or in special ducts on each story of the building. Cable-risers connect the different stories. It is very important that optical fiber cable does not end up under heavy cables in these ducts and risers - optical fiber cables should always lie uppermost! The specified minimum bend radius must be observed, since no bends with a smaller radius are permitted. One should also ensure that the optical fiber cable is laid where it will NOT, under any circumstances, be damaged by trucks, rolling wagons, chairs, tables, etc.

Cables laid in risers between several stories must be anchored every meter so that they do not become exposed to longitudinal pulling forces. Clamps with a soft inside surface must be used for fixing the cable in place, this to minimize damage to the cable sheath and fibers.

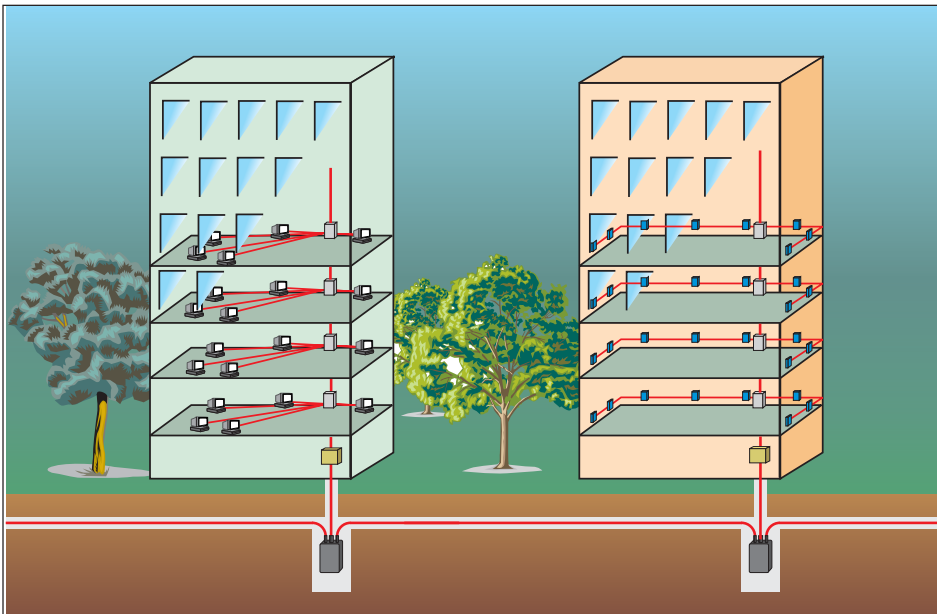

Fig. 11-32 Traditional indoor cabling. To the left is a starlike network shown and to the right is a bus network. Trunk cable to each floor and plenum cable to the user.

## Blown fiber installation technique, Ribbonet®

The blown fiber technique was invented at the end of the 1980s. Ten years later this technique has been developed further by Ericsson Network Technologies. The blown fiber concept can be divided into five steps, see also Figure 11-31.

- planning
- installation of microducts
- installation of trunk cables to distribution cabinets
- installation of fiber ribbon by blowing
- installing of opto-electronic equipment

### Microducts and installation of microducts

The microduct is a halogen-free and flame retardant plastic tube. The outer diameter is less than 6 mm and the inside of the duct is covered with an anti-static layer. Several microducts can be put together to make a multiduct. For outdoor installation a layer of aluminum foil is added as moisture barrier and a second PE-sheath is added. If the microducts are to be directly buried a third layer of HDPE is added as a protection against damage during backfilling.

The installation of microducts is quite strait forward and will be done by building workers or electricians both in old properties and properties under construction. The idea behind using microducts is that the fiber can be blown in at any time on demand. The microducts can be installed separately or in combination with power cables, TV cables or twisted-pair cables. Finally, the fiber ribbon can easily be replaced without the need for reopening installation routes.

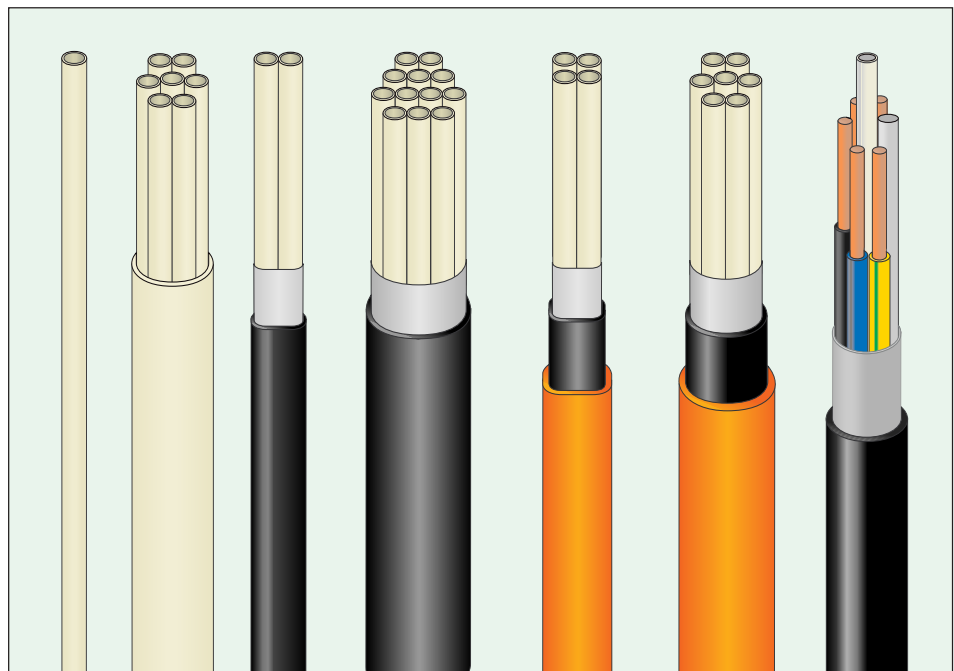

*Fig. 11-33 Microducts. Left, two microducts for indoor installation next two for outdoor installation. The two orange microducts are for direct burial installation and the cable to the right is a combined power cable including a microduct for blowing a fiber or fiber-pair.*

### Installation of fiber ribbon by blowing

After all microducts and splice cabinets have been installed the blowing of fiber ribbon can begin. A fiber optic access network is to be seen as the high end of any network performance. Since the fiber connections are a prime factor for quality it is strongly recommended that pre-terminated fiber be used. Pre-terminated fibers also minimize installation time at the user site. The fiber ribbon is stored on a reel. Figure 11-34. At each apartment, desktop etc. the outer end of the fiber ribbon is blown into the microduct in the direction of the access node. A process that takes just only a few minutes. In splice cabinets (if installed) the fibers are fusion spliced to a ribbon cable. This will concentrate the fibers and brings down the network costs for longer distances, see Figure 11-31.



Fig. 11-34 Reel with fiber ribbon and blowing tool.



Fig. 11-35 Splice cabinet. 48 microducts are terminated and 48 2-fiber ribbons are spliced within the cassettes to the left. The green 96-fiber ribbon cable enters the cabinet at the bottom.

### The access node

In the access node the fibers in the distribution network (the city ring) are connected to switching or routing equipment. This makes it possible for several service providers to access subscribers in the access network.

In large fiber distribution fields (FDF), the fibers from each user in the access network will be connected to the active equipment. The new IT-infrastructure will be described in detail in another chapter (planned).

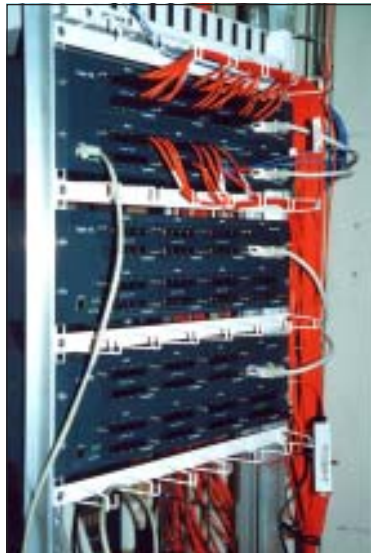

Fig. 11-36 Access node for incremental connection of more than 150 user nodes with transmission capacity of 100 Mbit/s per user node.

### Installing opto-electronic equipment at the user site

At the user premises the ribbon fiber terminates in a wall-outlet. The wall-outlet will also accommodate the small opto-electric switch to which the different electronic equipment in the premises can be connected through a standard local area network.



Fig. 11-37–11-39 The wall-outlet with opto-electric switch



The Figure 11-40 illustrates one apartment building to the left and one office building to the right. In the apartment building the termination of the microducts is in the splice cabinet located in the cellar. In the splice cabinet the fibers are spliced to the outdoor cable which connects to the fiber distribution field at the access node.

For the office building, to the right in the figure, the microducts are terminated at each floor in the splice cabinet due to the high fiber count. The fiber-pairs from each workplace are spliced to a multi-fiber cable that run all the way to the access node. The cost for the access node can be shared among the different companies within the office building.

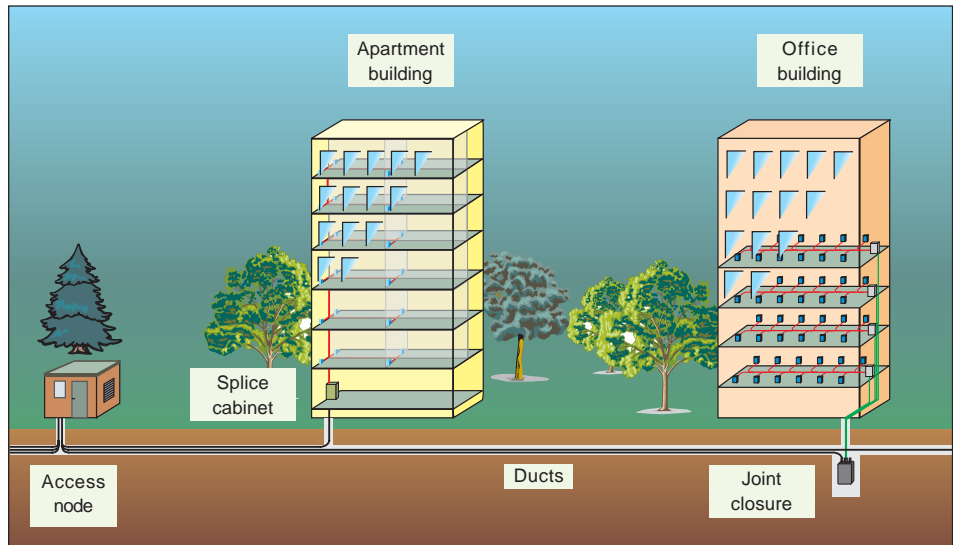

Fig. 11-40 Illustration with one apartment building and one office building entirely cabled with the blown fiber concept.

## Finally on access networks

All planning for an access network must be done with the fiber to the home concept in mind. The regional/metropolitan and the distribution will be accessed through access nodes. Never underestimate the number of fibers that may ultimately be needed.

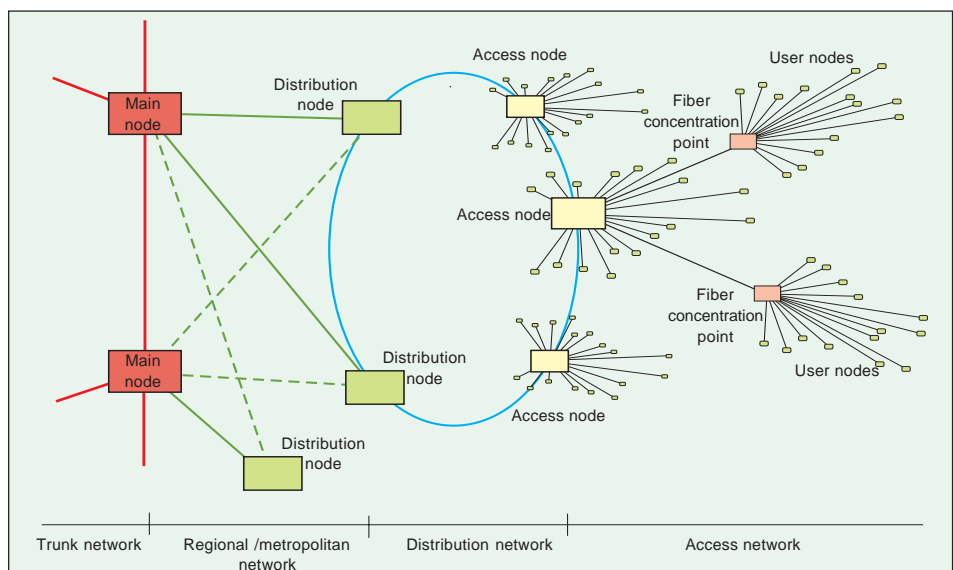

Fig. 11-41 The access network is a part of the all fiber optic IT-infrastructure

## Splicing and the splicing environment

As soon as the cable sections are laid, they should be spliced along the entire length of the route. The technique to be used for splicing will depend on the type of cable and transmission requirements. Short cables without special demands for low attenuation and high transmission speed may be spliced mechanically with a variety of semipermanent connectors or mechanical splices. In long-distance networks with single-mode fiber, much more reliable methods are required that will ensure low attenuation. The most frequently used and safest method of splicing fibers is fusion splicing. For further information, see the chapter entitled “Optical Fiber Splicing”.

Fusion splicing is internationally recognized as by far the best method of splicing fibers. With this method, a splice is obtained that - given normal conditions - will last the entire life of the fiber. If any form of mechanical splicing is used there is always the risk of a deterioration in the transmission capabilities of the fiber link.



Fig. 11-42 Specially equipped vehicle for splicing optical fiber cable in the field.

A fusion splice gives a splice loss of 0.1–0.15 dB (according to ITU/CCITT, the maximum acceptable splice loss value is 0.2 dB measured as an average in both directions of transmission). In a mechanical splice, the best loss value that can be obtained is 0.3–0.4 dB, and this requires that index-matching oil is injected into the splice. Unfortunately, the oil dries up after some years and the splice loss may then increase to over 1 dB.

Splices may be made either above ground in specially equipped vehicles or in tents. Splicing may also be done underground in manholes or shafts. It is important that all splicing work be done under very clean and temperate conditions. The ambient temperature should be in the range 10 - 30°C to prevent building temperature-dependent fiber tension into the splice.

A good working environment is very important, as the work is precision-dependent and a splice is to last for up to 40 years. (Dwelling for a moment on time and capacity aspects; the fact is that up to a million telephone conversations per second will pass through each splice - and probably even more in the future - as well as TV channels, multimedia Internet etc.) If the work is done in a manhole or tent, and a fan is used for ventilation, the air should be filtered to avoid small particles from contaminating the splices.

The use of a specially equipped vehicle like the one shown in Figure 11-42 has many advantages:

- The time for setting up the fusion equipment at the location is reduced
- Tools and splice materials are always near to hand
- Splicing can be done in a controlled environment, which contributes to the quality of the splice
- Excess cable can be wound in and protected in a manhole or shaft.

Optical fiber cable laid in the ground can be handled in the same way as conventional cable, except as described above. At each splicing point, the splice box and any excess cable should be placed in a large cement ring.

Aerial optical fiber cables should be spliced on the ground. The splice box and any excess cable is then fixed with special clamps high up on the suspension structures. If the cable cannot be spliced at ground level, it will be necessary to use some form of sky lift.

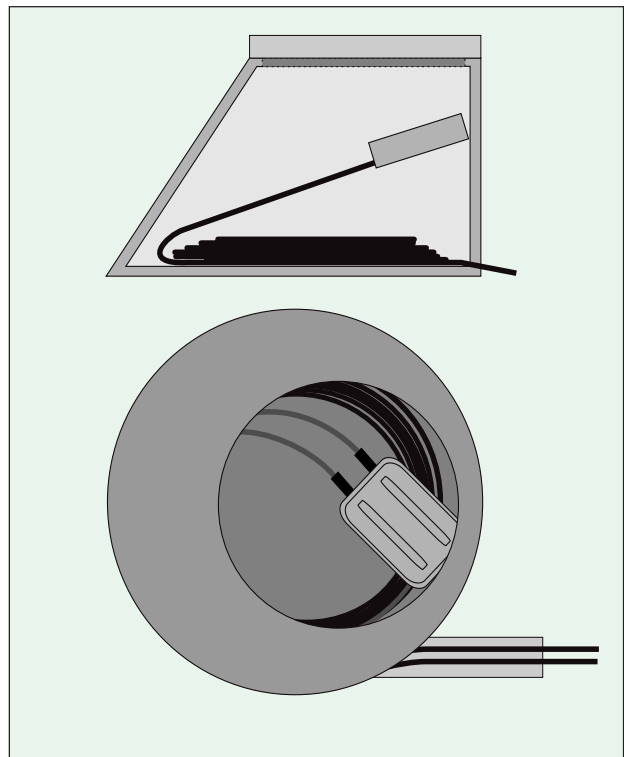

Fig. 11-43 Excess cable is wound up and placed in a concrete ring (outdoor cable).

## Joint closures

A protective joint closure for outdoor optical fiber cable should:

- be easy to handle and install
- be easy to open and seal again without a large amount of material being needed for resealing
- provide very good mechanical protection of the fibers even under severe conditions
- provide the same protection for armored and non-armored cable
- provide the same protection for different cable sizes
- provide protection for cables in ducts, buried cables, and aerial cables.

### A variety of joint closures

Ericsson Cables provide a variety of splice boxes. They are all intended for outdoor use, but can without any problem also be used in indoor installation. All joint closure should be submersible to withstand flooding. Normally, it should be capable of withstanding a hydrostatic pressure corresponding to 6 m depth of water for a short period without the water penetrating the box. Careful installation work is necessary for this requirement to be met. The capacity regarding number of fibers to be spliced is different for each joint closure.

#### NCD 503

The joint closure NCD 503 is made of acidproof stainless steel. The standard closure can house up to 6 fiber cassettes (organizers) each with a capacity of 12 single fibers or 6 fiber ribbons. With an extra high cover it will house up to 8 fiber cassettes.

The cables enters the joint closure through bushings that are mounted to the closure with nuts. The size of the bushings can easily be tailor made according to customer specification thus making this box very versatile, see figure 11-44.

The NCD 503 can be used as a line joint, butt joint, for midspan access or as a termination box. It can be mounted on walls, in manholes, cabinets, racks or be buried directly in the ground.

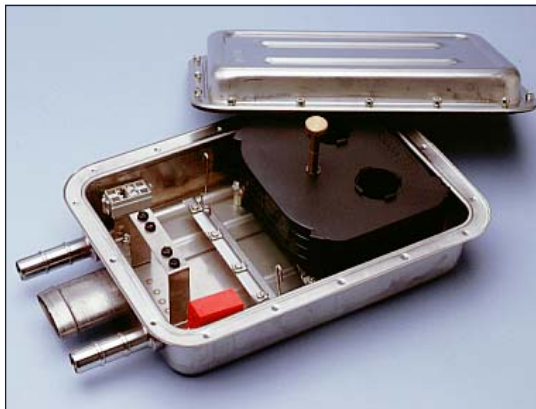

*Fig. 11-44 Joint closure NCD 503 all in acid-proof stainless steel.*

#### NCD 504

An all plastic alternative to the joint closure NCD 503 is the NCD 504. It is made of black PPO (Noryl). All plastic part are flame retardant according to UL94 V-0 classification. The standard closure can house up to 8 fiber cassettes (organizers)

each with a capacity of 12 single fibers or 6 fiber ribbons. The standard closure has three cable entrances. The two outer are circular to allow one cable each, to enter the closure. The entrance in the middle is elliptically shaped and will accommodate up to three cables. If the number of cable entrances is insufficient an extension ring can extend the capacity with another 4 cables and 4 fiber cassettes.

The NCD 504 can be used as a line joint, branch joint, or for midspan access. It can be mounted on walls, in manholes, cabinets, racks or be buried directly in the ground as the NCD 503.



Fig. 11-45 Joint closure NCD 504

**NCD 505 1004**

The joint closure 505 1004 is a small fiber optic in-line closure that can handle up to 4 incoming cables and 48 single fiber splices.

The closure comprises a plastic outer shell, a rubber seal and two end caps. This closure is intended for in-line jointing of cables compared to the two butt joint closures NCD 503/504. Each of the two end caps have two cable ports and one threaded, metallic feed-through. The closure can be pressurized.



Fig. 11-46 Joint closure NCD 505 1004

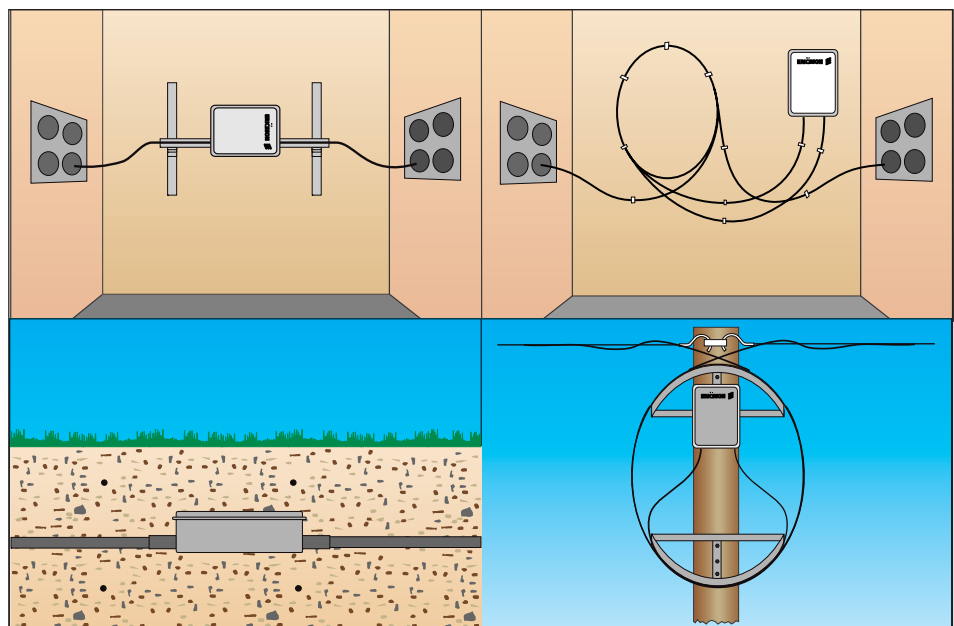
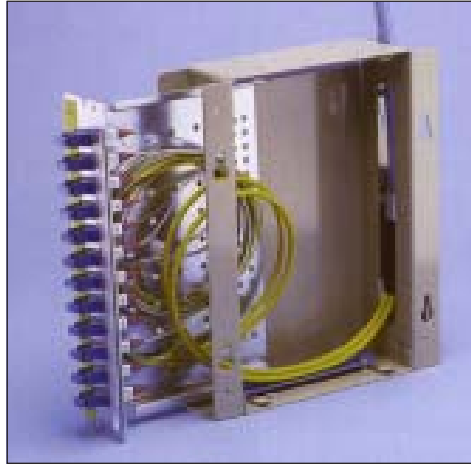

Fig. 11-47 Different alternatives of installing a splice box: in a manhole, on a riser, underground and on a pole.

## Line terminals and Optical Distribution Frames

The Line Terminal (LT) or the Optical Distribution Frame (ODF-box) Or Fiber Distribution Fields (FDF) is the interface between the transmission equipment and the optical fiber network. At the point in the network where the fiber from the transmission equipment meets the fiber from the access/trunk network, there must be some type of cross-connection to facilitate cable rearrangements, measurements and fault location of optical lines. The main function of an LT, ODF or FDF system is to organize and terminate fiber at this point.

In principal, the signals from the trunk, local exchange or radio base station are converted to optical signals in the transmission rack (see chapter 1). The transmission rack can either contain a built in LT (see Figure 11-48) or ODF system (see Figure 11-49) or the FDF system (see Figure 11-50 and 11-51)



itself can be designed as a separate unit. *Fig. 11-48 Pre-terminated line terminal or termination unit*

### LT, ODF and FDF

The LT and the ODF is normally adapted for one or two incoming multifiber cables with a total of 48 fibers. When a large number of fibers are terminated the expression Fiber Distribution Field is introduced.

Splice sleeves and the necessary excess fiber are placed in special cassettes so as to be easily accessible for future reconfiguration of the network. LTs and ODFs for single-mode fibers are normally delivered pre-terminated with a customer specified number of meters of indoor cable, ready to be installed next to the transmission equipment. The fibers are terminated with different types of connectors, primarily FC/PC or SC connectors or multi-fiber connectors like the MT or MTRJ connector. This ensure the highest quality and performance of the connection to the network. All connectors should be polished according to specifications and undergo a 100 % check regarding their optical values. This can not be done with “on site” assembly.



*Fig. 11-49 Pre-terminated ODF.*

For transmission systems utilizing the fiber ribbon concept the FDF equipped with the MT-connector can easily accommodate several thousand fibers. An alternative to the MT-connector is to split the ribbons into single fiber “fan-outs” and terminate the split fiber ribbon into standard single fiber connectors thus limiting the number of fibers to be terminated.

The LTs, the ODFs and the FDFs can be installed in 19" racks. The front can be pulled out when installed, this facilitates connection work and cleaning of the connectors.



*Fig. 11-50 and 11-51 To the left is a fiber distribution field that can accommodate 960 MTRJ connectors for fiber ribbon thus resulting in termination of 2 000 fibers or more. To the right is a termination unit with 96 connectors.*

## Summary

In all long-distance networks, and nowadays even local networks, copper cable for telecommunication is being replaced by optical fiber cable. The methods applied in the manufacture, laying and installation of optical fiber cable represent a well-known and proven technology.

To meet the requirements from network operators, network installation companies and network designers, Ericsson has a well-developed organization that is constantly refining splicing techniques, splicing tools and machinery so that these always fulfil the requirements of both cable manufacturers and cable designers.





## Chapter 12

# Rare-earth doped fiber amplifiers

---

Anne Lidgard and Torbjörn Carlnäs

### Introduction

A major new technological evolution is taking place in optical fiber telecommunications. Until recently, the classic method of compensating for losses along a transmission line has involved the use of repeaters. A repeater is a device based on hybrid technology, including both electronic and optical components. It detects the light signal, equalizes the wave or reshapes the pulse electronically, and then regenerates a modulated optical signal which is reinjected into the fiber. The capacity of a network or long-haul transmission line utilizing this type of repeater is limited by the electronics. The logical direction of research has therefore been to eliminate the electronic stage and to develop a technology based on all-optical amplification. One concept has been based on the use of a semiconductor laser operating below the lasing threshold. Depending on the facet reflectivity, it can be made to operate in either travelling-wave or in resonant (Fabry-Perot) mode. The first demonstration of optical signal amplification in a semiconductor laser diode was reported in 1973, using a pulse operated GaAs laser diode. Until 1989, the major part of research efforts was invested in developing this technology.

In the eighties, singlemode fiber became a standard telecommunications transmission medium for 1.3 and 1.5  $\mu\text{m}$  wavelength signals. At the same time, interest in optical fiber began to revert to the fiber's role as a potential active device in the system. Work on rare-earth doped silica fibers, reported by groups at Southampton University in the UK, played an important role in reawakening the field, which - with a few exceptions - had been dormant ever since the work of Snitzer and Koester in the beginning of the sixties. In 1987, the use of erbium-doped fibers as amplifiers for 1.5  $\mu\text{m}$  signals was reported by a Southampton group and later the same year by a group at AT&T Bell Laboratories. At that point, some essential features of the concept of fiber amplifiers had successfully been demonstrated: the existence of a dopant (erbium) which, in a silica host, has an emission wavelength at room temperature coinciding with a standard communication wavelength (1.5  $\mu\text{m}$ ), and the existence of manufacturing techniques that allowed doped fibers to be made with reasonable doping levels without creating excessive background loss that could curtail the gain.

For the second transmission window, i.e. signals at 1.3  $\mu\text{m}$ , attempts to find a suitable host-dopant combination have been less successful. The obvious choice of Nd-doped silica proved to be a less than ideal combination, for two main reasons: the transition is peaked near 1.34  $\mu\text{m}$ , approaching the OH resonance peak; and the potential gain is restricted due to a parasitic effect called *excited state*

*absorption*. Work on other host materials is more promising; in particular, fluoride fiber doped with praseodymium has shown good amplifying qualities, and the first practical devices have already been introduced. However, fluoride fiber has its drawbacks in that it poses serious technological problems in fabrication and splicing. This chapter will focus on erbium-doped silica fiber, although some of the content - in a general sense - applies to all doped-fiber amplifiers.

An important contribution to the rapid progress of the erbium-doped fiber amplifier (EDFA) was the development of a high-power semi-conductor laser operating at 1.48  $\mu\text{m}$  to be used as an intra-band pump. Hence, the feasibility of a compact, high-performing device for all-optical amplification was proven, and the fever quickly spread to nearly all corporate telecommunications laboratories around the world, as well as to many universities. In 1990, the major conferences in the field had sessions exclusively dedicated to erbium-doped fiber, and the number of papers published on this topic abounded. In 1992, several commercial suppliers of complete erbium-doped fiber were offering amplifier modules, ready to be plugged into optical fiber systems. This great progress can in part be understood by looking at be attributable to some of the main advantages of the EDFA:

- It is easily integrated into a fiber-based transmission system
- It provides high gain: >50 dB has been reported
- It is highly efficient, giving 30 dB of gain for only around 20 mW of pump
- It is strongly immune to crosstalk
- It is intrinsically polarization-insensitive
- It has a high saturation output power, > 15 dBm
- It has a low noise figure, typically 4 dB
- It is modulation-format and bit-rate independent, allowing system upgrades

In the following sections, the theory of operation is outlined and the fabrication processes are briefly described. The various types of EDFA are investigated, considering the application aimed at in each specific case. Finally, the role of fiber amplifiers in the development of optical telecommunications is analyzed.

## Theory of operation

### General

The idea behind the optical amplifier is rather simple:

- Erbium, a rare-earth element, is introduced in the core of a silica fiber in its trivalent ionic state,  $\text{Er}^{3+}$ . The erbium ions are excited into a higher energy state by absorbing photons provided by an external light source, called pump. This energy is then transferred to the signal as it propagates in the erbium-doped fiber. The mechanism whereby the energy is transferred is called, *stimulated emission*. It is the same mechanism as that used in lasers.

The pump light is guided into the erbium-doped fiber by means of a wavelength-division multiplexer, as shown in Figure 12-1:

A number of well-defined wavelengths can be used. This is best illustrated by the energy diagram of  $\text{Er}^{3+}$ .

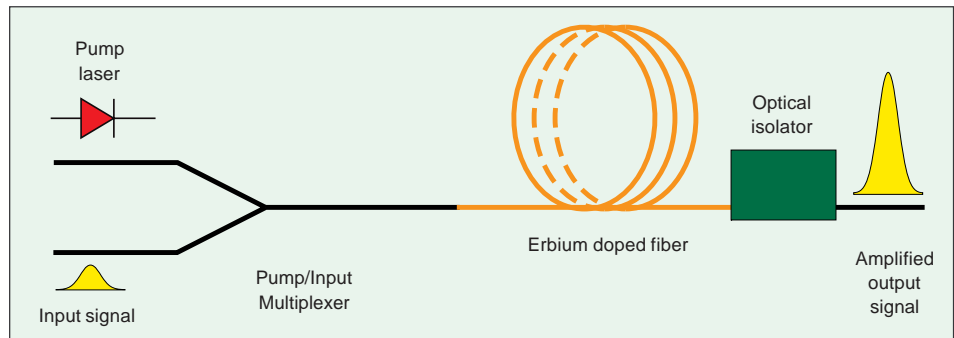

Fig. 12-1 A typical amplifier with erbium doped fiber

From the higher energy levels, the erbium ions decay mainly through phonon vibrations until they reach the  $^4I_{13/2}$  metastable level. This energy level is called metastable because of its relatively long lifetime, 10 - 15 ms. Input signals consisting of photons with energies matching the  $^4I_{13/2} - ^4I_{15/2}$  energy gap will stimulate the ions in this latter level to relax by emitting photons equal in energy and in phase to the signal photons, resulting in analog amplification of the total signal power.

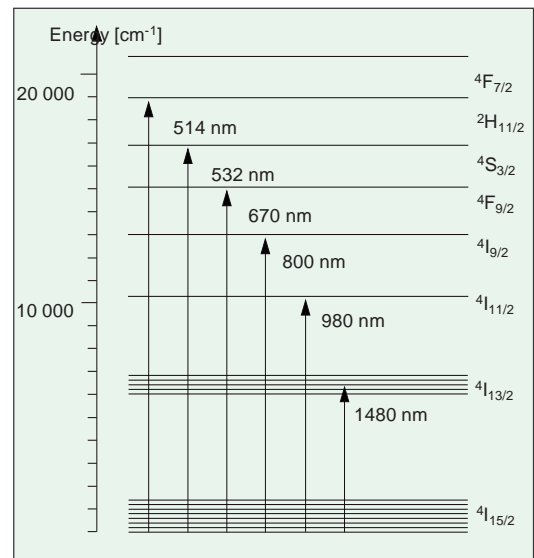

Fig. 12-2 Energy levels of erbium ions in a glass host material.

The erbium ions also decay through spontaneous emission. Since the light from the spontaneous emission is inherently included in the gain bandwidth, it too will be amplified, giving rise to what is called *amplified spontaneous emission*, ASE, Figure 12-3. ASE is the main source of noise. In certain applications, filters are used to reduce this noise.

Today, the pump wavelengths most frequently used are 980 nm and 1480 nm, since they are both highly efficient and allow the use of commercially available semiconductor diode lasers as pumps.

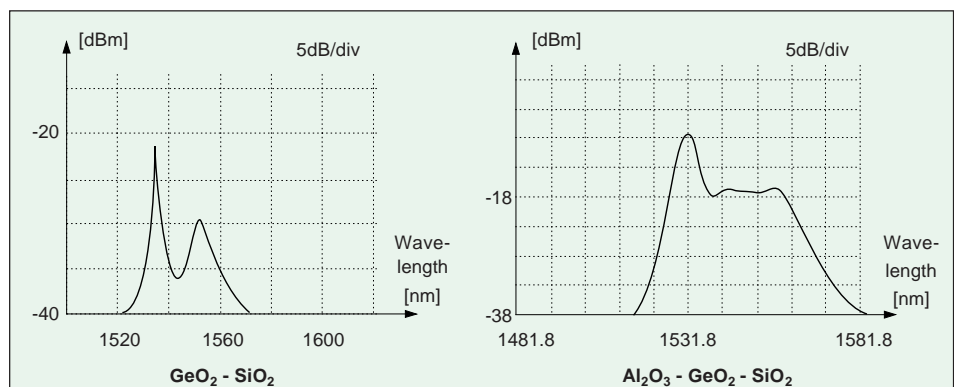

Fig. 12-3 Amplified spontaneous emission of  $Er^{3+}$  in different host materials:  $GeO_2 - SiO_2$  to the left and  $Al_2O_3 - GeO_2 - SiO_2$  to the right.

The isolators are included to prevent counter-propagating light from disturbing the lasers and from building up inside the amplifying fiber, causing it to self-lase.

## Key Parameters

There are of course numerous optical parameters that characterize a specific fiber amplifier. For practical system design purposes, all are not relevant and many may even be difficult to interpret. However, the following parameters should be considered:

- Gain
- Gain bandwidth
- Signal output power
- Noise figure

### Gain

Gain, when specified by the amplifier manufacturer, is simply the difference in dB between the signal input power and the signal output power, including the WDM and isolator excess losses, but excluding the splice loss that arises when the amplifier module is connected to the transmission line.

Small-signal gain obtained in the laboratory exceeds 50 dB, whereas typical figures in commercially available amplifiers are around 30 dB.

### Gain Bandwidth

The gain bandwidth can be specified in different ways, but the important information to be extracted is the maximum deviation from the specified gain within a certain wavelength interval. Often a graph is shown with the gain plotted versus the signal wavelength for a specific input power level. This is useful in selecting the center wavelength of the transmitter (given certain tolerances) and for multi-wavelength transmission applications. As can be seen in Figure 2-3, previous page, adding aluminum as a co-dopant tends to broaden the gain bandwidth, giving  $\pm 0.5$  dB of gain deviation over more than 30 nm.

### Signal Output Power

Due to saturation effects, the gain compresses when the signal input power reaches a certain level. The amplifier is then no longer operating in *small-signal regime*, but rather said to be in *saturation mode*. It is important to know how much signal power can be extracted from the amplifier for a specified pumping level. In the literature, the most common definition of saturation output power is the signal output power at which the gain has been compressed by 3 dB compared to its small-signal value. Other definitions, stating a value of 6 dB, have also been presented. Commercial suppliers usually specify the output power available as a function of signal input power. With higher pumping levels, the signal output power can be increased, which is why the present value of 15-16 dBm is expected to increase as stronger pumps become available.

### Noise figure

The predominant source of noise in the erbium amplifier is spontaneous emission from the transition between the upper level and the ground state. Along the length of the amplifier, the spontaneous emission will undergo amplification and reabsorption in much the same way as a small signal passing through the amplifier. This explains why the amplified spontaneous emission (ASE) spectrum differs in shape from the fluorescence spectrum, although they encompass the same spectral region.

At the detector, the signal and the ASE are combined in conformance to square-law detection. Hence, sources of noise will not only be the signal and the ASE, but also terms stemming from the beating between the signal and the various components of the ASE, and from the beating between the components. This type of noise is often referred to as “beat” noise.

The noise figure  $F$  or  $N_f$  of an optical amplifier is the measure of the degradation of the signal-to-noise ratio  $S/N$  due to the insertion of the amplifier. It is defined as :

$$N_f = \frac{S / N_{\text{without amplifier}}}{S / N_{\text{with amplifier}}} \quad \text{Formula 12-1}$$

It can be shown that for a high input signal and large gain, the major source of noise is the signal-spontaneous beat term. Then  $N_f = 2n_{sp}$ , where  $n_{sp}$  is the spontaneous emission factor given by:

$$n_{sp} = \frac{N_2}{N_2 - \frac{\sigma_a(\lambda_s)}{\sigma_e(\lambda_s)} \cdot N_1} \quad \text{Formula 12-3}$$

$N_{1,2}$  represent the population of energy levels 1 and 2 respectively, and  $\sigma_a$  and  $\sigma_e$  are the absorption and emission cross-sections of the  $\text{Er}^{3+}$  ions.

From this follows that for a fully inverted amplifier,  $n_{sp} = 1$ , and the  $N_f = 2$ . Ideally, the smallest degradation possible of  $S/N$  is therefore 3 dB. Theoretically, since the noise figure only depends on the degree of population inversion, quantum-limited noise operation can be achieved using any of the possible pump bands. The  ${}^4\text{I}_{13/2}$  band deviates slightly from this statement due to the non-negligible emission cross section at the pump wavelength,  $\sigma_e(\lambda_p)$ , causing the population inversion to be incomplete.

This also explains why the noise figure increases when part of the fiber is not fully inverted: for example, when the pump power is too low with respect to the fiber length so that, at the end of the fiber, the ions are not inverted. Counter-directional pumping gives a worse noise figure than co-directional pumping, since it is especially important to attain a good inversion where the signal is low.

It can also be shown that, for a given input signal, there is an optimum *length of fiber/pump power* – pair for which the noise figure is minimum. Increasing the length of the fiber, and the pump power, will result in increased ASE in the backward direction, causing an increase in gain saturation at the front end of the fiber where the signal is low and, hence, a degradation of the signal-to-noise ratio.

## Fabrication of erbium-doped fiber

Fabrication techniques have long since reached a point where consistent high-quality, commercial fiber can be produced in large volumes. The addition of rare-earth elements does not alter the glass in such a way that any significant modifications are needed, and today all of the major silica-based fiber-making technologies have reported erbium-doped fiber. This section serves as an introduction to some of the most important methods used.

### Fabrication methods

Many of the techniques for doping rare-earth ions into fibers are generic and can, in principle, be used with any rare-earth ion as well as many other elements of the periodic table; for example, transition metals. The methods described here are well established for erbium and its most common co-dopants, such as aluminum. However, other dopants might impose additional restrictions on the choice of method.

### Bulk methods

There are several different ways of making optical fiber out of bulk glass: the rod-in-tube, double-crucible and stratified-melt methods, and various casting techniques. Today they are used mainly because of their great adaptability to different types of glass, which means that they are especially important when multicomponent glass, such as ZBLAN, is processed. They all enable the use of commercially available laser glasses which typically contain several percent of rare-earth ions. Such high loading requires a soft host glass containing a large fraction of network modifiers in order to inhibit crystallization of the rare earth.

In the following, only the rod-in-tube method will be reviewed. This technique was the basis of all pioneering work on multicomponent glasses. It is one of the oldest ways of making a preform and also one of the simplest ways of fabricating rare earth doped fiber.

Rod-in-tube manufacturing starts out with a core rod of rare earth doped glass and a cladding tube, each formed independently. The rod is placed within the tube, and the glasses are heated to softening. The tube is then collapsed onto the rod, and the resulting preform is drawn to fiber, as shown in Figure 12-4.

Drawbacks to this inexpensive technique include formation of irregularities in the core-to-cladding interface, difficulties in maintaining glass purity and lack of control of the refractive index. As a result of these disadvantages, the technique produces medium-loss to high-loss fibers.

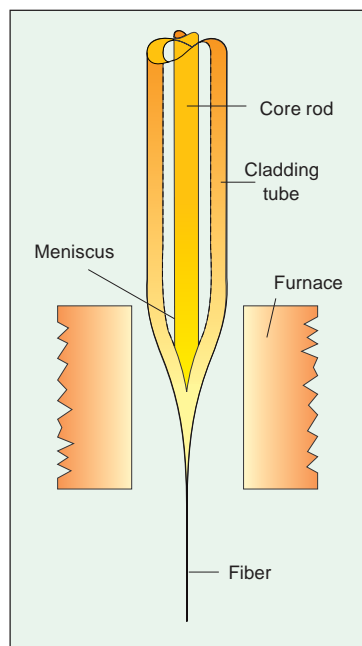

Fig. 12-4 Fiber fabrication by "rod in tube" method.

### Solution doping

The solution doping method, first reported by Stone and Burrus in 1973, does not seem to have been used again until 1987. The process is a slight modification of the regular MCVD process. The different steps can be seen in Figure 12-5 below.

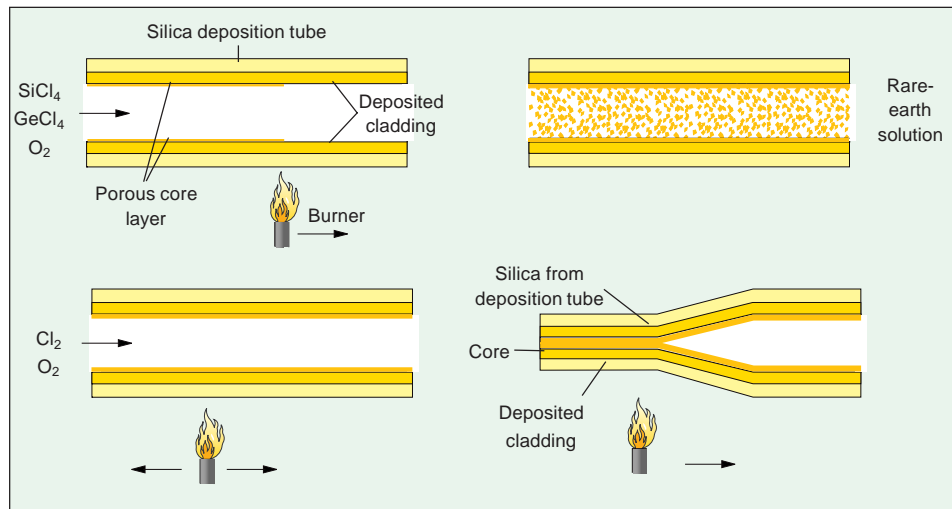

Fig. 12-5 Erbium fiber fabrication by the “solution doping” method,

At first the cladding and the outer, undoped part of the core are deposited inside the substrate tube as usual. When reaching that part of the core which is to be doped, the temperature is lowered to prevent complete fusing of the glass. This produces a white, porous soot sponge inside the tube. The preform is then removed from the lathe. A solution of erbium - and any co-dopants to be incorporated - is introduced into the tube and allowed to soak into the pores for approximately one hour. Various salts in either aqueous or alcoholic solution can be used, including halides, nitrates and sulfates. The dopant concentration is determined by controlling the solution concentration of the dopant. This gives more reproducible results than trying to control the dopant levels by using different diffusion times. The liquid is subsequently expelled from the tube and the porous layer blown dry. This is followed by dehydrating the preform by heating it in an  $\text{O}_2/\text{Cl}_2$  atmosphere for approximately one hour. The porous layer is carefully fused in the  $\text{O}_2/\text{Cl}_2$  atmosphere to create a completely dry material, and the preform is then collapsed in the usual manner.

Slight modifications to the process include the deposition of pure silica core layers and soaking the layer in an  $\text{Al}^{3+}$  rare-earth solution to make an  $\text{Al}_2/\text{SiO}_2$  host glass - a method that has been used to fabricate fibers with as much as 15 wt % rare earth in the core glass. This is a very high concentration level in comparison with normal levels of rare earth doping of at most a few hundreds of ppm.

### Vapor phase doping

Most production methods used in the manufacture of low-loss fibers by vapor-phase deposition can be modified to enable the incorporation of rare-earth ions. These methods are particularly interesting in the case of erbium fiber with a very low concentration level for use in applications where low background loss is important; for example, distributed amplifiers. (This kind of fiber cannot be made

as readily with the solution-doping process, mainly because of contaminants introduced with the salts from which the solution is made.) Drawbacks include greater complexity, the difficulty to achieve homogeneous concentration along the preform axis and inferior reproducibility.

In principle, these methods work by introducing the rare-earth dopant in a vapor-phase form together with the normal reactants in the manufacturing process, letting them react and deposit at the same time. Three different ways of doing this can be seen in Figure 12-6. The method, which was used in the pioneering work by Poole, et al., is shown in the upper part of Figure 12-6. In a first step, the rare-earth chloride is fused to the walls of a dopant carrier chamber, upstream of the deposition tube. The cladding layers are then deposited in the usual way. During the core deposition, the dopant chamber is heated to  $\sim 1000^\circ\text{C}$  to increase the vapor pressure of the halide. The vapor is incorporated with the main reactants and included with the deposited core layers. The tube is then collapsed and drawn in the usual way.

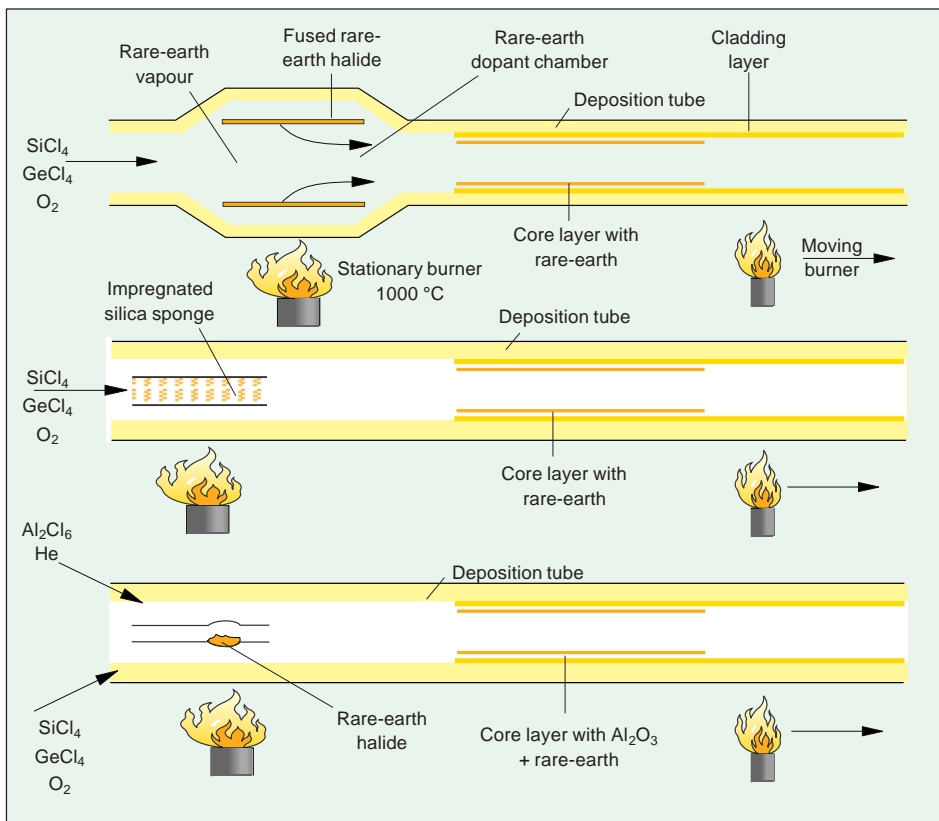

Fig. 12-6 Various forms of the “volatile halide” method.

The other two methods are modifications on the same theme. As shown in the middle part of Figure 12-6 a silica sponge impregnated with a rare earth is used in place of the dopant carrier chamber. This provides a more reproducible rare-earth vapor stream. Finally, the lower part of the figure shows how  $\text{Al}_2\text{O}_3$  can be incorporated in the core host glass by transporting  $\text{Al}_2\text{Cl}_6$  in heated lines to the reaction zone



## Erbium fiber design

### Geometrical design considerations

Small amounts of rare-earth ions do not modify the refractive index of the fibers. This means that there is no need to alter basic design and production techniques. However, other factors that may have a great impact on amplifier performance must be considered.

Since erbium in silica glass is a three-level system, pumping must be effective in order to overcome the reabsorption from the ground state level. An insufficient overlap between the pump light profile and the erbium concentration profile will result in poor population inversion and, thus, reduced amplifier performance.

This is what occurs when an ordinary singlemode fiber has its entire core doped with erbium, as in Figure 12-7 (left). Here, the insufficient pump field intensity in the outer part of the core results in an uninverted erbium ion population, causing absorption rather than amplification of the signal.

To improve the situation, the fiber can be optimized in two ways. First, the numerical aperture (NA) of the fiber can be increased, which will result in greater mode field compression, Figure 12-7 (middle). This is done by increasing the germanium concentration in the core while at the same time decreasing the core diameter. The effect is improved overlap between the mode field of the pump light and the erbium concentration profile, and improvement of their overlap with the mode field of the signal. The high NA will also result in lower bend losses. This is advantageous when the fiber is to be coiled; in an amplifier module, for example. It should also be observed that the smaller core diameters lead to mismatch in mode field diameters when erbium-doped fiber is spliced to standard singlemode fiber. (A normal mode field diameter in a state-of-the-art erbium fiber is approximately 5-6  $\mu\text{m}$ .) This problem can be solved by tapering the splice.

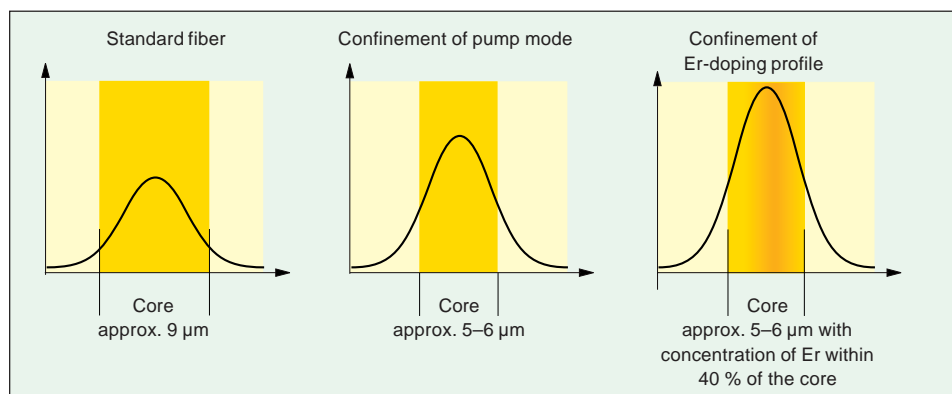

Fig. 12-7 Design optimization of erbium doped fiber

The next step in optimizing the design is to concentrate the erbium ions to the central part of the core where the pump intensity is highest, as shown in Figure 12-7 (right). In this way, incomplete population inversion in the outer ends of the core can be avoided, but there is a limit to how high the concentration of erbium may be and still give desirable results. As it turns out, the concentration of the erbium ions should be approximately 40 % of the core. In higher concentrations, parasitic effects due to ion-ion interaction between the erbium ions will come into play and have a negative effect on amplifier efficiency.

### Choice of host material in the fiber

Fibers can be made out of plastics, liquids and glasses, all of which can be doped, but glasses are the most suitable materials for telecommunications since they offer a low-loss transmission medium that can readily be made in long lengths. Today's commercial telecommunications fiber is almost exclusively made of silica glass, which makes it desirable to use material of similar composition when manufacturing active fibers. In addition to providing low background losses this will also result in good compatibility with standard fiber - an important consideration in fusion splicing.

To optimize the active fiber for amplifier use there are, however, a few modifications that can be beneficial. The host glass composition has significant impact on the solubility of the rare-earth dopant. This in turn affects the fluorescence lifetime and the fluorescence line shape, two parameters that are crucial to good amplifier performance.

By adding aluminum or phosphorous to the fiber core glass, the solubility of erbium ions will increase significantly. As can be seen in Figure 12-8, this has important effects not only on the erbium ion concentration but also on the fluorescence properties.

A few things should be observed in the picture. The dashed line in Figure 12-8 shows that  $\text{Ge}_2\text{O}_3$  co-doped fibers have double peaks. This is not desirable since it will put sharp restrictions on the signal wavelength specification in the single-channel case and result in different gain values for different channels in WDM applications. The dotted curve shows that  $\text{P}_2\text{O}_5$  is a good candidate as a co-dopant but that the broadest fluorescence line width, resulting in the broadest gain curve, is obtained with  $\text{Al}_2\text{O}_3$ . (Note also how the gain peak shifts by up to 5 nm when the host material is changed.) Aluminum is the most popular co-dopant and a standard choice for erbium-doped fiber.

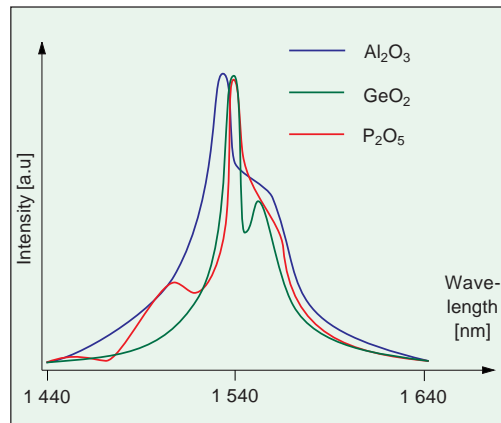

Fig. 12-8 Effect of co-dopant composition on fluorescence spectrum.

Another important reason for this choice is the effect that the adding of aluminum to the core glass will have on the erbium concentration profile. When the vapor-phase method is used in the manufacture of VAD fibers, the rare earth is incorporated uniformly across the core resulting in a step profile. When manufacturing fiber by the MCVD method, this is not the case. In  $\text{GeO}_2\text{-SiO}_2$  host fibers, the formation of a volatile suboxide of  $\text{GeO}_2$  during the collapse stage will result in a central refractive index depression, sometimes known as burn-off. As it turns out, the rare-earth ions are also swept out at this stage. The rare-earth concentration profile will therefore closely resemble the refractive index profile, exactly the opposite of what is required for optimum amplifier performance. This can be seen in Figure 12-9.

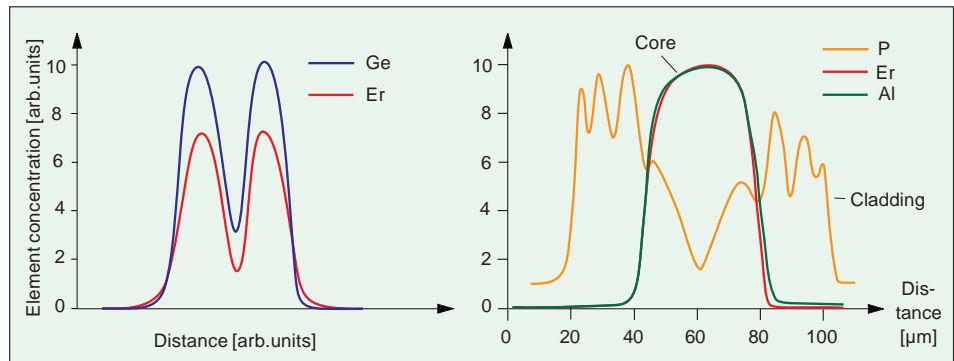

Fig. 12-9 Effect of co-dopant composition on erbium concentration profile.

Although some compensation can be achieved by etching the innermost part of the core, concentrating the rare earth to the center region of the core would be difficult with the MCVD method. The problem is resolved by using  $\text{Al}_2\text{O}_3$  as a co-dopant in the core material. Because of the involatility of the  $\text{Al}_2\text{O}_3$ , and the lack of formation of a volatile suboxide, it will not suffer a burn-off but remain in the center of the core. Since the erbium ions tend to cohere with the aluminum ions, the effect on the erbium concentration profile is that of mirroring the aluminum step profile. This will give the desired profile for the erbium concentration.

## Various amplifier designs

### Single-wavelength systems

The EDFA can be incorporated primarily at three different locations in a typical point-to-point-system, and its design is adapted accordingly:

- as power amplifier at the head-end
- as in-line amplifier
- as pre-amplifier at the receiver-end

### Power amplifier

The characteristic of a power amplifier is to allow high output power. To achieve this, a dual-pumping scheme is often used, in which case the erbium fiber is also pumped in the counter-propagating direction. The fiber operates in a highly saturated regime, since the signal input is typically of the order of  $-5 - 0$  dBm.

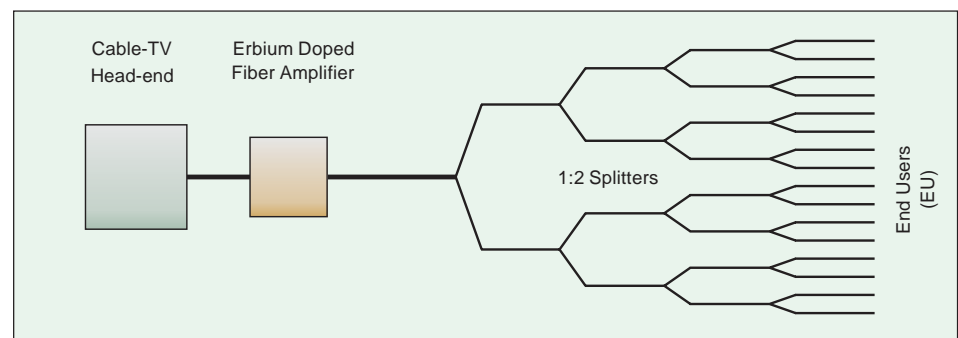

Fig. 12-10 The EDFA as power amplifier in a optical fiber CATV network.

### In-line amplifier

Optical amplifiers can directly replace opto-electronic repeaters in systems where regeneration of the signal is not required for reasons of dispersion. There is no definite design of the ideal in-line amplifier, since the overall system to be considered determines some of the characteristics. Summarily it can be foreseen that, in medium-haul links, high-gain amplifiers operating in the small-signal gain regime and spaced 50 km apart will be appropriate, whereas in long-haul links, fiber non-linearities call for narrower spacing and lower gain. An example is the 5 Gb/s TAT 12 transatlantic system deployed in 1995, where there are some 250 EDFAs concatenated along the line. The amplification provided by each amplifier is kept low (around 10 dB) in order to prevent noise from building up. Hence, the spacing between the amplifiers - 33 km - will be shorter than in less extreme systems. The input levels is therefore relatively high and the amplifiers will operate in saturation. As a by-product, this way of operating the amplifier automatically serves as a gain equalizer. Narrowband-passband filters will also be inserted along the line so as to eliminate the build-up of ASE.

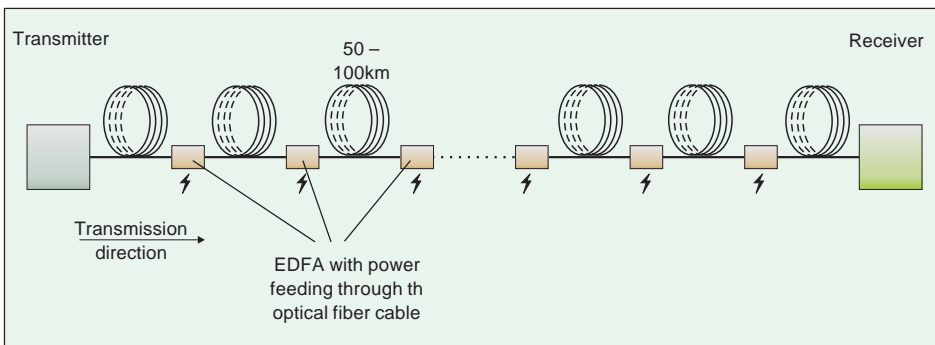

Fig. 12-11 An in-line system where each EDFA is power fed through power cables within the optical fiber cable

### In-line amplifier without power feeding

A different approach is used in long-haul systems using an optical fiber cable without the capability of power feeding. The advantage of such a system is that the cable will be much simpler in its design. The system to be described is used in a submarine installation.

The distance to cover is longer than what is possible with only an amplifier at the transmission side.

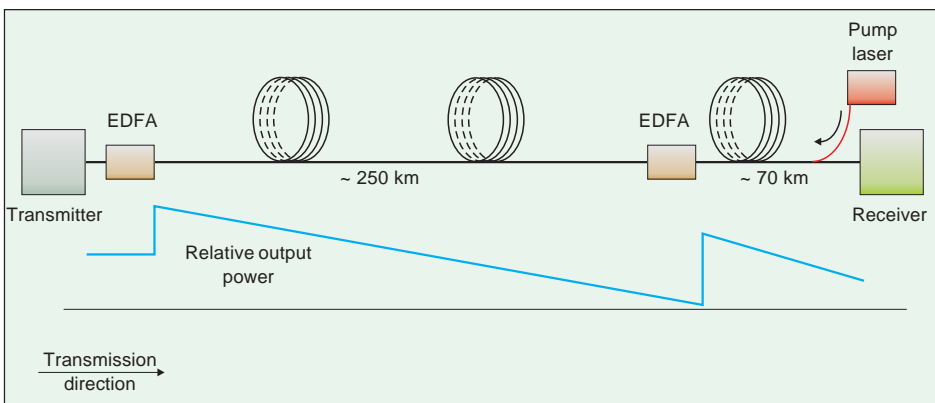

Fig. 12-12 In-line amplification without mid-span power feeding of the amplifier

The signal is amplified with an EDFA at the transmitter side. At a distance of 250 km a splice-box containing some 30 m erbium doped fiber. One erbium doped fiber per each transmitting fiber in the cable. At the receiving end, 70 km further away, the pump lasers are placed, transmitting energy at 1490 nm wavelength. The energy will exit the erbium fiber that will transfer the energy to the transmitted signal on 1550 nm. In this way more than 320 km transmission distance can be covered. This type of systems will also be used for wave-length multiplexed systems.

### **Pre-amplifier**

In this application, too, the amplifier is operated in its small-signal regime. The prime concern is the noise figure, and the choice of pump wavelength is therefore likely to be 980 rather than 1480 nm, assuming that the reliability of the pump sources is the same. Furthermore, since ASE is one of the main noise sources, a suitable narrowband, low-loss optical filter is inserted after the EDFA.

### **Multi-wavelength systems**

The cases cited above are also true of multi-wavelength systems. Extra care has to be taken in the design of filters and of the erbium-doped fiber in order to achieve equivalent gain throughout the bandwidth. This is especially crucial in the concatenated case, where a slight gain difference between channels (0.5 dB) in one amplifier can build up and become non-negligible after several amplifiers. This is a problem currently under investigation, and some gain-equalization schemes have been presented see further in chapter 13.

### **Analog vs. digital systems**

In analog systems, for instance in analog CATV, the amplifier has components with stricter specifications as regards reflection and linearity. Otherwise, harmonic distortion and intermodulation products caused by the amplifier may impair system capacity. This is not a problem in digital systems.

## **Applications and Outlook**

As suggested in the introduction, the fiber amplifier is now having a major impact on our local and global optical communication systems. Not only will the capacity and span of the present systems be dramatically increased, but the amplifier also offers exciting possibilities for all-optical distribution schemes.

### **Capability explosion**

The increase in capability brought about by the EDFA and wave-length multiplexing systems are perhaps best illustrated by the following graph displaying the evolution of the bit-rate distance product (in  $\text{Gb/s}^{-1} \times \text{km}$ ) with time, and the impact of each novel technology, see Figure 12-13.

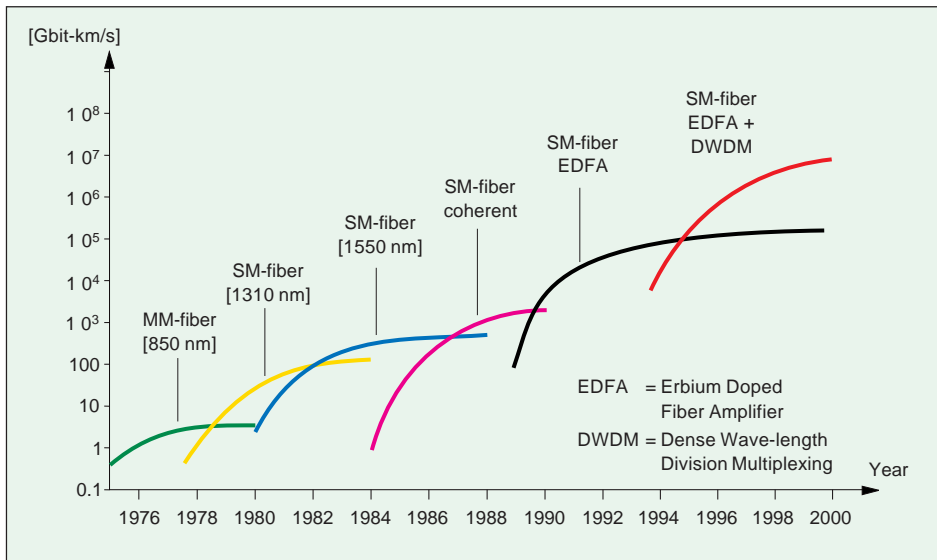

Fig.12-13 Six generations of fiber optic transmission technology.

Figure 12-13 shows how the introduction and exploitation of the EDFA and DWDM has caused the capability to soar in the past years, increasing by orders of magnitude.

## Transmission networks

The first dramatic demonstration of ultra-long, large-bandwidth optical communications using amplifiers was in 1989, when Edagawa of KDD demonstrated a 1.2 Gbit/s system over 904 km with 12 cascaded EDFAs, giving a total optical gain of 203 dB. This pioneering demonstration paved the way for numerous “hero experiments” with ever longer distances and higher bit rates. Essentially, the dream of a limitless transmission line has now been realized with the recent demonstration of the transfer of NRZ data and soliton pulses in dispersion-shifted fiber over distances exceeding 15 000 km at 5 Gb/s. When it came to true implementation, submarine links was the first to include the EDFA. There are uncountable applications. Here are just a few.

First, the spectacular transoceanic links that are crossing the Pacific (TPC5, 6,...) and the Atlantic (TAT 12/13, ..) Oceans - see section “In-line amplifier”.

Second, as mentioned previously, repeaterless links connecting islands to each other and/or to the mainland. Projects like: Cyprus-Israel (261 km) and Finland-Sweden (260 km) are two examples. A booster amplifier after the transmitter and a preamplifier near the receiver allow a loss budget great enough to compensate for the losses in the link. The advantages over classic systems are obvious: no need for a costly submarine repeater, no need for power supply lines to feed the electronics, no need for supervisory channels; all active elements are on land and easily accessible, and system upgrades need only involve the transmitter and the receiver, not the amplifiers.

Third, connecting oil-rigs to mainland, like in Norway where platforms are linkt to the west-coast of Norway thus all production controll will be performed by personell stationed on land instead of off-shore.

This type of link will surely be advantageous in terrestrial applications as well, whether in harsh climates or as trunk links between major cities. As the traffic grows, system capacity can be expanded without the need for any embedded electronics which would otherwise be a bottleneck. The possibility of changing to dense WDM (where  $\Delta\nu = 40\text{--}80$  GHz) is yet another appealing option.

### Distributed networks

The design of distributed fiber systems is largely enabled by the EDFA, since it can provide a high initial level of signal power at the node, which can then be distributed into a large number of separate lines by passive fiber power splitters. Here, as with the power amplifier, the desired feature is the high output power. In fact, an output power as high as 24 dBm (251 mW) has been demonstrated by means of EYDFAs, i.e. fibers co-doped with ytterbium and pumped with a diode-pumped YAG laser. A simple calculation shows that for each 3 dB of gain, the number of terminals can be doubled. Assuming that an installed system can provide 100-200 terminals with a detectable signal up to 10 km from the head-end, and that the booster amplifier is capable of providing an extra 21 ( $21=3\times 7$ ) dB of gain, the number of terminals can be multiplied by  $2^7 = 128$ . Over 39 million potential customer-size networks fed from a single head-end have been demonstrated, requiring about one amplifier per 10 000 customers. For the immediate stages of implementation, more modest discrete amplifiers located at strategic power-splitting points may be sufficient.

So, in conclusion, the advantages brought about by the introduction of fiber amplifiers into the distributive network are manifold. Placing a power booster at or near the head-end and passive splitters at the nodes means that the cost will be apportioned among a larger number of subscribers. The amplifier, being bit-rate and format independent, would allow future upgrades and expansions. It will also be possible to have overlays of broadband services where such services are requested.

### Other areas of application

Since gain in a rare-earth doped fiber amplifier is distributed along the entire length of the active fiber, a decrease in dopant concentration can be compensated for by an increase in length. Utilizing this idea, by making sparsely doped fiber, the entire transmission link can be used as an amplifier, pumped from one or both ends. This is what is referred to as a distributed amplifier. The dopant ion concentration can be tailored to just overcome the background loss, giving a long-distance, lossless transmission link at certain wavelengths. Soliton transmission systems and BUS distribution network architectures, where background and tapping losses are compensated for, are two applications where distributed amplifiers can become potentially significant.

Another interesting area of application for active fiber technology is in fiber lasers, where the fiber is used as the amplifying medium in the laser cavity. Clearly, fiber lasers offer the following key features:

- a wide range of operating wavelengths
- broad tunability
- high quantum efficiency and high output powers
- transition opportunities at novel wavelengths

Fiber lasers can be expected to have a significant impact on areas that make use of these features. This will be in applications such as short-wavelength lasers for information processing, long-wavelength lasers for spectroscopical applications and laser surgery or as fiber laser sources for very short pulses, the latter being the most important for telecommunications purposes. If the 35 nm bandwidth in the 1.54  $\mu\text{m}$  region of an EDFA is transformed into the time domain it will enable the generation of picosecond pulses. Such pulses have been generated, and fiber lasers could become a potential low-cost practical soliton source in the future.

Fiber amplifiers have also been used to improve the dynamics of 1.5  $\mu\text{m}$  OTDRs. Here, an amplifier is used to amplify both the outgoing and incoming pulses, thereby improving dynamics by more than 10 dB. It seems probable that fiber amplifiers will be used to enhance other types of measurement in the 1.5  $\mu\text{m}$  wavelength range. This area of application has not yet been fully investigated.



Fig. 12-14 EDFA with a size comparing box of matches.

Finally, the potential of active fibers to be used as fiber optical sensors or to enhance optical sensor networks has been pointed out in the literature, but has not been fully exploited by the fiber sensor community. One of the first rare-earth doped fiber sensors to be reported made use of the spectral shift in the ionic absorption with local surrounding temperature at a fixed wavelength. Changes in the backscattered signature from the fiber were used to identify the location and amount of change in temperature along the fiber. However, this device did not make use of the active properties of the doped fiber as a sensing mechanism. In the future there might be optical sensing capabilities in exploiting the distributed gain available in an amplifying fiber. Any element that changes its absorption or reflectivity in the presence of an external stimulus could be used to modify the signal output from an oscillator with the sensing element in, or as part of, the cavity.



# Chapter 13

## Tables

### Physical properties

#### Recommended consistent values of the fundamental physical constants

Atomic mass unit [1u] .....	$1.6603 \times 10^{-27}$ kg
Velocity of light in vacuum [c] .....	$2.997925 \times 10^8$ m/s
Gravitational acceleration, mean value [g] .....	9.80665 m/s
Boltzmann constant [ $k = R/N_A$ ] .....	$1.38054 \times 10^{-23}$ J/K
Elementary charge [e] .....	$1.60210 \times 10^{-19}$ C
Planck's constant [h] .....	$6.6256 \times 10^{-34}$ Js
Rydberg constant [ $R_\infty$ ] .....	$1.0973711 \times 10^7$ m <sup>-1</sup>
Rydberg constant for hydrogen [ $R_H$ ] .....	$1.0967758 \times 10^7$ m <sup>-1</sup>
Electron volt [1 eV] .....	$1.60210 \times 10^{-19}$ J

#### Young's modulus for some common materials used in cable manufacturing [N/mm<sup>2</sup>]

Steel (spring) .....	200 000
Glass (optical fiber) .....	72 500
Aramide yarn .....	100 000
Polyamide PA .....	1 700
PBTP .....	1 600
High Density PE (HDPE) .....	1 000
Medium Density PE (MDPE) .....	400 - 700
Low Density PE (LDPE) .....	200 - 300
PVC (soft) .....	60

#### Thermal expansion coefficient for some common materials used in cable manufacturing [1/K]

Steel (spring) .....	$1.3 \times 10^{-5}$
Glass (optical fiber) .....	$5.5 \times 10^{-7}$
Aramide yarn .....	$-2 \times 10^{-6}$
Polyamide PA .....	$5.8 \times 10^{-5}$
PBTP .....	$1.5 \times 10^{-4}$
High Density PE (HDPE) .....	1 - $2.5 \times 10^{-4}$
Medium Density PE (MDPE) .....	1 - $2.5 \times 10^{-4}$
Low Density PE (LDPE) .....	1 - $2.5 \times 10^{-4}$
PVC (soft) .....	$1.5 \times 10^{-4}$

## Physical properties, cont.

### Silica, pure SiO<sub>2</sub>

Density (at 25°C) .....	2.20 g/cm <sup>3</sup>
Maximum usable operating temperature (continuous) .....	900°C
Heat conductivity (100°C) .....	0.177 cal/g °C
Change in refractive index with temperature (0 - 700°C) .....	$1.28 \times 10^{-5} / ^\circ\text{C}$
Thermal expansion coefficient .....	$5.5 \times 10^{-7} / ^\circ\text{C}$
Refractive index at 1300 nm .....	1.44692
Refractive index at 1400 nm .....	1.44578
Refractive index at 1500 nm .....	1.44462
Refractive index at 1550 nm .....	1.44402

### Refractive index (20°C)

Water .....	1.33299
Ethanol C <sub>2</sub> H <sub>5</sub> OH .....	1.36048
Glass (common) .....	1.45886
Diamond .....	2.41730
Gallium arsenide [GaAs] .....	3.56
Gallium phosphide [GaP] .....	3.31
Gallium indium arsenide phosphide [GaInAsP] (1300 nm) .....	3.21 - 3.52
Gallium indium arsenide phosphide [GaInAsP] (1550 nm) .....	3.17 - 3.55
Aluminium gallium arsenide [AlGaAs] .....	2.8 - 4.2

### Refractive index for aluminium gallium arsenide [AlGaAs]

The refractive index for compounds used in laser diodes, LEDs or photodiodes is dependent not only on operating wavelength but also on the mixture relation of the compounds and on the photon energy.

In the diagram to the right, the refractive index is drawn for Al<sub>x</sub>Ga<sub>1-x</sub>As

[If x = 0 = pure GaAs (gallium arsenide) and if x = 1 = pure AlAs (aluminium arsenide)].

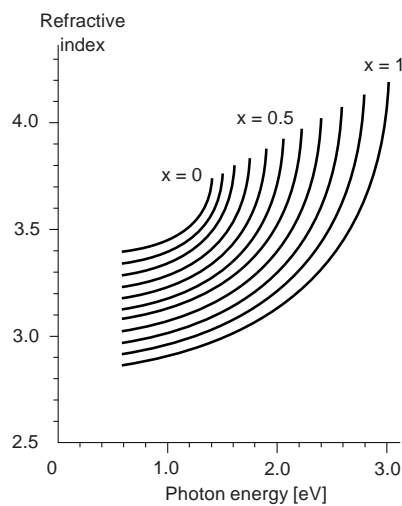

### Power versus decibel

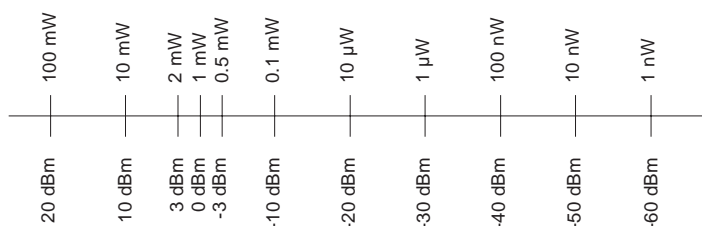

## Structure of the letter code

Example

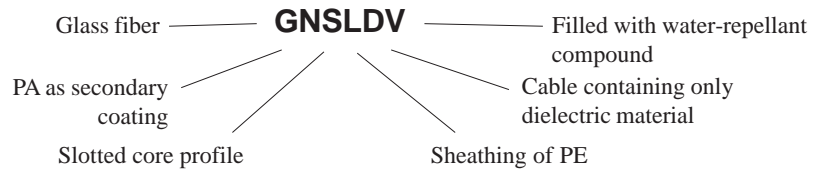

Letter	First letter Conductor	Second letter Insulation or secondary coating	Third letter Sheath or characteristic feature	Fourth letter Characteristic feature or application	Fifth letter Characteristic feature or application	Sixth letter Characteristic feature or application
A	Aluminium without surface coating	Acrylate	Screen of aluminium tape			
B	Aluminium alloy		Lead sheath	Connecting wire	Flame-retardant, halogen-free	
C	Bronze	Foam skin		Cable with suspension strand		
D	Glass/Plastic fiber		Cable containing only dielectric material			
E	Copper, solid		Individually screened cores of units	Nominal capacitance level less than 46 nF/km		
F	Copper, stranded		Braided metallic screen or metallic reinforcement			
G	Glass/Glass fiber	Thermoplastic polyester elastomer	Non-metallic reinforcement			
H	Fiber bundle		Coated fibers, stranded around a strength member			
I		Thermoplastic polyurethane elastomer				
J	Copper clad steel wire	Fiber without secondary coating	Steel tape armoring			
K	Coaxial pair	Polyvinyl-chloride (PVC)				
L	Conductive plastic	Polyethylene (PE)				
M	Copper, flexible	Polypropylene	Metal sheath			
N		Polyamide (PA)				
O		Thermoplastic elastomer				
P	Plastic/Plastic fiber	Paper, unimpregnated	Galvanized steel tape armoring			
R	Copper, extra flexible	Polyester		Signalling cable		
S	Copper, fine strands	Slotted core		Self-supporting cable		
T	Copper, extra fine strands (<0.1 mm)	Fluorethene plastic	Galvanized steel wire armoring			
U		Cellular polyethylene	Without sheath			
V		Rubber	Rubber		Water-repellent compound (jelly)	
W			Corrugated metal sheath or corrugated steel tape armoring			
X		Polyethylene cross-linked	Oval cross section	Cable without requirement of weather resistance		
Y				Cable with requirement of weather resistance		
Z	Tinsel conductor		Screened with copper stripes			

V can be used after the sixth letter if the code for water blocking cannot be defined within a six-letter code.

D can be used after the sixth letter if the code for dielectric material cannot be defined within a six-letter code.

### Example:

GNSLDV is an optical fiber cable, secondary coated with PA, slotted core, PE sheath, non-metallic and filled with water repellent compound

GASLBDV is an optical fiber cable, ribbonized fiber with acrylate, slotted core, PE sheath, halogen-free, flame retardant, non-metallic and filled with water repellent compound

## Load performance for some aerial cable

### Comments:

- 1 This table does not cover the case of combined wind and ice loads; this has to be calculated separately.
2. If installation is done with larger initial sag ( $> 2\%$ ), the tensile forces will be lower.
3. If installation is done with shorter span widths, the tensile forces will be lower.
4. Normally there should not be any problem with "galloping" in this type of installation. Such loads are not covered by these tables.

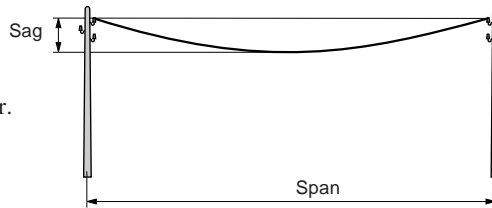

### GRSLCV, 75 m span width

Load case	Sag [m]	Tensile force [k/N]	Cable tension [%]	Comments
Initial	1.5	1.5	0.05	Sag = 2% of span width
25 m/s wind	2.6	7.5	0.27	Storm
20 N/m ice load	2.5	6.7	0.24	Swedish standard
35 m/s wind	3.2	12.0	0.42	Max allowed wind
50 N/m ice load	3.2	12.0	0.42	Max allowed ice load

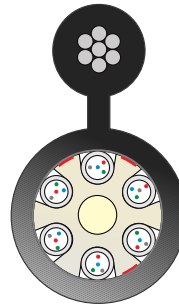

### GRHLCV, 75 m span

Load case	Sag [m]	Tensile force [k/N]	Cable tension [%]	Comments
Initial	1.5	1.3	0.05	Sag = 2% of span width
25 m/s wind	2.6	7.4	0.25	Storm
20 N/m ice load	2.5	6.5	0.23	Swedish standard
28 m/s wind	2.8	8.5	0.30	Max allowed wind
30 N/m ice load	2.8	8.5	0.30	Max allowed ice load

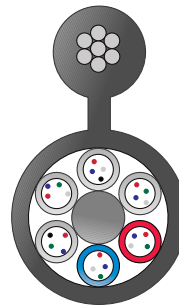

### GASLCV, 75 m span

Load case	Sag [m]	Tensile force [k/N]	Cable tension [%]	Comments
Initial	1.5	1.3	0.05	Sag = 2% of span width
25 m/s wind	2.6	7.4	0.25	Storm
20 N/m ice load	2.5	6.5	0.23	Swedish standard
30 m/s wind	2.8	9.3	0.33	Max allowed wind
35 N/m ice load	2.8	9.3	0.33	Max allowed ice load

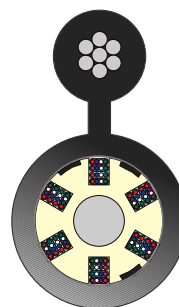

## Load performance of aerial cable cont.

### GRLSLDV, 100 m span (7 kN)

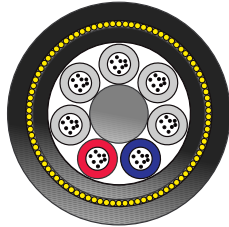

Load case	Sag [m]	Tensile force [kN]	Cable tension [%]	Comments
Initial	2.0	0.9	0.07	Sag = 2% of span width
25 m/s wind	3.1	2.6	0.22	Storm
20 N/m ice load	4.5	6.1	0.51	Swedish standard
51 m/s wind	4.7	6.9	0.57	Max allowed wind
25 N/m ice load	4.8	7.0	0.58	Max allowed ice load

### GRLSLDV, 150 m span (13 kN)

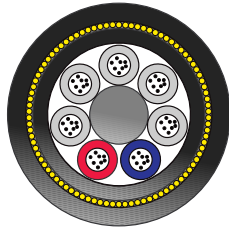

Load case	Sag [m]	Tensile force [kN]	Cable tension [%]	Comments
Initial	3.0	1.6	0.07	Sag = 2% of span width
25 m/s wind	4.3	4.4	0.18	Storm
20 N/m ice load	6.2	9.9	0.42	Swedish standard
55 m/s wind	7.0	13.0	0.55	Max allowed wind
30 N/m ice load	7.0	13.0	0.55	Max allowed ice load

### GRLSDV, 75 m span (4 kN)

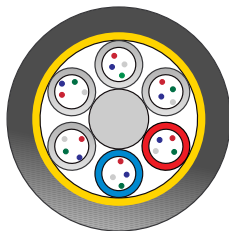

Load case	Sag [m]	Tensile force [kN]	Cable tension [%]	Comments
Initial	1.5	0.5	0.06	Sag = 2% of span width
25 m/s wind	2.3	1.6	0.19	Storm
48 m/s wind	3.4	4.0	0.49	Max allowed wind
18 N/m ice load	3.4	4.0	0.42	Max allowed ice load

## Technical specifications, cable construction

### Slotted core profile, loose tube

#### Color coding of the fibers (each tube)

Fiber 1	Red
Fiber 2	Blue
Fiber 3	White
Fiber 4	Green
Fiber 5	Yellow
Fiber 6	Grey
Fiber 7	Brown
Fiber 8	Black

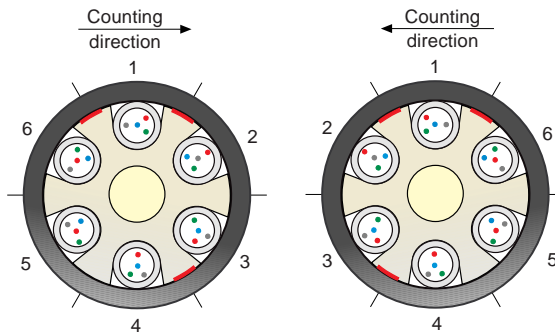

Cables with low fiber counts are manufactured with some slots without fibers. All slots are filled with compound for longitudinal water blocking.

### Slotted core profile, 4-fiber ribbon

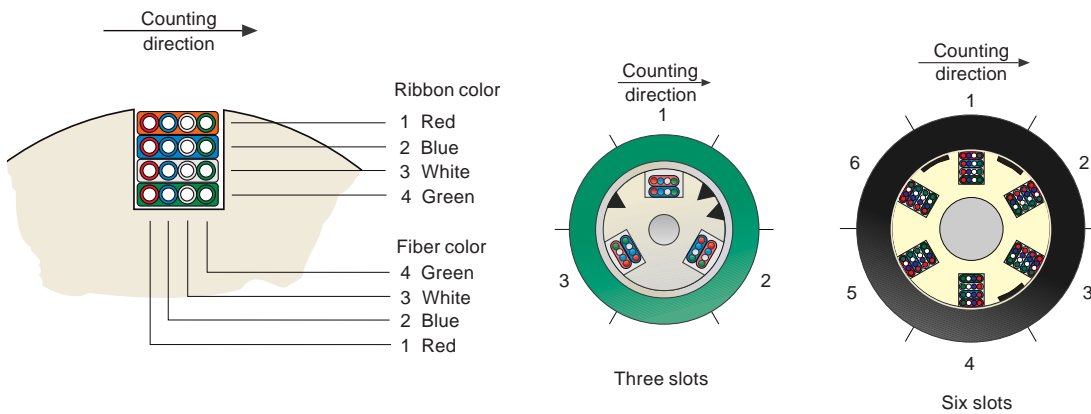

Cables with 4–48 fibers are normally manufactured with shallower slots with maximum 2 ribbons in each slot. The ribbons are color-coded red and blue.

Cables with 52–96 fibers are manufactured according to the figures above.

### Slotted core profile, 8-fiber ribbon

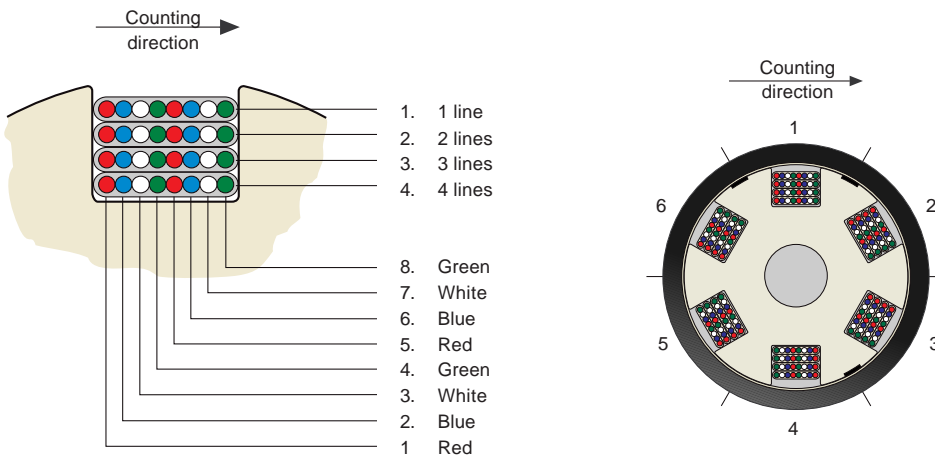

**Note:** Color codes are Ericsson Cable standards, other color codes on request!

## Technical specifications, cable construction

### Concentric profile, loose tube

#### Color coding of the fibers (each tube)

Fiber 1	Red
Fiber 2	Blue
Fiber 3	White
Fiber 4	Green
Fiber 5	Yellow
Fiber 6	Grey
Fiber 7	Brown
Fiber 8	Black
Fiber 9	Orange
Fiber 10	Violet
Fiber 11	Pink
Fiber 12	Turquoise

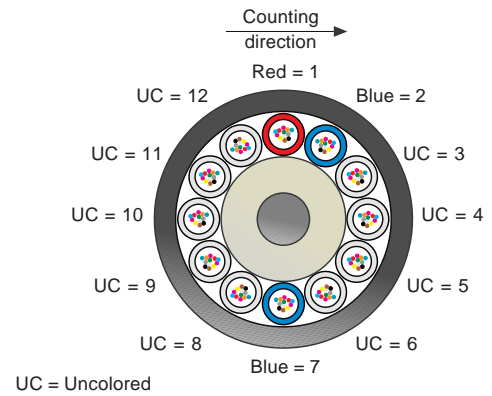

### Concentric profile, tight buffer

#### Color coding of the fibers (each layer)

Fiber 1	Red
Fiber 2	Blue
Fiber 3	White
Fiber 4	White
Fiber 5	White
Fiber 6	White
Fiber 7	Blue
Fiber 8–12	White

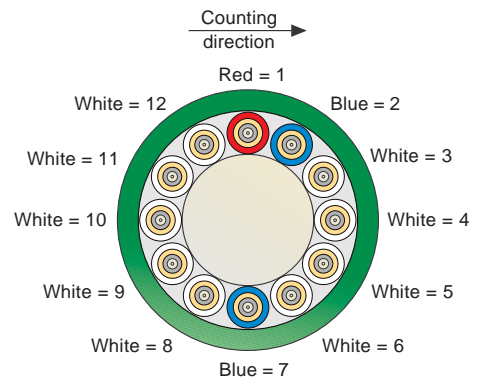

### Cable with tight buffered fibers in slotted core

In cables with up to 12 fibers the fibers are normally coded (each slot):

Fiber 1	Red
Fiber 2	Blue

In cables containing 13–24 fibers the fibers are normally coded (each slot):

Fiber 1	Red
Fiber 2	Blue
Fiber 3	White
Fiber 4	Green

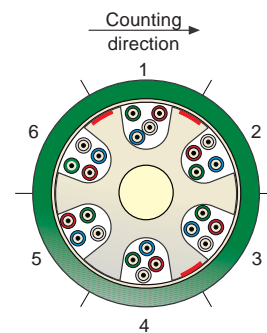

**Note:** Color codes are Ericsson Cable standards, other color codes on request!

## Technical specifications, fiber

### Standard non-shifted single-mode fiber

---

Transmission	Unit	Typical values*
Attenuation at 1 285–1 330 nm .....	dB/km .....	0.36 max
Attenuation at 1 310 nm .....	dB/km .....	0.33 max
Attenuation at 1 530–1 570 nm .....	dB/km .....	0.25 max
Attenuation at 1 550 nm .....	dB/km .....	0.20 max
Attenuation at 1 625 nm .....	dB/km .....	0.22 max
Max chromatic dispersion at 1 550 nm .....	ps/nm×km .....	18
Zero dispersion wavelength range .....	nm .....	1 302–1 322
Zero dispersion slope .....	ps/nm <sup>2</sup> ×km .....	0.092 max
Cut-off wavelength range .....	nm .....	1 150–1 330
Cable cut-off wavelength .....	nm .....	1 260 max
Mode field diameter range at 1 310 nm .....	μm .....	8.8–9.6
PMD .....	ps / $\sqrt{\text{km}}$ .....	0.2 max
<b>Geometry</b>		
Cladding, diameter .....	μm .....	125 ± 1
Cladding, non-circularity .....	% .....	2 max
Primary coating, diameter .....	μm .....	245 ± 5
Mode field concentricity error .....	μm .....	0.5 max
Curl .....	m .....	> 4

#### Mechanical

Proof test: Min 1.0 % strain

\*other values available on request

### Non-zero dispersion shifted single-mode fiber

---

Transmission	Unit	Typical values*
Attenuation window 1525–1 575 nm .....	dB/km .....	0.25 max
Maximum chromatic dispersion over the range 1 530–1 560 .....	ps/nm×km .....	3.5
Zero dispersion wavelength .....	nm .....	≥1 530
Zero dispersion slope .....	ps/nm <sup>2</sup> ×km .....	0.08 max
Polarization mode dispersion .....	ps / $\sqrt{\text{km}}$ .....	0.2 max
Cable cut-off wavelength .....	nm .....	1 360 max
Mode field diameter range at 1 550 nm .....	μm .....	9.2–10.0

\*other values on request

## References

---

- ITU Rec G 650:** Definition of test methods for the relevant parameters of single-mode fiber cables.
- ITU Rec G 651:** Characteristics of a 50/125 μm multimode graded index optical fiber cable.
- ITU Rec G 652:** Characteristics of a single-mode optical fiber cable.
- ITU Rec G 653:** Characteristics of a dispersion shifted single-mode optical fiber cable.
- ITU Rec G 655:** Characteristics of a non-zero dispersion single-mode optical fiber cable.
- IEC 60793-2:** Optical fibers: Product specifications.



**Technical specifications, fiber cont.****Standard multimode fiber**

Geometry	Unit	<u>50 <math>\mu\text{m}</math></u>	<u>62.5 <math>\mu\text{m}</math></u>
		Typical value*	Typical value*
Core, diameter .....	$\mu\text{m}$ .....	50 $\pm$ 2.5 .....	62.5 $\pm$ 3 .....
Cladding diameter .....	$\mu\text{m}$ .....	125 $\pm$ 2 .....	125 $\pm$ 2 .....
Core, non-circularity .....	% .....	6 max .....	6 max .....
Cladding, non-circularity .....	% .....	1 max .....	2 max .....
Core/cladding, concentricity error .....	$\mu\text{m}$ .....	1.5 max .....	3 max .....
Primary coating, diameter .....	$\mu\text{m}$ .....	245 $\pm$ 5 .....	245 $\pm$ 5 .....

**Mechanical**

Proof test: strain ..... % ..... 1.0 % min ..... 1.0 % min

**Transmission**

Numeric aperture (NA) .....	0.200 $\pm$ 0.015 .....	0.275 $\pm$ 0.015 .....	
Attenuation at 850 nm .....	dB/km .....	2.4 max .....	3.0 max .....
Attenuation at 1 300 nm .....	dB/km .....	0.7 max .....	0.7 max .....
Bandwidth at 850 nm .....	MHz $\times$ km .....	400 min .....	200 min .....
Bandwidth at 1 300 nm .....	MHz $\times$ km .....	1 000 min .....	600 min .....

\*other values on request

**“Gigabit” multimode fiber**

Geometry	Unit	<u>50 <math>\mu\text{m}</math></u>	<u>62.5 <math>\mu\text{m}</math></u>
		Typical value*	Typical value*
Core, diameter .....	$\mu\text{m}$ .....	50 $\pm$ 2.5 .....	62.5 $\pm$ 3 .....
Cladding diameter .....	$\mu\text{m}$ .....	125 $\pm$ 2 .....	125 $\pm$ 2 .....
Core, non-circularity .....	% .....	6 max .....	6 max .....
Cladding, non-circularity .....	% .....	1 max .....	2 max .....
Core/cladding, concentricity error .....	$\mu\text{m}$ .....	1.5 max .....	3 max .....
Primary coating, diameter .....	$\mu\text{m}$ .....	245 $\pm$ 5 .....	245 $\pm$ 5 .....

**Mechanical**

Proof test: strain ..... % ..... 1.0 % min ..... 1.0 % min

**Transmission**

Numeric aperture (NA) .....	0.200 $\pm$ 0.015 .....	0.275 $\pm$ 0.015 .....	
Attenuation at 850 nm .....	dB/km .....	2.4 max .....	3.0 max .....
Attenuation at 1 300 nm .....	dB/km .....	0.7 max .....	0.7 max .....
Transmission distance			
for 1 Gbit/s at 850 nm .....	m .....	750 max .....	300 max .....
for 1 Gbit/s at 1 300 nm .....	m .....	2 000 max .....	1 000 max .....

\*other values on request



## Chapter 14

# Exercises

---

### A look back in time and a vision of the future

1. Give examples of some ways in which light has historically been used to communicate messages.
2. Name two pioneers in the field of optical communication, and briefly describe their discoveries or inventions.
3. Name some of the advantages of fiberoptic technology over traditional copper wire technology.
4. What do you see as the future for fiberoptic technology?

### Basic Optics

1. Draw a diagram of the electromagnetic spectrum.
2. What are the ways in which light can be described?
3. What is the approximate frequency of visible light?
4. What is meant by the “three optical windows” in fiberoptics?
5. Describe the difference between reflection and refraction.
6. What is meant by the refractive index of a material?
7. Light travels from an optically more dense ( $n=1.5$ ) to an optically less dense ( $n=1.4$ ) medium. Describe what happens.
8. At what angle would the phenomenon of total reflection occur for the media described in exercise 7?
9. What is meant by the term “polarized light”?
10. Explain what Tyndall’s light is.
11. Describe the phenomenon called Rayleigh scattering.

## Preform Manufacture and Fiber Drawing

1. What are the most important constituents in the manufacture of glass fiber?
2. How is silicon dioxide purified?
3. How and why is silicon dioxide doped during fiber manufacture?
4. Describe in simple terms the MCVD process.
5. Describe in simple terms the OVD process.
6. Describe in simple terms the VAD process.
7. Give the advantages and disadvantages of each of the three processes.
8. Describe in simple terms how a fiber is drawn.
9. What is the “proof test” and why is it performed?

## Optical Fiber and Fiberoptic Parameters

1. Explain the term index profile.
2. What is meant by:
  - a) Step index fiber?
  - b) Graded index fiber?
3. Give a simple explanation of modes.
4. Calculate the number of modes that propagate in a fiber with step index profile 100/140  $\mu\text{m}$ , if the NA is 0.2 and the wavelength is in the first optical window.
5. A fiber with graded index profile 50/125  $\mu\text{m}$  is used at the same wavelength as in exercise 4, and the NA for the fiber is 0.15. How many modes will propagate through this fiber?
6. At what wavelength would a fiber with the following parameters become a single-mode fiber?  
Core diameter = 9.5  $\mu\text{m}$   
NA = 0.10
7. What is meant by the term “numerical aperture” (NA)?
8. Describe what is meant by “single-mode step index fiber”.
9. Describe what is meant by “multimode graded index fiber”.
10. What is dispersion?
11. What is modal dispersion and how does it affect transmission in a fiberoptic link?
12. What is chromatic dispersion and how does it affect transmission in a fiberoptic link?
13. How is it possible to affect the chromatic dispersion?

## How to choose the right optical fiber cable

1. What are the most important criteria in the manufacture of an optical fiber cable?
2. What are the most important types of optical fiber cable design?
3. What are the three most important types of fiber? Give their names and parameters.
4. When and where is the primary coating applied?
5. What are the most common primary coatings?
6. What are the most common types of buffer?
7. Describe the differences between the different types of buffer.
8. What are the most common areas of application for fibers with the different types of buffer?
9. An optical fiber cable always has a strength member. Why?
10. Which are the most common types of strength member?
11. Draw a simple sketch of a cable without a core, showing its various parts and listing the cable's most important areas of application.
12. Most cable designs include a core. What are the reasons for including a core?
13. Why are the optical fibers guided in a spiral around the core in a cable?
14. Because of the pitch of the spiral, the fibers need to be longer than the actual length of the cable. How much longer would the fiber need to be for a 4 km long cable with a pitch radius of 3.5 mm and a pitch of 150 mm?
15. What would the fiber's bend radius be in the example in exercise 14?
16. What is meant by the term "expansion window"?
17. In an optical fiber cable with a slotted core profile, the pitch is 150 mm. The fiber can creep between  $D_{\max}=9$  mm and  $D_{\min}=7$  mm. Make a simple drawing and calculate the percentage that the cable can elongate or shorten.
18. The optical fiber cable in exercise 17 has polyethylene with a cross sectional area of 80 mm<sup>2</sup>, polyamide with cross sectional area 20 mm<sup>2</sup> and GRP with an area of 10 mm<sup>2</sup>. Calculate the elongation of the cable in percent for a temperature increase of 65°C.
19. Calculate the elongation of the same cable as in exercise 18, except that the GRP is replaced with steel which has a modulus of elasticity (Young's modulus) of 203 GPa.
20. Will the cable in exercise 19 be able to cope with a temperature window of  $\pm 65^{\circ}\text{C}$ ?
21. What is meant by the terms "moisture barrier" and "longitudinally waterproofing"?
22. Why does optical fiber cable have a sheath?

23. What are the most common materials used for the sheath?
24. What are the most common methods of reinforcing optical fiber cable?
25. What are the advantages and disadvantages of the various methods of reinforcing optical fiber cable?

### **Laser and Light Emitting Diodes for Information Systems ?**

1. What are the most common light sources and which of these are used in fiberoptic communication?
2. What are the requirements for a light source for fiberoptic telecommunication?
3. What are the most common elements used in the manufacture of laser diodes and LEDs and where are these found in the periodic table?
4. Name some of the most common areas of application for laser diodes and LEDs.
5. What causes an atom's optical spectrum?
6. Describe the optical spectrum of hydrogen.
7. What is a valence band?
8. What is meant by the term "conduction band"?
9. Explain what the band gap is.
10. Explain what the following are and describe the differences between them in terms of their energy band diagrams:
  - a) Conductors
  - b) Insulators
  - c) Semiconductors
11. What is meant by the expression "the substance is p-doped"?
12. What is meant by the expression "the substance is n-doped"?
13. What does the word LASER stand for? Explain.
14. What happens during absorption?
15. Describe the two processes through which light can be emitted from an atom.
16. What is meant by the term "homojunction laser"?
17. How is light coupled from the laser diode into the fiber?
18. Name some of the advantages and disadvantages of the LED as compared to the laser diode.
19. How does the output power from a laser diode differ from the output power of an LED as the current increases?
20. What is the spectral width in GHz of a laser diode with a spectral width of 0.5 nm at a wavelength of 1310 nm?
21. Draw a simple diagram that shows pulse, intensity and phase modulation.

## Optical Detectors

1. What are the two most common photodetectors used in telecommunication?
2. Explain in simple terms the function of a PN photodiode.
3. Why is the efficiency of a photodiode increased if an intrinsic layer is placed between the p- and n-layers?
4. Explain in simple terms the function of an avalanche photodiode.
5. Which parameters affect the detection of light in a photodiode?
6. How does thermal noise change in relation to the photodiode's bandwidth?
7. Calculate the SNR in dB if the output signal's average level is  $90 \mu\text{W}$  and the noise level is  $40 \text{nW}$ .
8. Explain the term BER.
9. What is meant by "responsivity"?
10. What coupling losses can be expected from the coupling between the fiber and the detector?

## Splicing of Optical Fibers

1. Describe the different methods of splicing optical fibers.
2. What are the requirements for splices and optical cable connectors?
3. The losses in a fiberoptic link result in attenuation of the optical signal. What are the losses that can occur in a fiberoptic link? Explain.
4. Calculate the loss in dB when a  $10/125 \mu\text{m}$  fiber with  $\text{NA} = 0.10$  is spliced to a  $12/125 \mu\text{m}$  fiber with  $\text{NA} = 0.13$ . Calculate the loss for both directions of transmission, and from these values, calculate the average value.
5. Where two  $10/125 \mu\text{m}$  fibers are connected together, the connectors cause a radial misalignment of  $2 \mu\text{m}$ . How great a loss can be expected from this misalignment?
6. The fibers in exercise 5 have an  $\text{NA} = 0.25$ , and the fibers in the connectors do not quite reach each other, leaving a longitudinal separation of  $3 \mu\text{m}$ . Calculate the loss in dB caused by this separation.
7. Explain what is meant by "vertex".
8. How can vertex misalignment arise and what does it result in?
9. Why is it important to cut the fiber accurately at a  $90^\circ$  angle before fusion splicing?
10. Describe the process of splicing fibers in a fusion splicer.
11. Why are the fiber ends pre-fused before the actual splicing process begins?
12. Describe at least three mechanical splices, their appearance and functionality.
13. What are the requirements for an optical fiber cable connector?
14. How does an SMA connector differ from an FC/PC connector?

## The Fiberoptic Link and System Dimensioning

1. You are planning a telecommunications link. Select the transmission media and give reasons for your choice.
2. Give examples of simplex, half-duplex and duplex transmission.
3. Draw the following network structures and give them their topological names.
  - a) Telecommunications network, long distance
  - b) Token Ring
  - c) FDDI
  - d) Ethernet
  - e) MD110
4. What requirements should be considered when planning an information network?
5. What is meant by “power budget”?
6. The power coupled into a fiber is 1.5 mW, and the attenuation of the fiber is 0.5 dB/km. Calculate the link’s maximum length if the receiver sensitivity is 2  $\mu$ W, assuming that there are no losses through connectors and splices.
7. The ratio of the input power to the output power in a 1 km long fiber is 2.5:1. Calculate the received power in a 5 km long fiber. The power coupled into the fiber from the transmitter is 1 mW and there are no splices or connectors.
8. Make up a power budget for a fiber link with the following components:
 

- Transmitter: 1.5 mW;	NA = 0.15;	diameter = 13 $\mu$ m
- Patch cord: Length = 20 m;	NA = 0.12;	fiber: 11/125 $\mu$ m
- 4 cables of 5 km each: 9.5/125 $\mu$ m fiber;	NA = 0.10;	att. = 0.20 dB/km (1550)
- 1 cable of 3 km: 10.5/125 $\mu$ m fiber;	NA = 0.12;	att. = 0.40 dB/km (1550)
- 4 cables of 5 km each: 9.5/125 $\mu$ m fiber;	NA = 0.10;	att. = 0.20 dB/km (1550)
- Connector losses:	0.5 dB/connector	
- Splice losses:	0.15 dB/splice	
- Patch cord: Length = 20 m;	NA = 0.12;	fiber: 11/125 $\mu$ m
- Receiver: Sensitivity 1 $\mu$ W;	NA = 0.25;	diameter = 30 $\mu$ m

*Will this optical fiber cable link function???*

9. What is the expected material dispersion for a 50 km long single-mode fiber link at 1550 nm if the transmitter bandwidth is 2 nm?
10. What optical bandwidth can be expected for the fiber link described in exercise 9?
11. How great will the mode dispersion be in a 1 km long 100/140  $\mu$ m fiber with refractive indices as follows:
 
$$n_{\text{core}} = 1.47 \quad n_{\text{cladding}} = 1.45$$



### **Fiberoptic measuring instruments and measurement in single-mode fiber networks**

1. Three different instruments are used for normal measurement in a fiberoptic installation. Which are these instruments?  
Describe how they are used.
2. What kinds of measurement can be made by means of an OTDR?
3. What is meant by the two-point method and the five-point method?
4. When should a optical fiber cable installation normally be tested?
5. What should be measured during testing?
6. What should be presented in the optical fiber measuring documentation called “final verification”?
7. Describe the process of fault tracing.

### **Installation of optical fiber cable**

1. When are cable ducts used?
2. What is meant by “subducts”?
3. When is it appropriate to use DMDPs (Distributed Mechanical Pulling Devices)?
4. Name some of the important details that must be considered when directly burying cable.
5. What is the size of the smallest bend radius that an optical fiber cable may be subjected to, and why does this limit exist?
6. What factors should be considered when plowing cable directly into the ground?
7. Name some of the more important things to consider when installing submarine cables.
8. What are the methods used for installing aerial optical fiber cable?
9. Describe how lashing of aerial optical fiber cable is done.
10. Describe how wrapping of aerial optical fiber cable is done.
11. What are the essential differences between indoor and outdoor cable. Why do these differences exist?
12. What are the requirements for a splice box for optical fiber cable?
13. When is a line terminal used?



## Chapter 15

# Index

### A

absorption ..... 6-14  
acceptance cone ..... 4-6  
acrylate ..... 3-10, 5-3  
aluminium, oxide ..... 5-25  
    trihydroxide ..... 5-25  
amplified spontaneous  
emission, ASE ..... 12-3  
amplifier, in-line ..... 12-12  
    power ..... 12-11  
    pre- ..... 12-13  
angle, critical ..... 4-12  
    of incidence ..... 2-3  
    of reflection ..... 2-3  
angular deviation ..... 8-9  
aramide yarn ..... 5-14, 5-30  
attenuation, ..... 10-5  
    measurement ..... 10-14  
    power loss ..... 10-5  
avalanche photodiode (APD) ..... 7-5

### B

Balmer series ..... 6-8  
band gap ..... 6-10  
bandwidth ..... 7-11, 9-13  
Bell, Alexander, G; ..... 1-3  
bessel function ..... 4-4  
bit error rate (BER) ..... 7-12  
Bohr, Niels ..... 6-6  
Bohr's model of... ..... 6-6  
brewster angle ..... 2-6  
buffer, ..... 5-5  
    fiber ribbon ..... 5-8  
    loose tube ..... 5-5  
    tight ..... 5-7  
bus ..... 9-2

### C

cable, aerial ..... 5-30, 11-13  
    direct buried ..... 11-3  
    direct ploughing ..... 5-28, 5-29  
    excess ..... 11-25  
    submarine ..... 11-17  
    trench ..... 11-5  
carbon-black ..... 5-24  
Chappe, Claude ..... 1-2

chromatic dispersion ..... 4-9  
cladding ..... 3-4, 4-2  
coherent ..... 6-15  
color-coded ..... 5-4  
conduction band ..... 6-9, 6-10, 6-16  
conductor ..... 6-10  
connector, expanded beam ..... 8-21  
    FC ..... 8-17  
    FC/PC ..... 8-17  
    FDDI ..... 8-20  
    LME ..... 8-16  
    MT ..... 8-21  
    SC ..... 8-18  
    SMA ..... 8-17  
    ST ..... 8-19  
consistent values ..... 13-1  
consolidation process ..... 3-3  
contraction of cable ..... 5-18  
core, fiber ..... 3-4, 4-2  
    circular ..... 5-15  
    slotted ..... 5-16  
    slotted - pitch ..... 5-17  
core/cladding non-concentricity ..... 8-6  
corrugated steel tape ..... 5-28  
cross phase modulation ..... 4-11  
cut-off wavelength ..... 4-4, 4-5

### D

dark current ..... 7-10  
dead zone ..... 10-6  
delivery testing ..... 10-12  
depletion region ..... 7-2  
deposition ..... 3-3, 3-6  
diffusion length ..... 7-2  
dispersion, ..... 4-8  
    chromatic ..... 4-9, 9-10  
    material ..... 4-9, 9-10  
    modal ..... 4-13, 9-13  
    shifted fibers ..... 4-15  
    waveguide ..... 4-9, 9-10  
    -compensating fiber ..... 4-18  
    -shifted fiber ..... 4-15  
distance measurement ..... 10-4  
doping ..... 3-1  
double-crucible ..... 12-6  
duct ..... 11-6  
dynamic range ..... 10-7

**E**

EDFA ..... 4-18  
 effective area ..... 4-7  
 electric field strength ..... 7-2  
 electromagnetic spectrum ..... 2-1  
 electromagnetism ..... 4-2  
 electron-hole pair ..... 6-11, 6-14, 7-1  
 encapsulating ..... 5-8  
 energy band diagram ..... 6-9  
 erbium, ..... 12-2  
   -doped fiber amplifier ..... 12-2  
 excitation ..... 6-13  
 excited, state ..... 6-14  
   state absorption ..... 12-1  
 expansion, of cable ..... 5-18  
   thermal ..... 5-19  
   window ..... 5-18

**F**

fault tracing ..... 10-14  
 Fermi level ..... 6-13  
 fiber, as a lens ..... 6-19  
   cleaving ..... 8-10  
   color-coding ..... 5-4  
   coupled to the detector ..... 7-8  
   distribution field ..... 11-28  
   drawing ..... 3-8  
   excess length ..... 5-17  
   multimode ..... 5-2  
   ribbon encapsulating ..... 5-8  
   singlemode ..... 5-2  
   to the curb ..... 11-18  
   to the desktop ..... 11-18  
   to the home ..... 1-8, 11-18  
   -related losses ..... 8-3  
 filling compound ..... 5-15, 5-22  
 final documentation ..... 10-16  
 five-point method ..... 10-5  
 fluorine ..... 3-1  
 fluoroplastic ..... 5-27  
 fluoroplastics ..... 5-27  
 focal length ..... 2-4  
 focus ..... 2-4  
 four-wave mixing ..... 4-11  
 French, Norman R.; ..... 1-4  
 Fresnel's laws of reflection ..... 2-6  
 FTTC ..... 11-18  
 FTTD ..... 11-18  
 FTTH ..... 11-18  
 full-duplex ..... 9-2  
 fusion process ..... 8-12  
 fusion splicing ..... 8-11

**G**

gain, ..... 12-4  
   bandwidth ..... 12-4  
 GASLCV ..... 5-30  
 geometrical optics ..... 2-2

germanium ..... 3-1, 3-4, 6-11  
 GNKKD ..... 5-21  
 GNSLCV ..... 13-4, 13-5  
 GNSLLDV ..... 5-29  
 GNSLSLDV ..... 5-30  
 GNSLTLV ..... 5-28, 5-29  
 graded index fiber ..... 4-13  
 group refractive index ..... 4-6  
 guy-grips ..... 11-14

**H**

half-duplex ..... 9-2  
 halogen-free, flame-retardant  
   materials ..... 5-24  
 heat expandable tape - HET ..... 5-29  
 hybrid cables ..... 5-31

**I**

i-layer ..... 7-4  
 IEC ..... 5-5  
 index profile ..... 4-1  
 indices of refraction ..... 2-4  
 inspection after laying ..... 10-13  
 insulator ..... 6-10  
 intermodal dispersion ..... 4-8  
 intramodal dispersion ..... 4-9  
 intrinsic layer ..... 7-4  
 IOR ..... 2-4  
 ITU ..... 5-5

**J**

junction area ..... 6-16

**K**

Kao, Charles H.; ..... 1-5

**L**

laser, ..... 6-17  
   diode ..... 6-3  
   distributed feedback ..... 6-19  
   Fabry Perot ..... 6-17  
   heterostructure ..... 6-18  
   output power ..... 6-24  
   spectral width ..... 6-25  
 lashing ..... 11-15  
 LED, (light emitting diode) ..... 6-21  
   Burrus ..... 6-23  
   dual heterojunction ..... 6-21  
   edge emitting ..... 6-23  
   efficiency of... ..... 6-24  
   output power ..... 6-24  
   spectral width ..... 6-25  
 lens ..... 2-4  
 letter code ..... 13-3  
 light, polarized ..... 2-5  
   TE-polarized ..... 2-6  
   TM-polarized ..... 2-6  
   visible ..... 2-1

lighthouses ..... 1-2  
 line terminal ..... 11-28  
 longitudinal separation ..... 8-8  
 loss, in a network ..... 9-5  
 lubricant ..... 11-7  
 Lyman series ..... 6-8

## M

maintenance test ..... 10-16  
 many-point method ..... 10-5  
 material dispersion ..... 4-9  
 Maxwell, James C.; ..... 4-2  
 Maxwell's equations ..... 4-2  
 MCVD method ..... 3-3  
 micro-bends ..... 5-3, 5-19  
 microlens ..... 6-20  
 mode, ..... 4-2  
   coupling ..... 4-3, 4-10  
   field diameter ..... 4-7  
   field difference ..... 8-4  
 modes, ..... 4-2  
   leaky ..... 4-6  
   LP01 ..... 4-4  
   number of... ..... 4-3  
 modified chemical vapor deposition ... 3-3  
 modulation ..... 6-26  
 molecular spectra ..... 6-8  
 MT ..... 11-28  
 MTRJ ..... 11-28  
 multimode fiber ..... 4-2, 4-12, 4-13

## N

n-doped ..... 6-12  
 noise, figure ..... 12-5  
 non-zero dispersion shifted fiber .. 4-16  
 nonlinear effect ..... 4-10  
 normalized frequency ..... 4-3  
 numerical aperture ..... 4-5, 4-6

## O

optical, access network ..... 11-18  
   distribution frame (ODF) ... 11-28  
   gain 6-17  
   ground wire ..... 5-31  
   window ..... 2-2  
 OTDR test ..... 10-14  
 outside vapor deposition (OVD) .... 3-6

## P

p-doped ..... 6-12  
 p-material ..... 6-12  
 p-n junction ..... 6-15  
 Peltier element ..... 6-20  
 phonon ..... 12-3  
 photodiode ..... 7-1  
 photodiode, APD-type ..... 7-5  
 photodiode, p-n type ..... 7-1  
 photodiode, pin-type ..... 7-3

photomultiplication ..... 7-5  
 photon ..... 6-14  
 photophone ..... 1-3  
 pinpointing the fault ..... 10-15  
 plowing ..... 11-3  
 point-to-point ..... 9-2  
 polarization mode dispersion 4-9, 4-10  
 polarized light ..... 2-5  
 polyamide, (PA, nylon) ..... 5-26  
 polybutylene terephthalate ..... 5-27  
 polyethylene, ..... 5-24  
   low density ..... 5-24  
   low linear density ..... 5-24  
 polyurethane ..... 5-27  
 polyvinyl chloride, (PVC) ..... 5-25  
 power, budget ..... 9-5  
   meter ..... 10-9  
 precision-drilled tubes ..... 8-14  
 preform, ..... 3-4  
   collapse ..... 3-5  
 primary coating ..... 3-10, 5-3  
 process testing ..... 5-9  
   attenuation ..... 5-12  
   fiber curl ..... 5-12  
   strippability ..... 5-11  
 profile index ..... 4-2  
 proof test ..... 3-10  
 pulse, broadening ..... 9-10  
   width ..... 10-6  
 pumping ..... 6-13

## Q

quantum, efficiency ..... 7-7  
   noise ..... 7-10  
 quartz, ..... 3-1  
   mineral sand ..... 3-1

## R

radial misalignment ..... 8-7  
 radiation lobe ..... 6-25  
 Rayleigh scattering ..... 2-7, 2-8  
 receiver ..... 9-5  
 recombination ..... 6-15, 7-1  
 reflectance ..... 2-6  
 reflection, ..... 2-3  
   law of.. ..... 2-3  
   total ..... 2-5, 2-7  
 refraction ..... 2-3  
 refractive, index ..... 2-4, 4-1, 13-2  
   group index ..... 4-6  
   index profile ..... 4-1  
 repeater ..... 12-1  
 responsivity ..... 7-8  
 ring network ..... 9-2  
 rod-in-tube ..... 12-6  
 Rydberg, Jan ..... 6-7

## S

saturation mode .....	12-4
self phase modulation .....	4-11
semiconductor .....	6-11
sheath .....	5-23
shot noise .....	7-10
signal-to-noise ratio (SNR) .....	7-11
silicon, .....	5-4, 6-11
atom, structure of... .....	6-12
dioxide .....	3-1
tetrachloride .....	3-2
simplex .....	9-2
single-mode fiber .....	4-2, 4-14
singlemode fiber .....	4-2, 4-4
sintering .....	3-6
slow tail response .....	7-3
Snell's law of refraction .....	2-3
solution doping .....	12-7
splice, box .....	11-26
splice, loss measurement .	10-5, 10-13
loss value .....	10-6
splicing, .....	11-24
environment .....	11-24
spontaneous emission .....	6-14
star .....	9-2
steel, band .....	5-29
tape .....	5-29
stimulated, brillouin scattering .....	4-11
emission .....	6-15, 6-16,
.....	6-17, 12-2
raman scattering .....	4-11
stratified-melt .....	12-6
strength member .....	5-14
strength member,	
central non-metallic .....	5-14
strength member, metallic .....	5-14
subduct .....	11-6
surface finish .....	8-10
suspension strand .....	5-30
swivel .....	11-8

## T

tapering .....	6-20
telegraph, electrical .....	1-3
optical .....	1-2
tensile, strength .....	5-4
stress .....	5-19
test, delivery .....	10-12
thermal, expansion .....	5-6
expansion coefficient .....	13-1
noise .....	7-9
thixotropic gel .....	5-6
three-rod splice .....	8-14
total, reflection .....	2-5
reflection in a fiber .....	2-7
towing eyelet .....	11-8
transmitter .....	9-4
tree .....	9-2

trench .....	11-5
two-point method .....	10-5
Tyndall .....	1-3
Tyndall light .....	2-7
type, testing .....	5-9
compatibility .....	5-11
macrobend .....	5-10
reliability .....	5-11
torsion .....	5-10

## V

v-block splice .....	8-14
VAD method .....	3-7
valence, band .....	6-9, 6-10, 6-16
electrons .....	6-11
vapor phase doping .....	12-7
vapor-phase axial deposition .....	3-7
warning tape .....	11-6
water-jet .....	11-17
waveguide dispersion .....	4-9
vertex, .....	8-9
misalignment .....	8-9
winch .....	11-8, 11-9
visible light .....	2-1
wrapping .....	11-15

## Y

Young's modulus .....	5-19, 13-1
-----------------------	------------

Note!  
Any comments or corrections regarding  
the content of this book are welcome  
to the author by e-mail:  
[stefan.gistvik@telia.com](mailto:stefan.gistvik@telia.com)

**Gistvik Communication**

SE-824 43 Hudiksvall

Sweden

Phone : +46 650 140 11

[stefan.gistvik@telia.com](mailto:stefan.gistvik@telia.com)